

# 0696E4PT

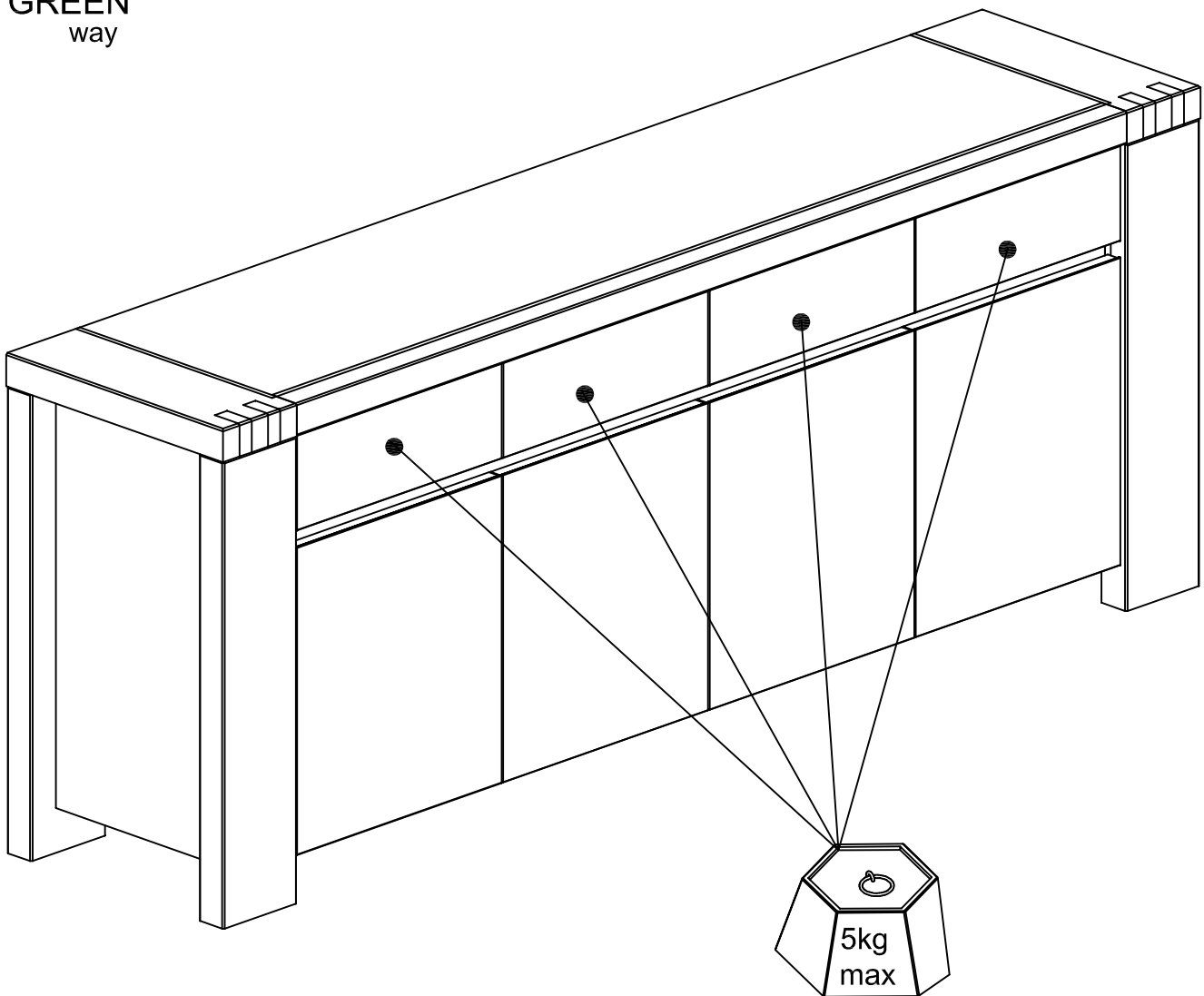

## FR Remerciements :

Nous vous remercions d'avoir choisi un meuble créé et fabriqué par le Groupe Parisot et espérons qu'il vous donnera entière satisfaction

## EN Thanks:

Thank you for choosing furniture designed and manufactured by the Parisot Group. We hope you are totally satisfied with your purchase

## DE Danksagung:

Wir danken Ihnen für den Kauf eines Frankreich von der Parisot-Gruppe entworfenen und hergestellten Möbelstücks und hoffen, dass Sie es zu Ihrer vollkommenen Zufriedenheit finden werden

## ES Agradecimientos:

Les damos las gracias por haber elegido un mueble diseñado y fabricado por el Groupe Parisot y esperamos que sea de su total agrado.

## PT Agradecimentos:

Obrigado por ter escolhido um móvel concebido e fabricado pelo Grupo Parisot, esperando que seja do seu inteiro agrado.

## IT Ringraziamenti:

Grazie per avere scelto un mobile progettato e fabbricato dal Gruppo Parisot. Speriamo soddisfatti appieno le vostre esigenze.

## NL Bedankje:

Wij bedanken u voor de aankoop van een door de Groep Parisot ontworpen en vervaardigd meubel en hopen dat u er veel plezier aan zult beleven.

## RU Благодарность:

Мы благодарим вас за то, что вы выбрали мебель, созданную и произведенную Групп Паризо, и надеемся, что вы будете полностью удовлетворены нашей продукцией.

## PL Podziękowania:

Dziękujemy za wybór mebli stworzonych i wyprodukowanych przez Grupę Parisot. Mamy nadzieję że będziecie Państwo w pełni zadowoleni z zakupu.

## SK Poďakovanie:

Ďakujeme, že ste si vybrali nábytok navrhnutý a vyrobený spoločnosťou Parisot Group. Dúfame, že budete svojím nákupom absolútne spokojní.

## CS Poděkování:

Děkujeme, že jste si vybrali nábytek navržený a vyrobený společností Parisot Group. Doufáme, že budete svým nákupem naprosto spokojeni.

## HU Köszönet:

Köszönjük, hogy a Parisot Groupe által létrehozott és gyártott bútort választott, reméljük, hogy elégedett lesz a termékkel.

## RO Mulțumiri:

Vă mulțumim că ați ales un articol de mobilier conceput și fabricat de Grupul Parisot și sperăm că veți fi pe deplin satisfăcuți de acesta.

## TR Teşekkür ederiz:

Parisot Group tarafından tasarlanan ve üretilen bu mobilyayı seçtiğiniz için teşekkür ederiz. Ürünümüzden memnun kalmanızı ümit ederiz.

## AR شكر:

باريزو نشكركم لاختياركم هذه القطعة من الأثاث من تصميم وبتصنيع مجموعة Parisot ونتمنى أن تتال رضاءكم.

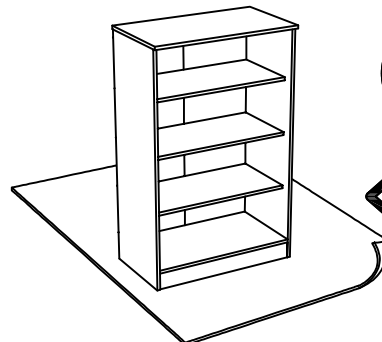
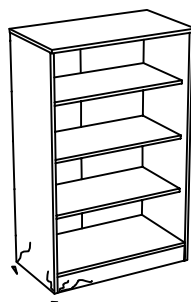
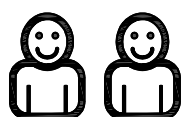
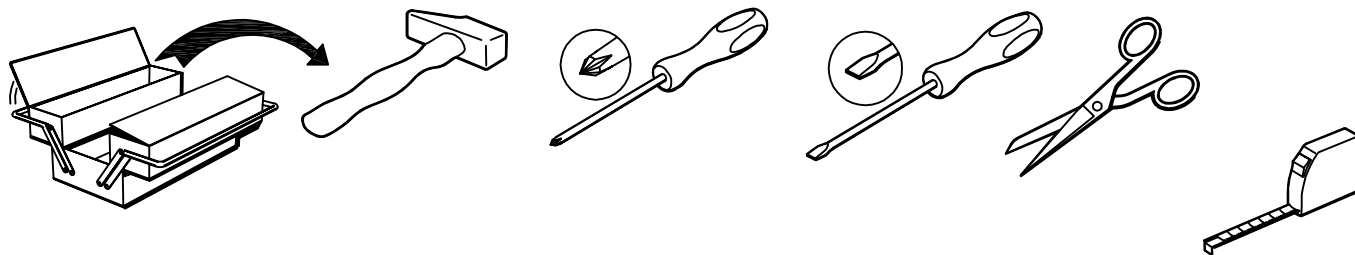

contact@parisot.com

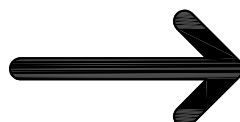
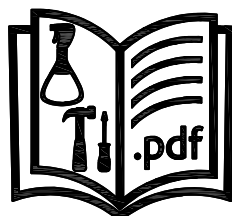

www.parisot.com

87 cm  
34 <sup>4</sup>/<sub>16</sub>"  
225,3 cm  
88 <sup>1</sup>/<sub>16</sub>"  
50 cm  
19 <sup>1</sup>/<sub>16</sub>"

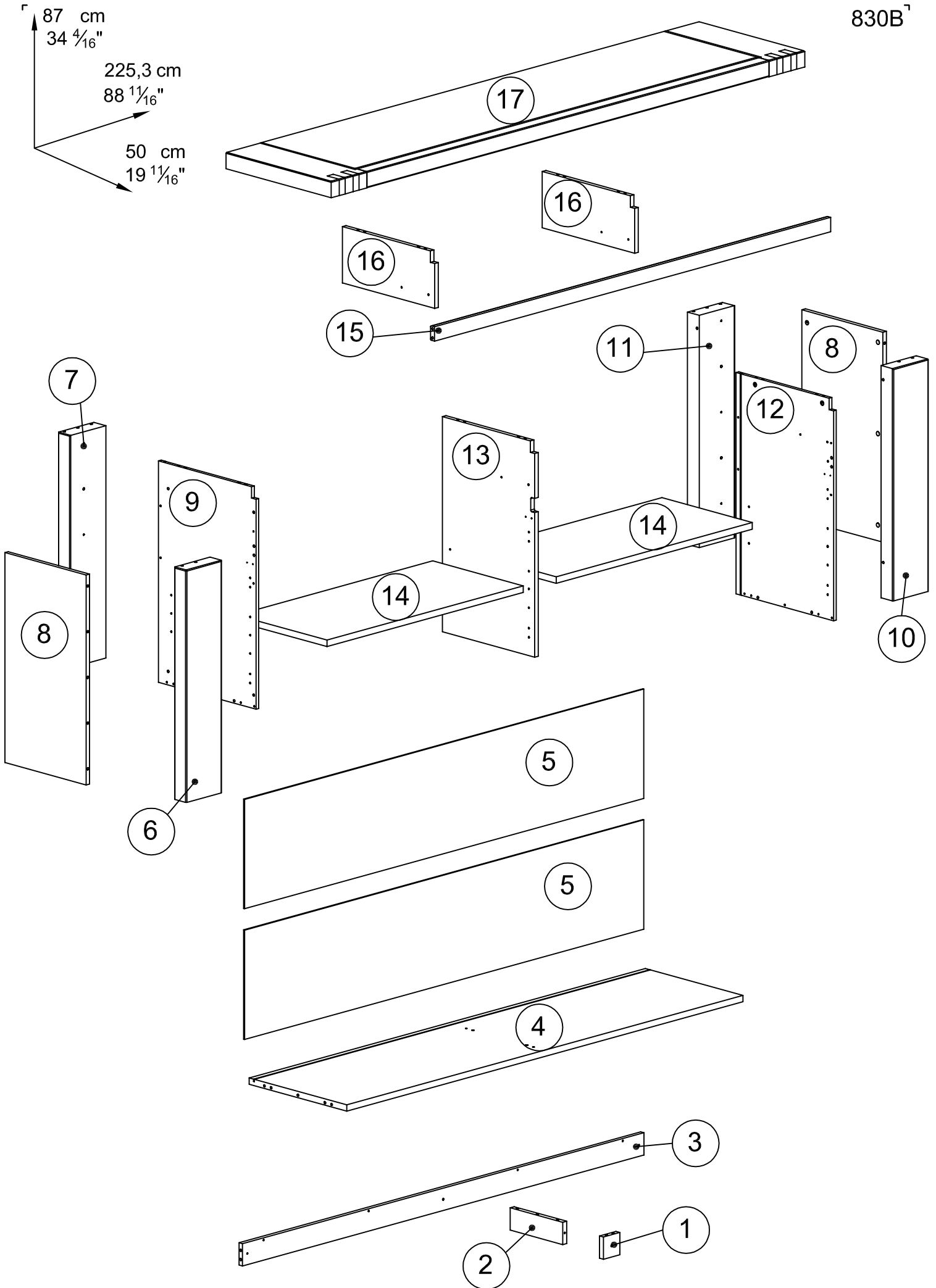

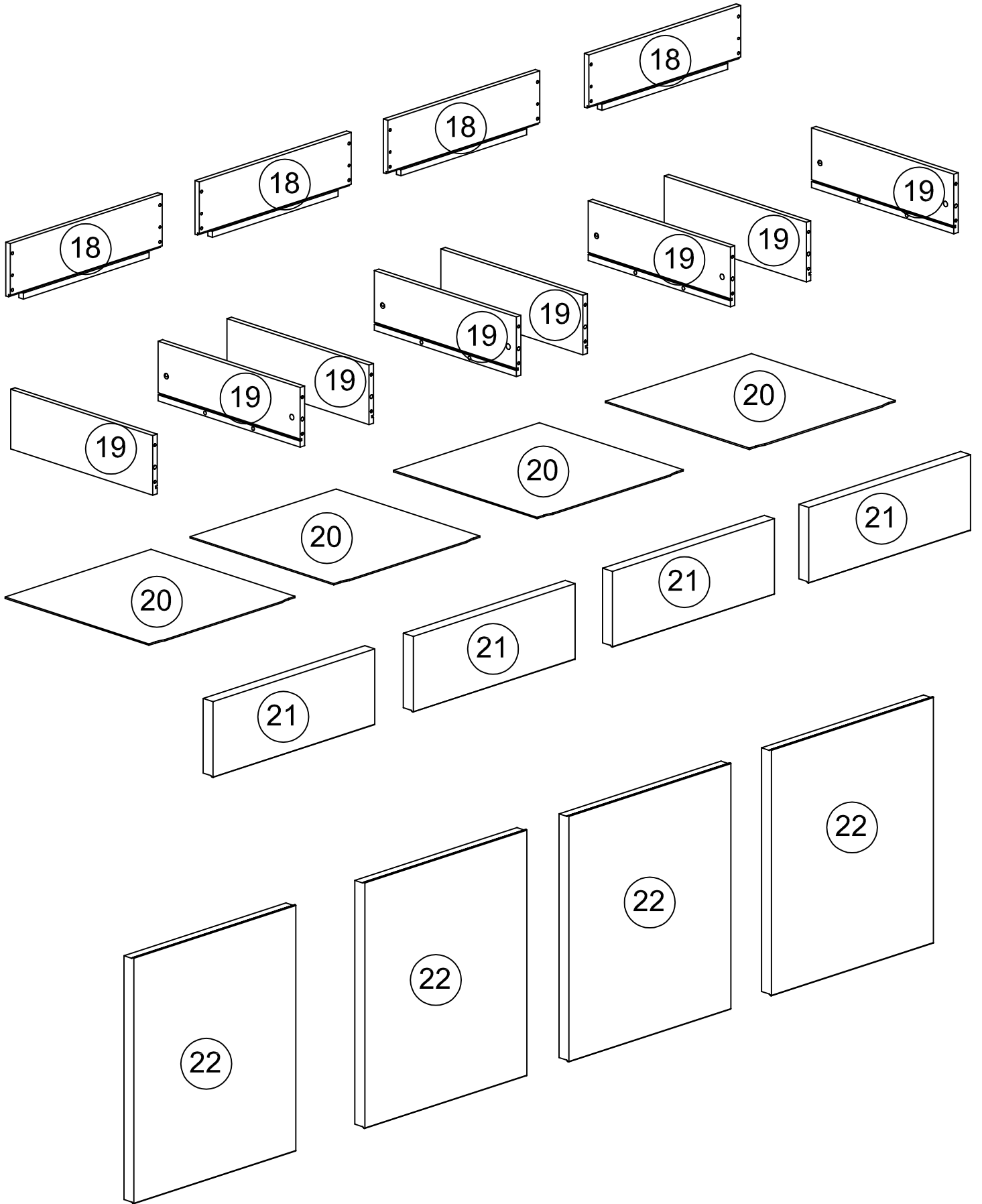

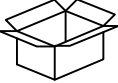
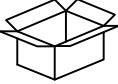
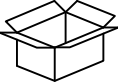
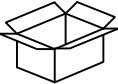
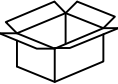
0696E4PT		mm			inch				
 0696E41Z	21	x	4	471,5	165	29	18 $\frac{9}{16}$ "	6 $\frac{8}{16}$ "	1 $\frac{2}{16}$ "
	22	x	4	536	472	29	21 $\frac{2}{16}$ "	18 $\frac{9}{16}$ "	1 $\frac{2}{16}$ "
	6	x	1	813	170	57	32"	6 $\frac{1}{16}$ "	2 $\frac{4}{16}$ "
	10	x	1	813	170	57	32"	6 $\frac{1}{16}$ "	2 $\frac{4}{16}$ "
 0696E42Z	8	x	2	735	385	16	28 $\frac{15}{16}$ "	15 $\frac{3}{16}$ "	$\frac{10}{16}$ "
	9	x	1	775	464	13	30 $\frac{8}{16}$ "	18 $\frac{4}{16}$ "	$\frac{8}{16}$ "
	12	x	1	775	464	13	30 $\frac{8}{16}$ "	18 $\frac{4}{16}$ "	$\frac{8}{16}$ "
	7	x	1	813	170	57	32"	6 $\frac{1}{16}$ "	2 $\frac{4}{16}$ "
	11	x	1	813	170	57	32"	6 $\frac{1}{16}$ "	2 $\frac{4}{16}$ "
 0696E43Z	17	x	1	2253	500	57	88 $\frac{1}{16}$ "	19 $\frac{1}{16}$ "	2 $\frac{4}{16}$ "
 0696E44Z	19	x	8	414	130	13	16 $\frac{5}{16}$ "	5 $\frac{2}{16}$ "	$\frac{8}{16}$ "
	20	x	4	423	425.5	3	16 $\frac{10}{16}$ "	16 $\frac{12}{16}$ "	$\frac{2}{16}$ "
	18	x	4	442.5	130	13	17 $\frac{7}{16}$ "	5 $\frac{2}{16}$ "	$\frac{8}{16}$ "
	16	x	2	439.5	197	17	17 $\frac{5}{16}$ "	7 $\frac{12}{16}$ "	$\frac{11}{16}$ "
	13	x	1	753	439.5	17	29 $\frac{10}{16}$ "	17 $\frac{5}{16}$ "	$\frac{11}{16}$ "
	14	x	2	933	430	23	36 $\frac{12}{16}$ "	16 $\frac{15}{16}$ "	$\frac{14}{16}$ "
 0696E45Z	1	x	1	78	78	19	3 $\frac{1}{16}$ "	3 $\frac{1}{16}$ "	$\frac{12}{16}$ "
	2	x	1	250	78	19	9 $\frac{13}{16}$ "	3 $\frac{1}{16}$ "	$\frac{12}{16}$ "
	15	x	1	1885	50	19	74 $\frac{3}{16}$ "	1 $\frac{15}{16}$ "	$\frac{12}{16}$ "
	4	x	1	1885	464	22	74 $\frac{3}{16}$ "	18 $\frac{4}{16}$ "	$\frac{14}{16}$ "
	5	x	2	1899	383	3	74 $\frac{12}{16}$ "	15 $\frac{1}{16}$ "	$\frac{2}{16}$ "
	3	x	1	1911	77	16	75 $\frac{4}{16}$ "	3 $\frac{1}{16}$ "	$\frac{10}{16}$ "

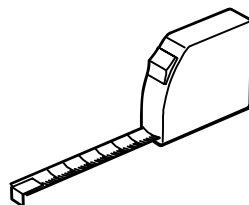

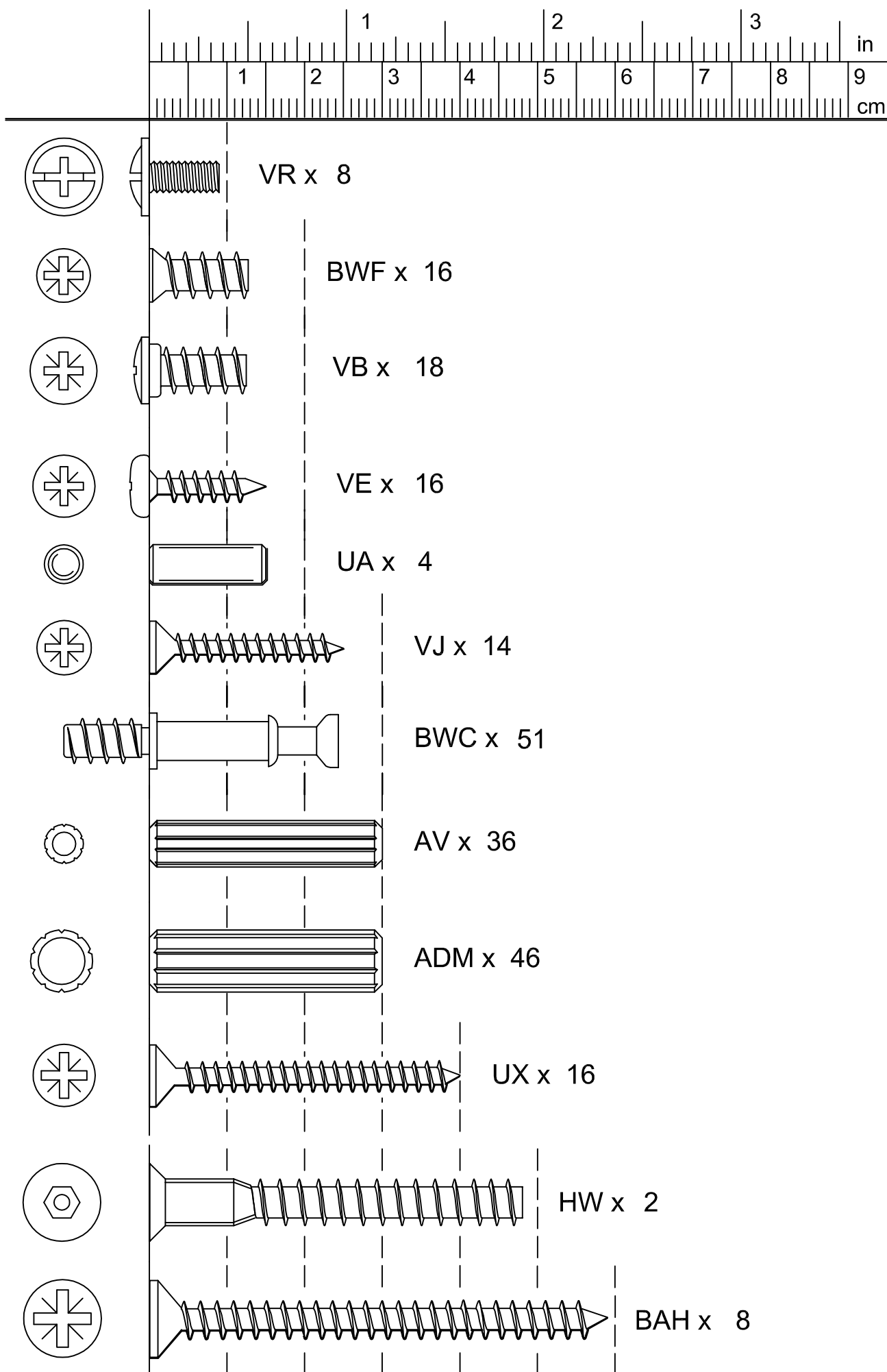

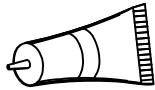

CF x 2



ZBJ x20



Ai x 31

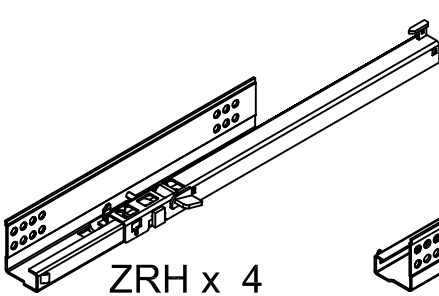

ZRH x 4

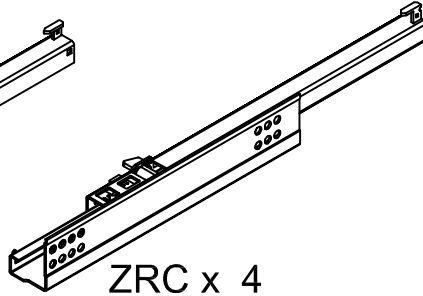

ZRC x 4

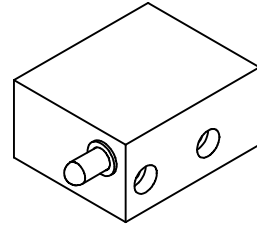

ZSS x 4



HV x 1

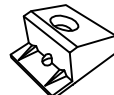

EP x 12

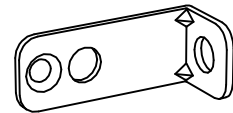

BLL x 11

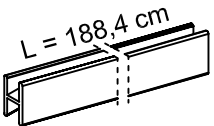

ZPO x 1

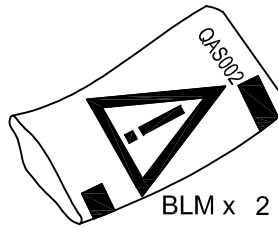

BLM x 2



BWD x 8

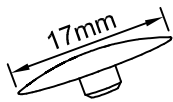

ZLR x 4

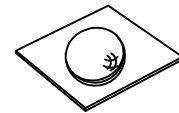

AQO x 8

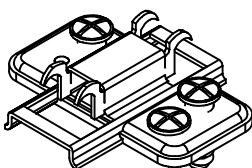

BYS x 8

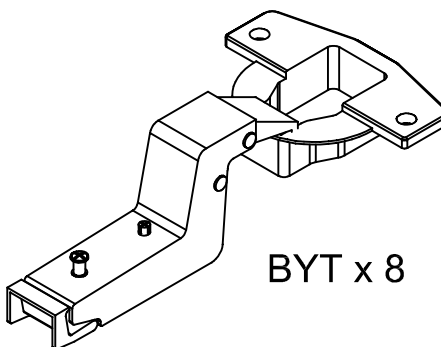

BYT x 8





3



Ai x 6

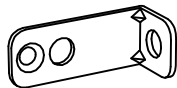

BLL x 1



UX x 1

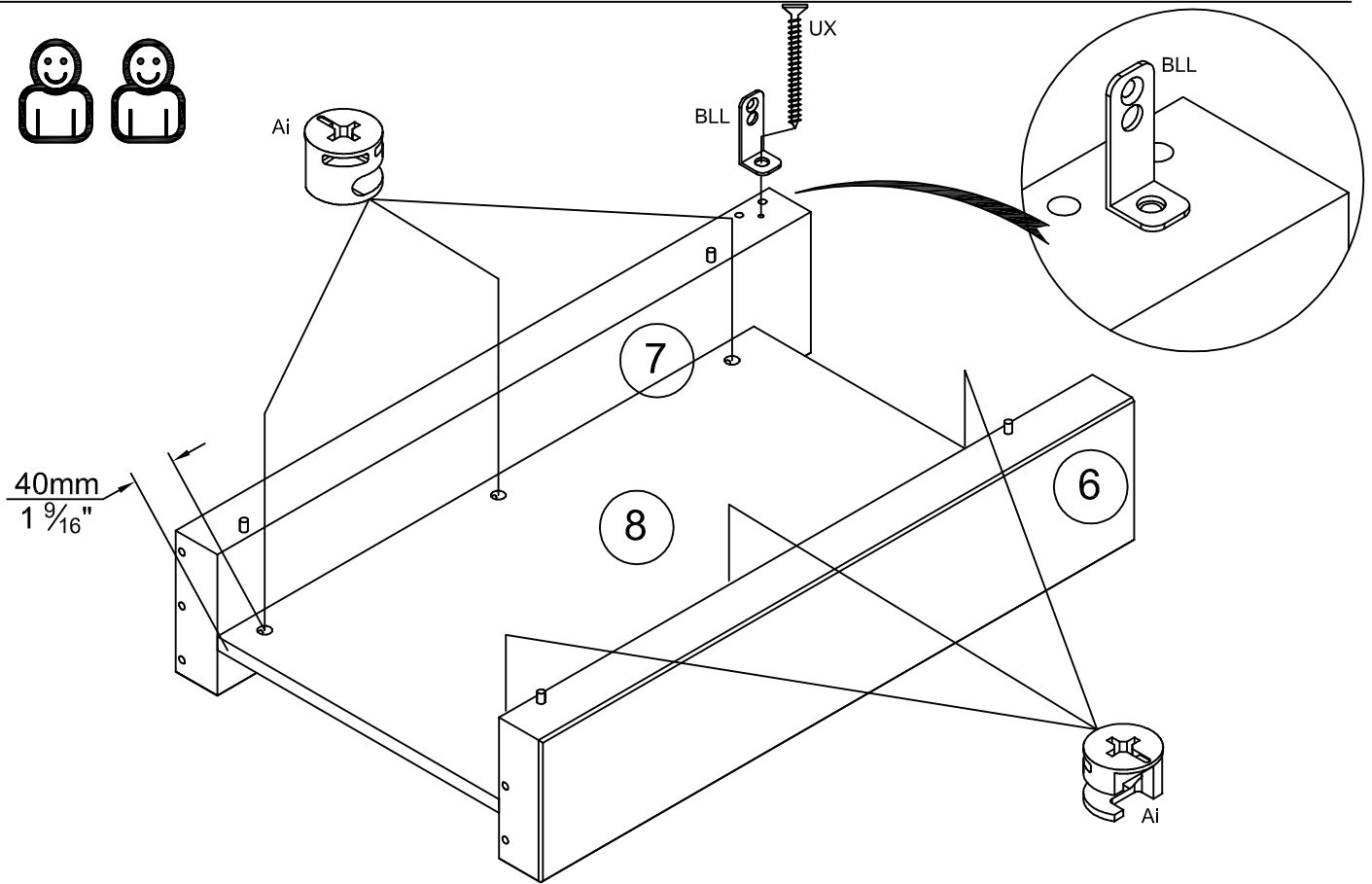
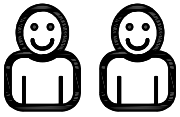

4



BWF x 2

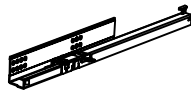

ZRC x 1

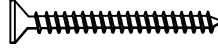

UX x 6

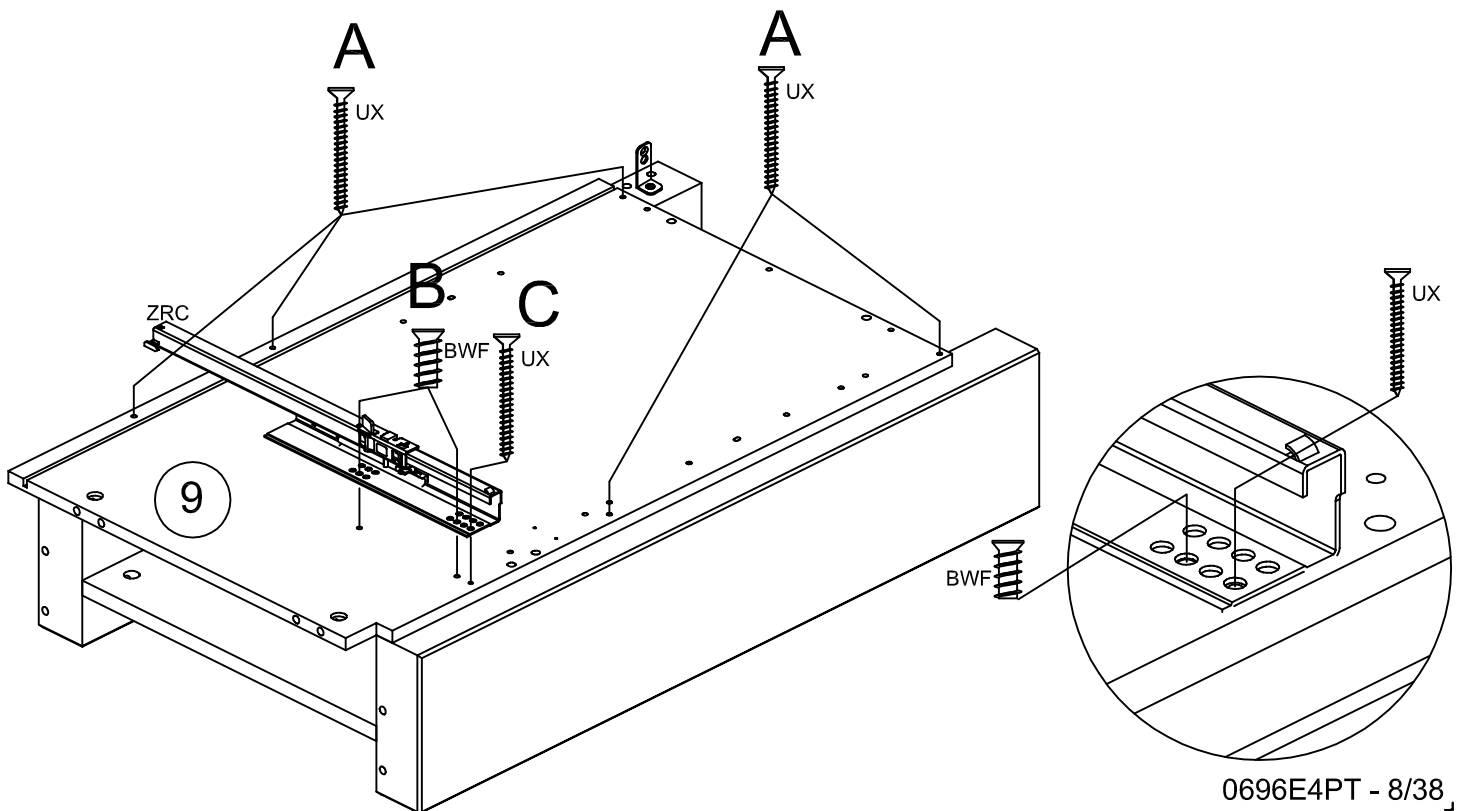

**5**

BYS x 2    ADM x 3    AV x 2

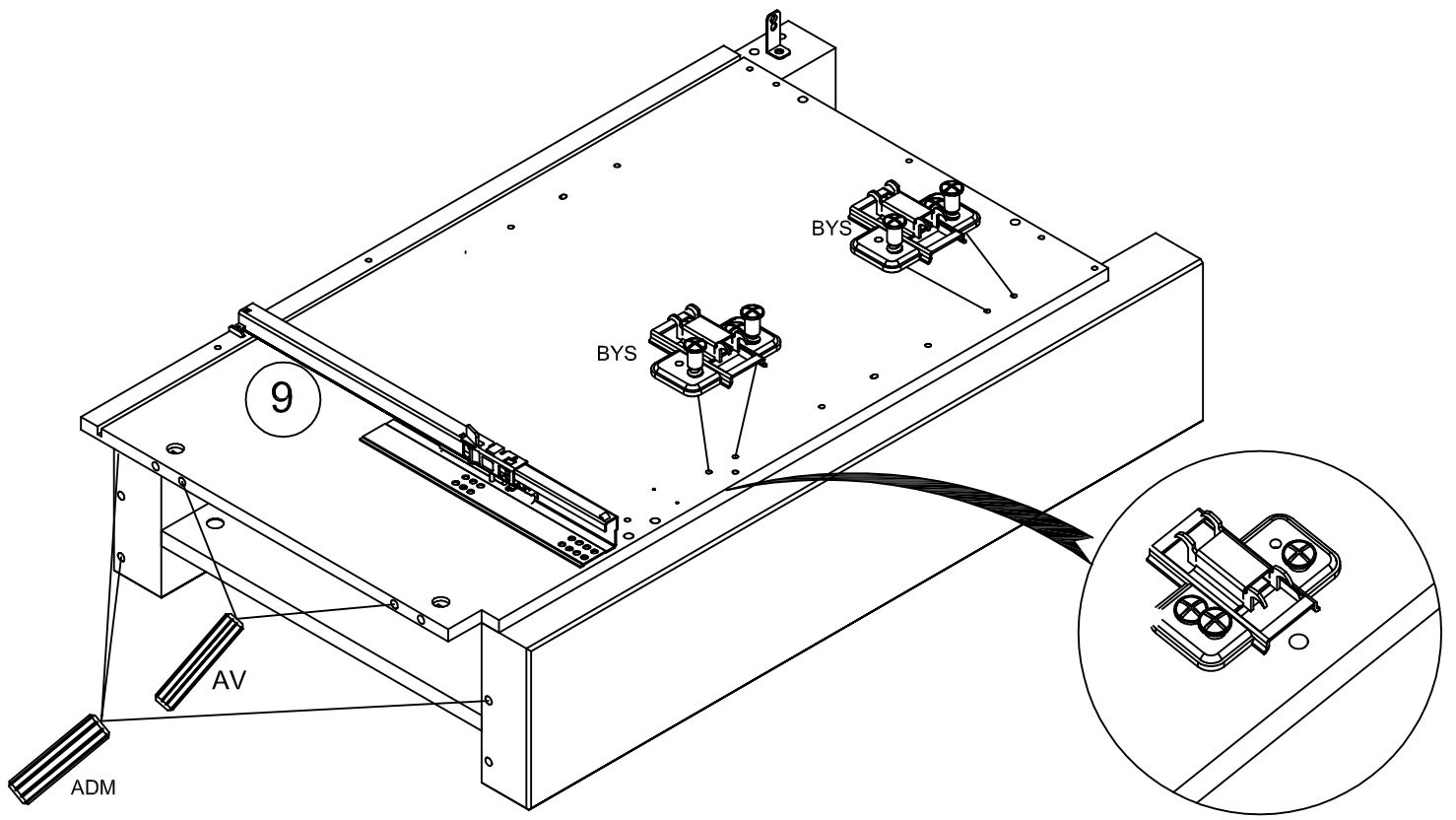

**6**

BWD x 2    BWC x 3

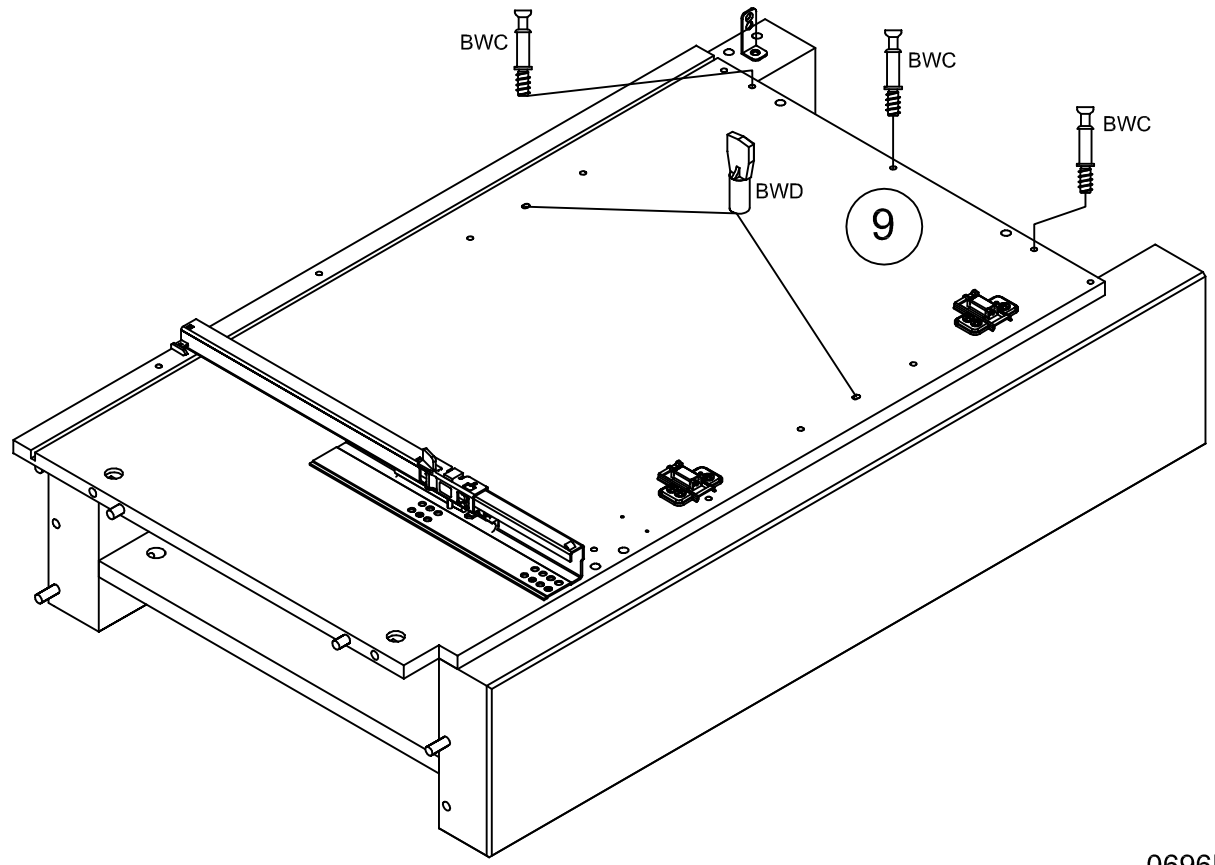
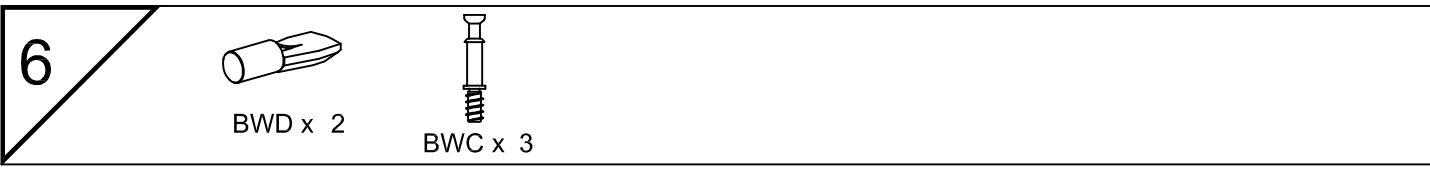

7

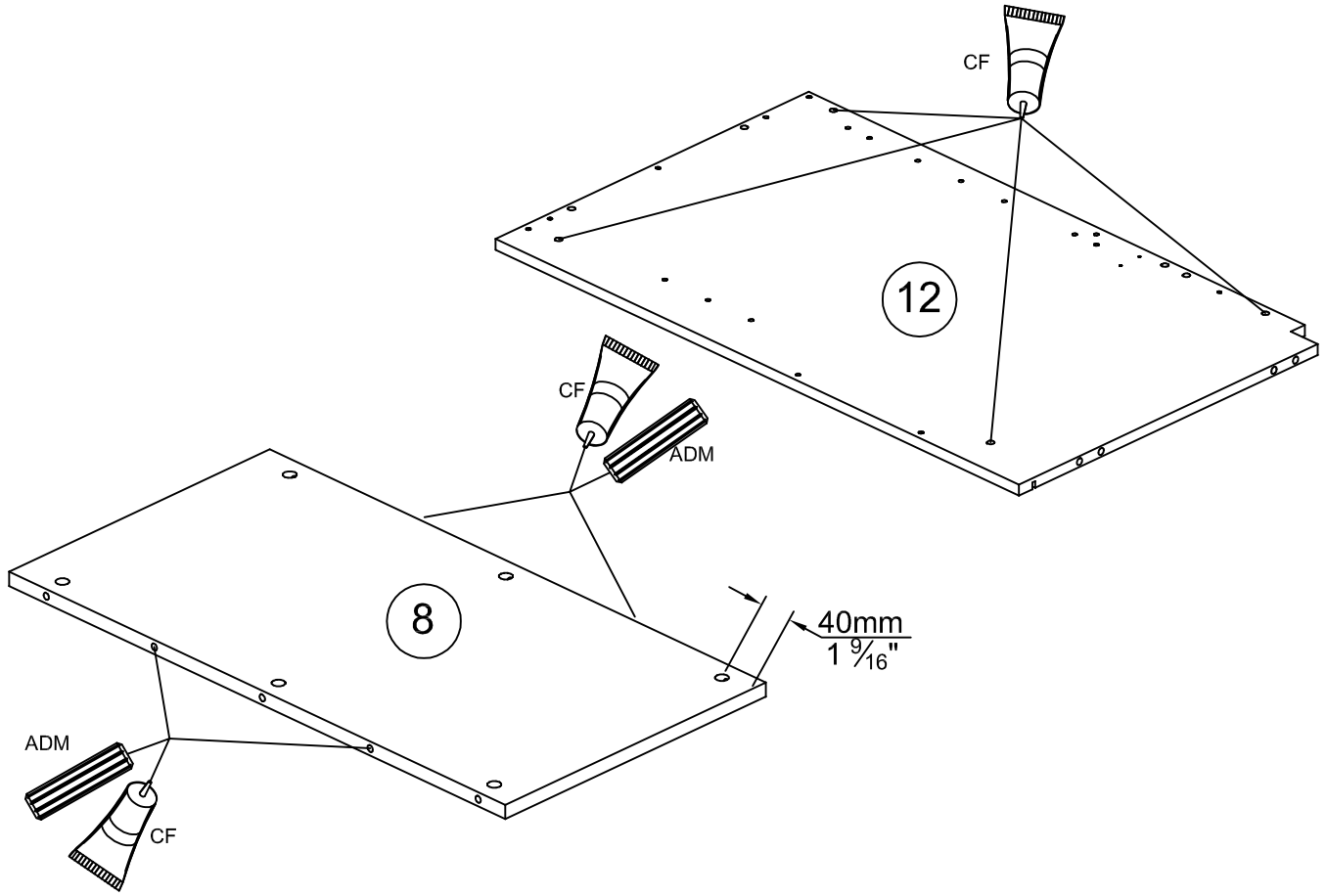
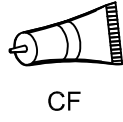

8

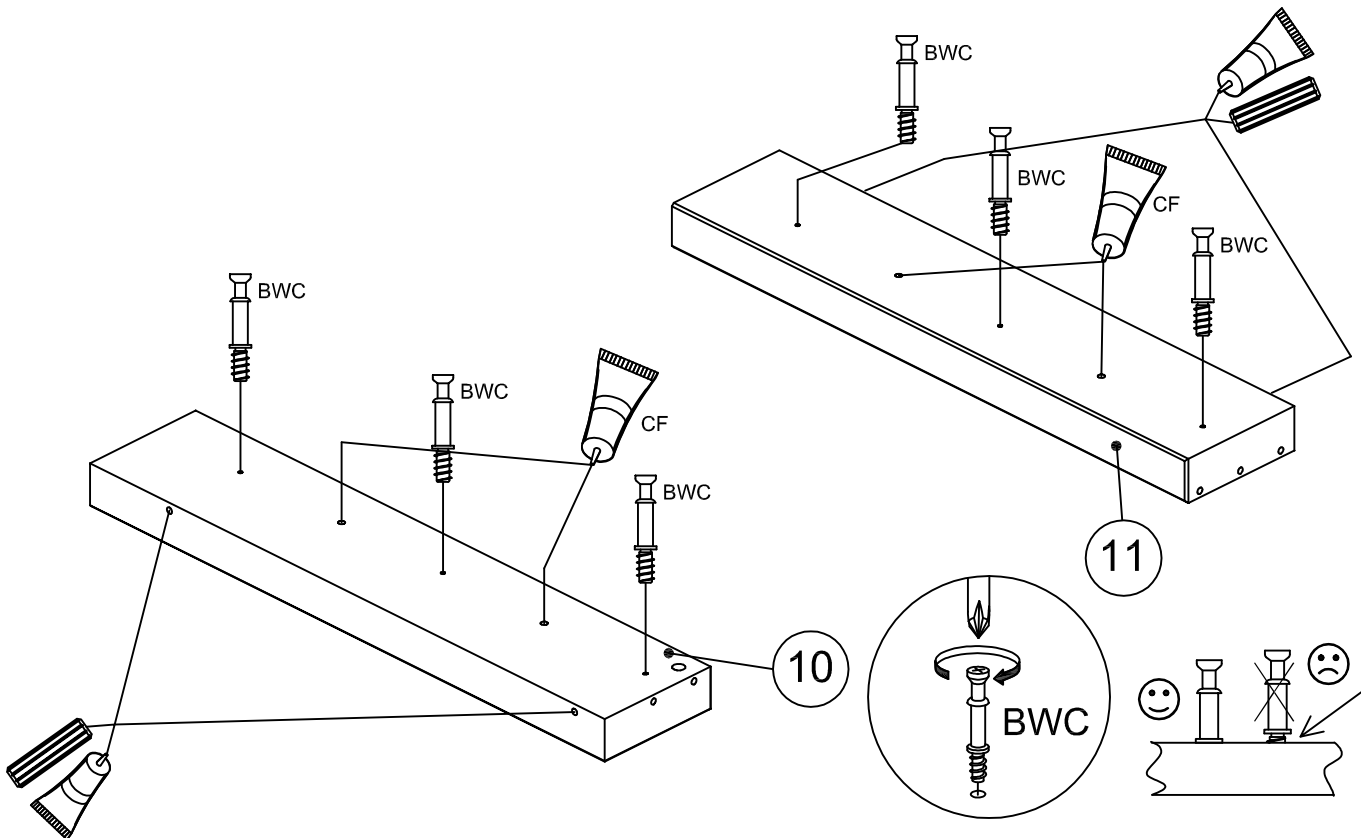
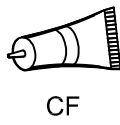
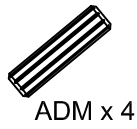
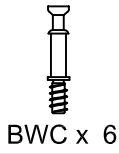

9



Ai x 6

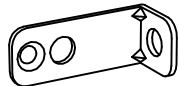

BLL x 1



UX x 1

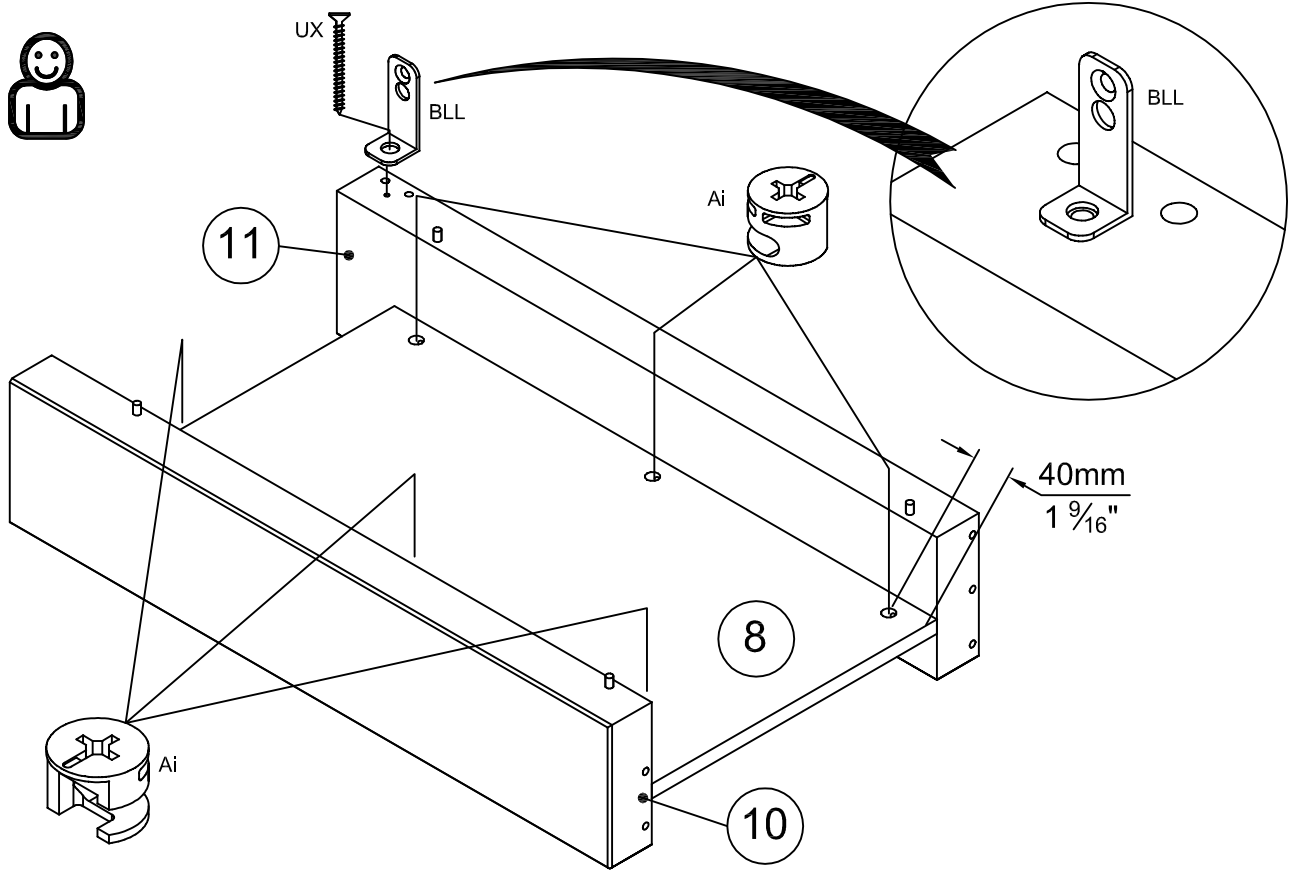

10



BWF x 2

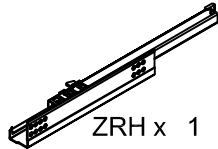

ZRH x 1

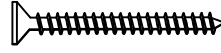

UX x 6

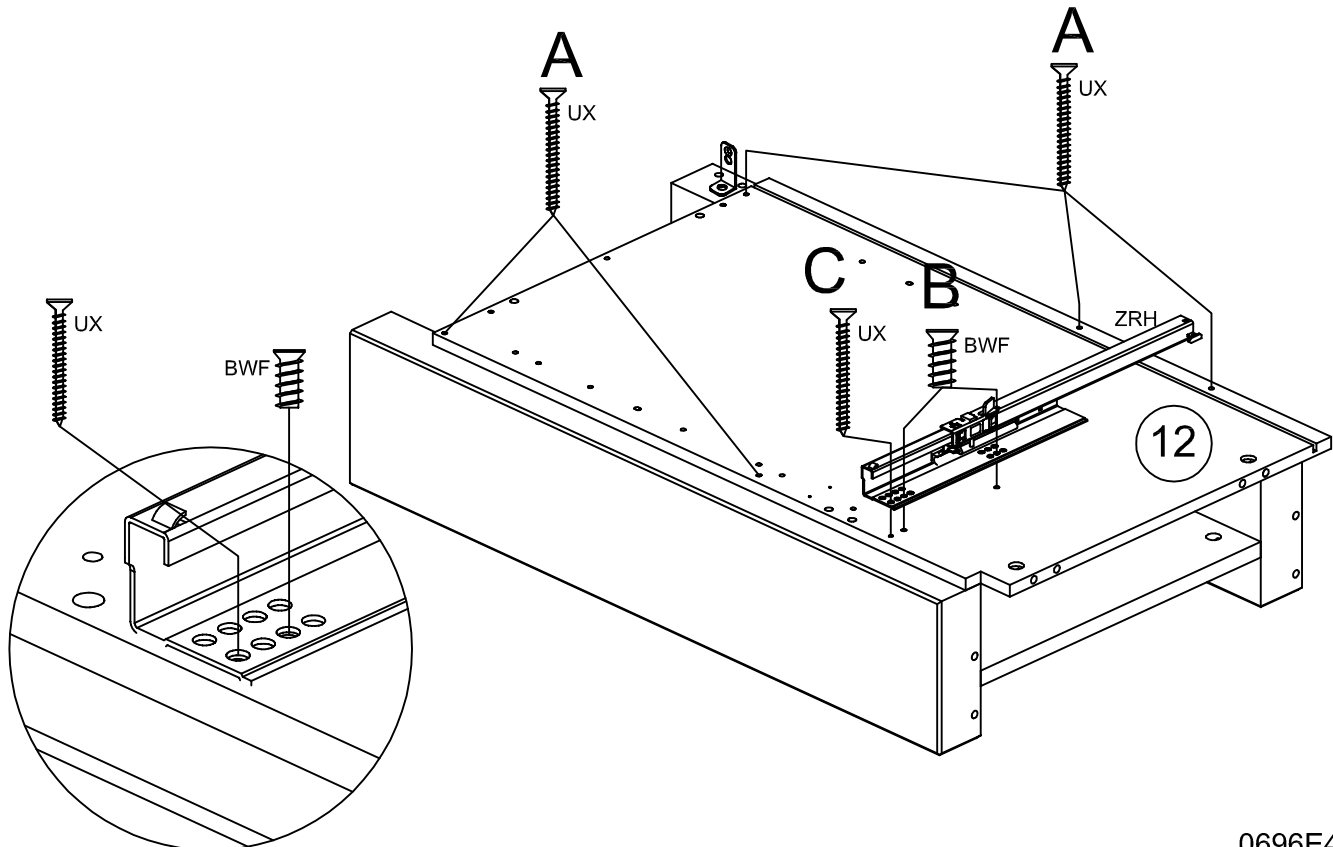

11

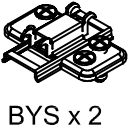

BY5 x 2



ADM x 3



AV x 2

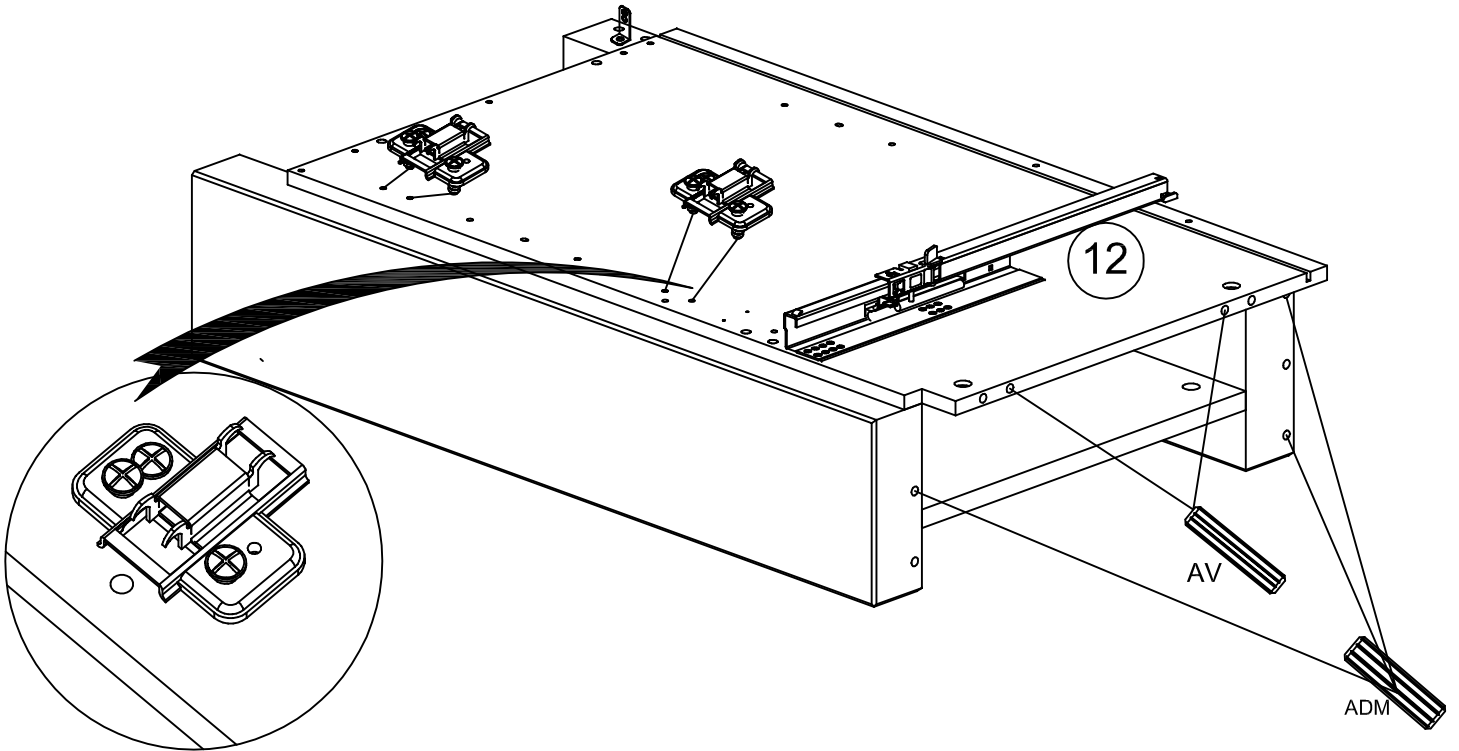

12



BWD x 2

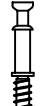

BWC x 3

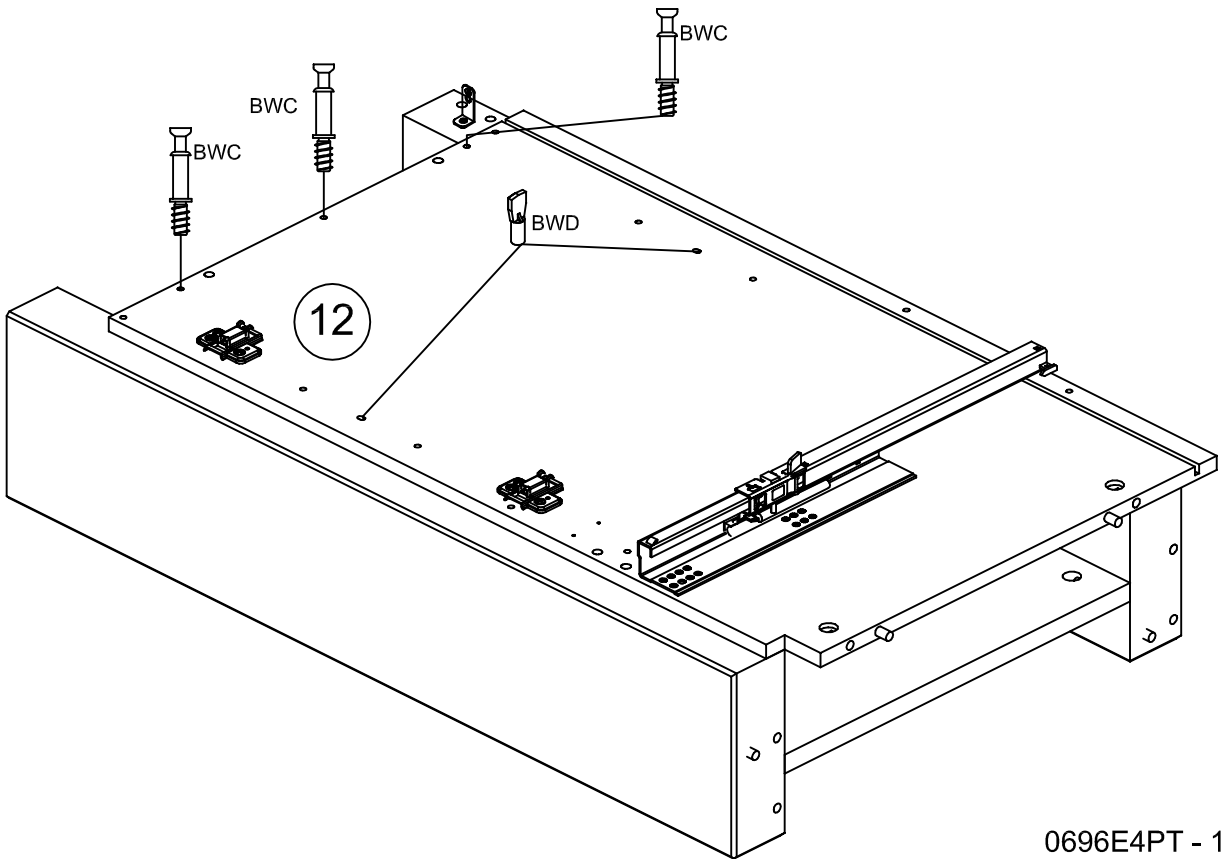

13



VB x 4



BLL x 4



ADM x 4

830B

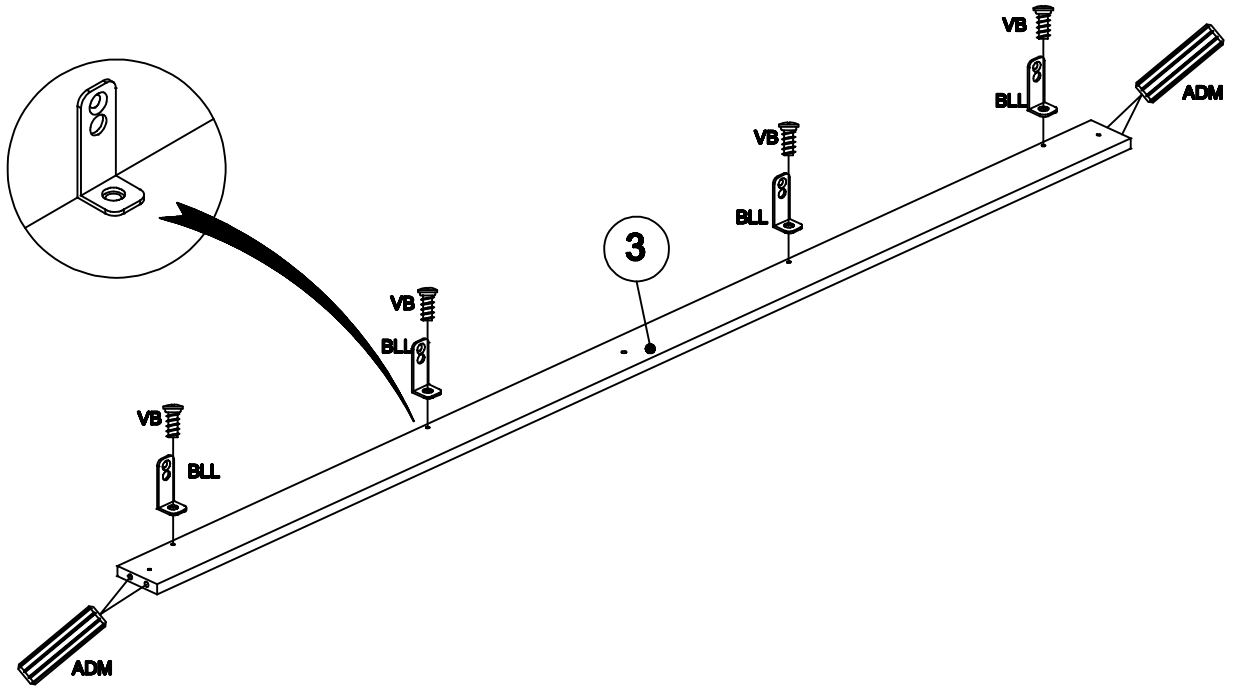

14



ADM x 4



CF

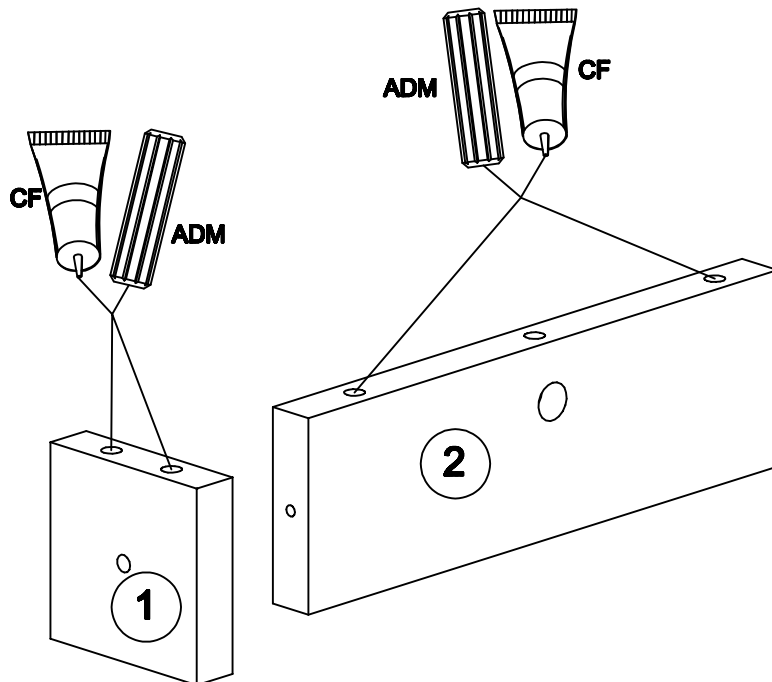

15

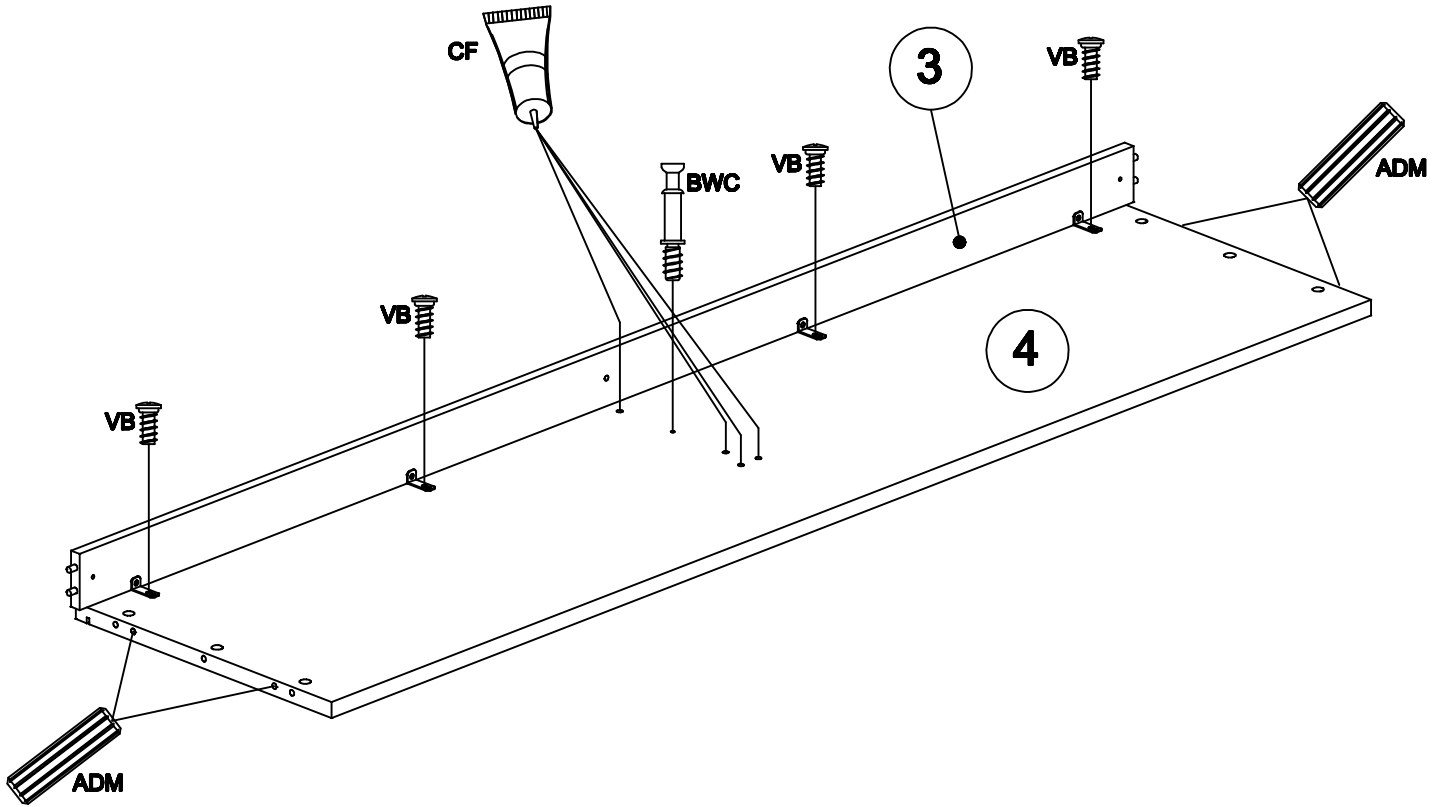
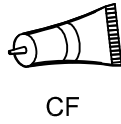
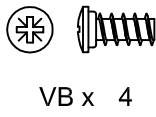
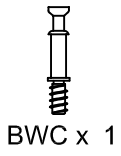

16

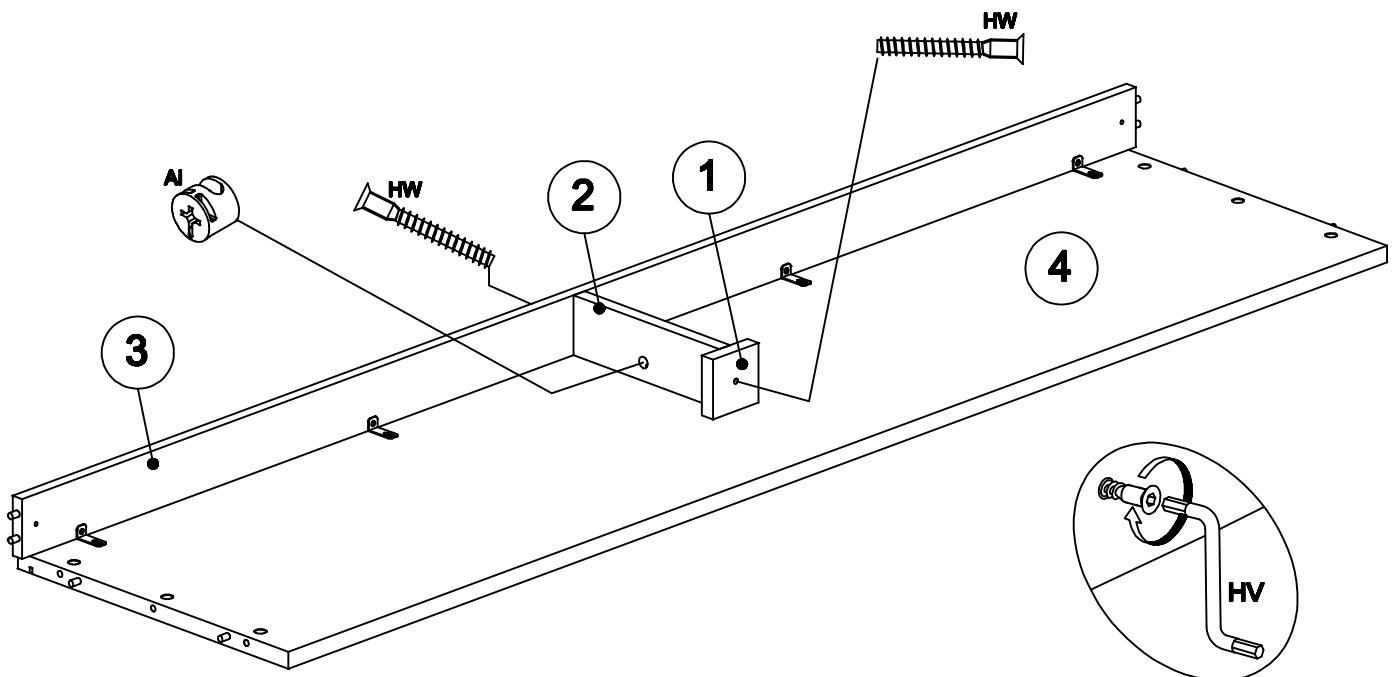
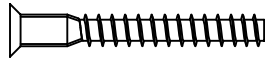

17



Ai x 3

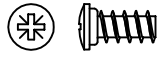

VB x 1

830B

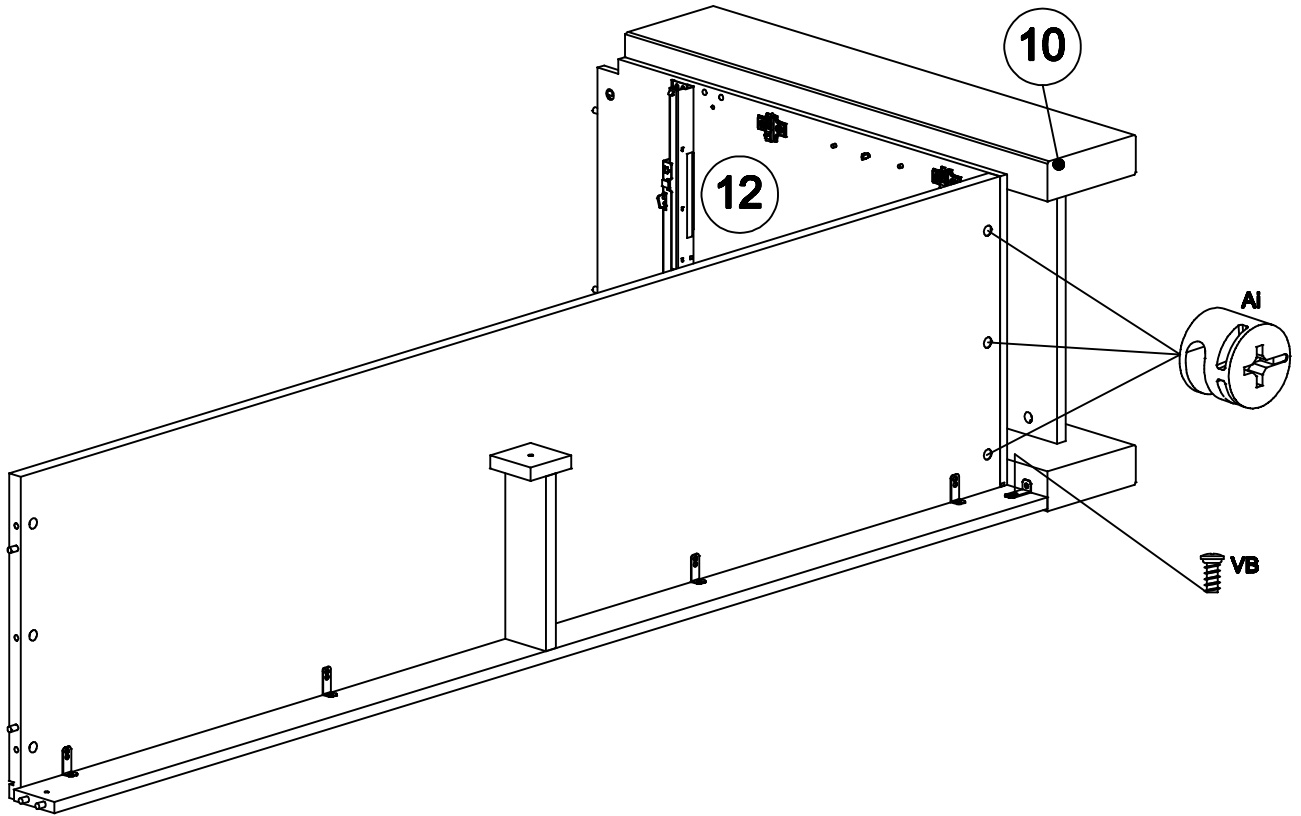

18



BWC x 2

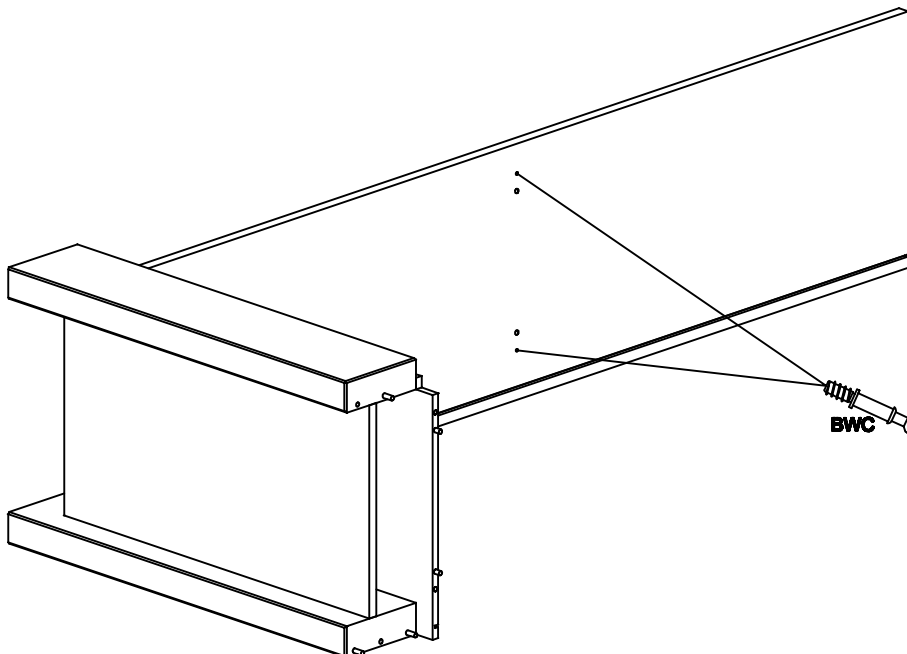



19



BWF x 2



ADM x 4

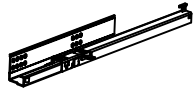

ZRC x 1

830B<sup>7</sup>

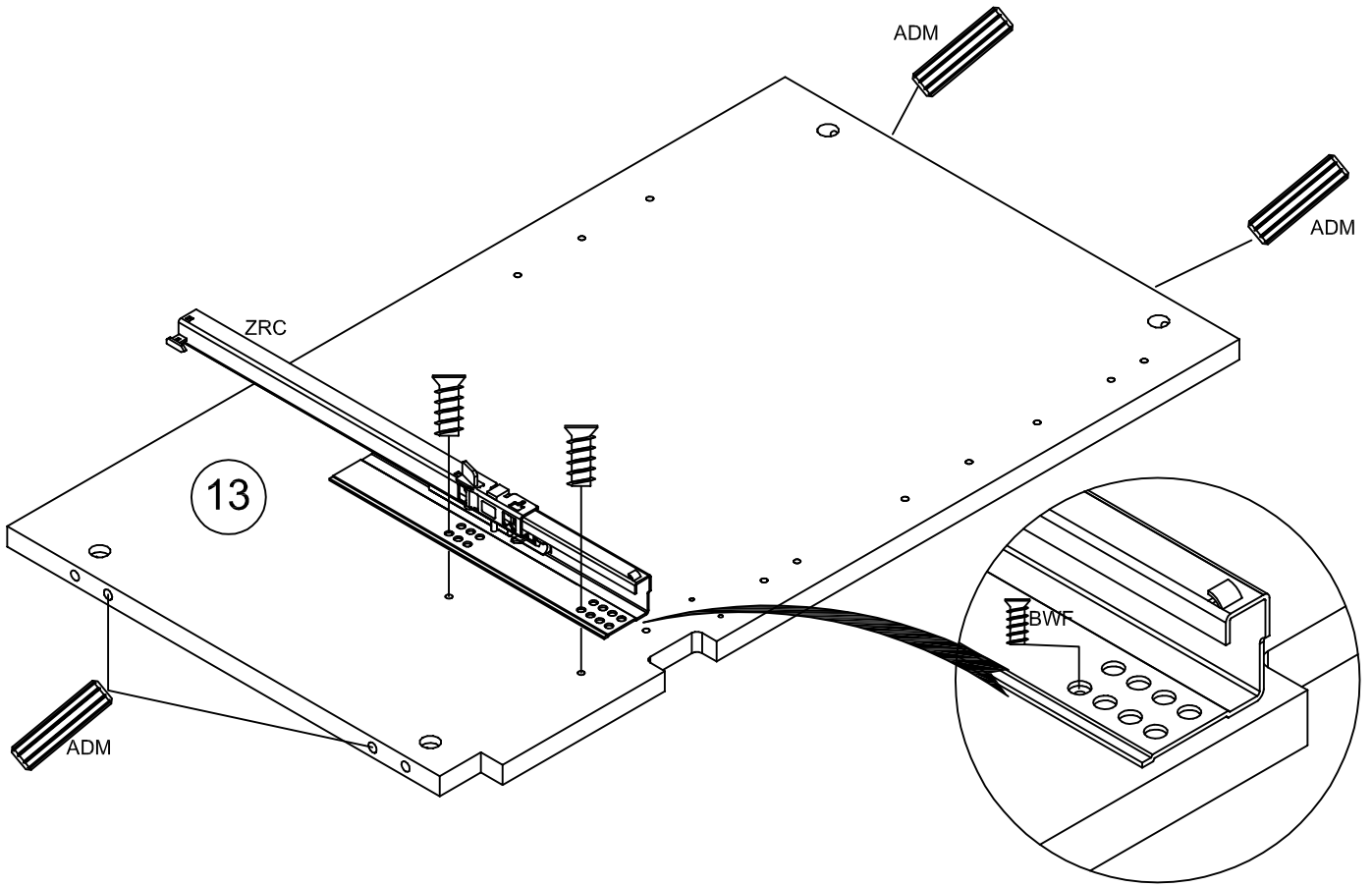

20

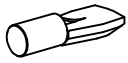

BWD x 2

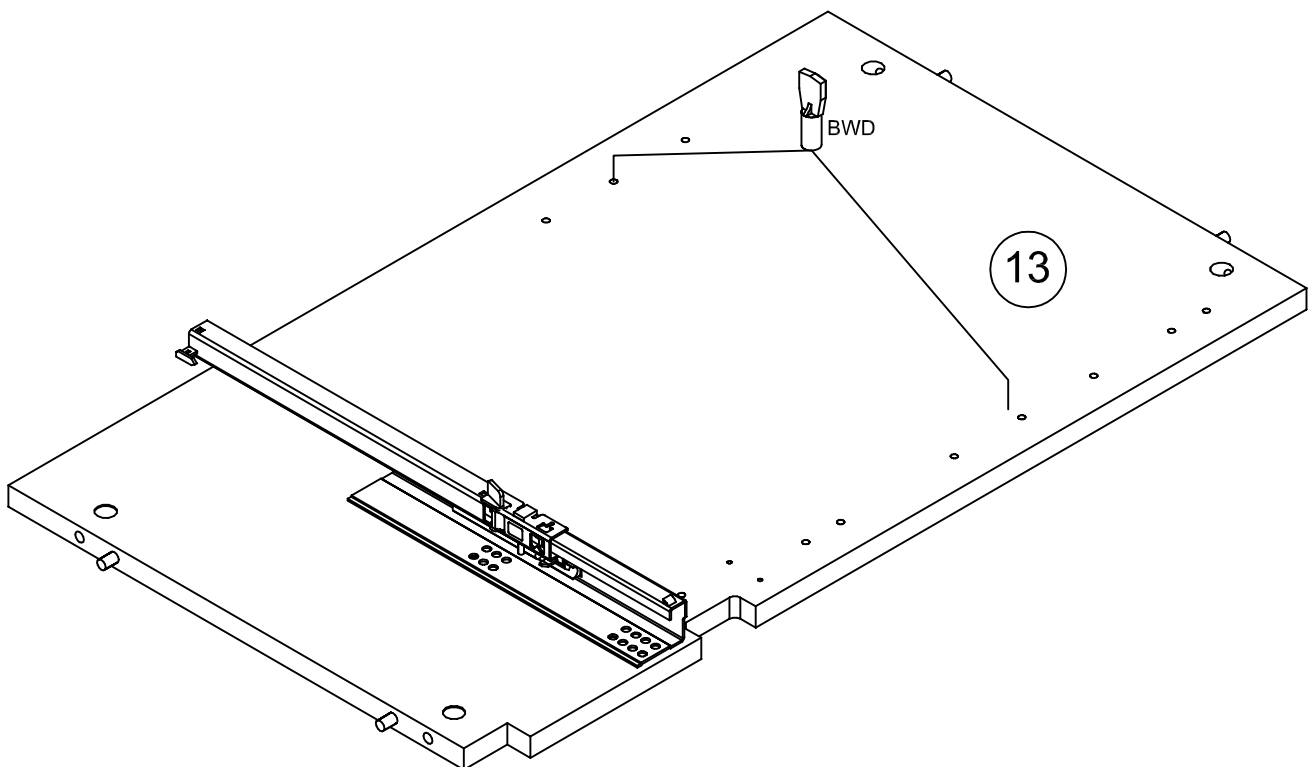

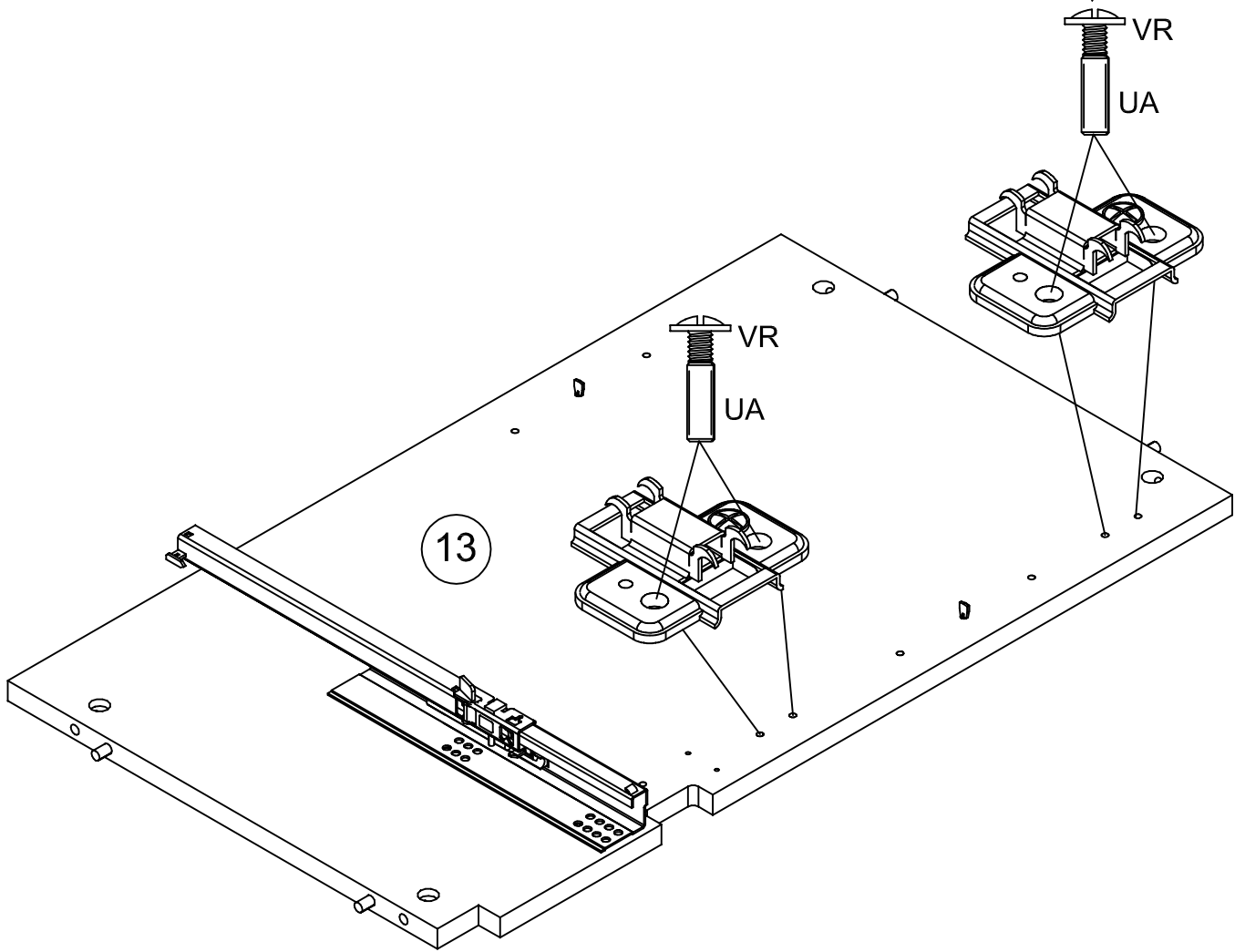
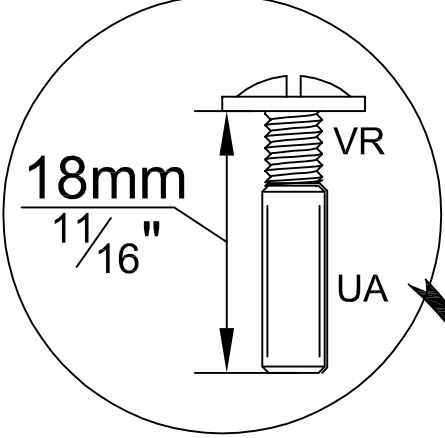
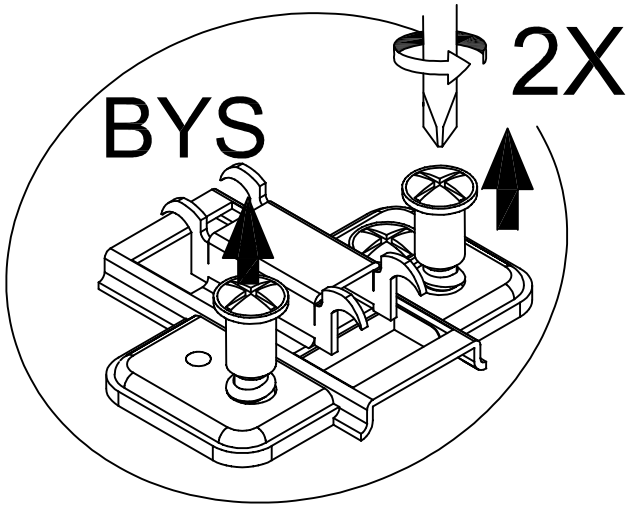
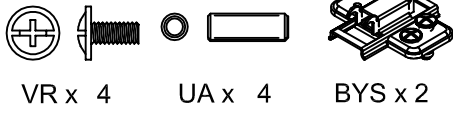

22



BWF x2

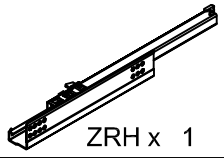

ZRH x 1

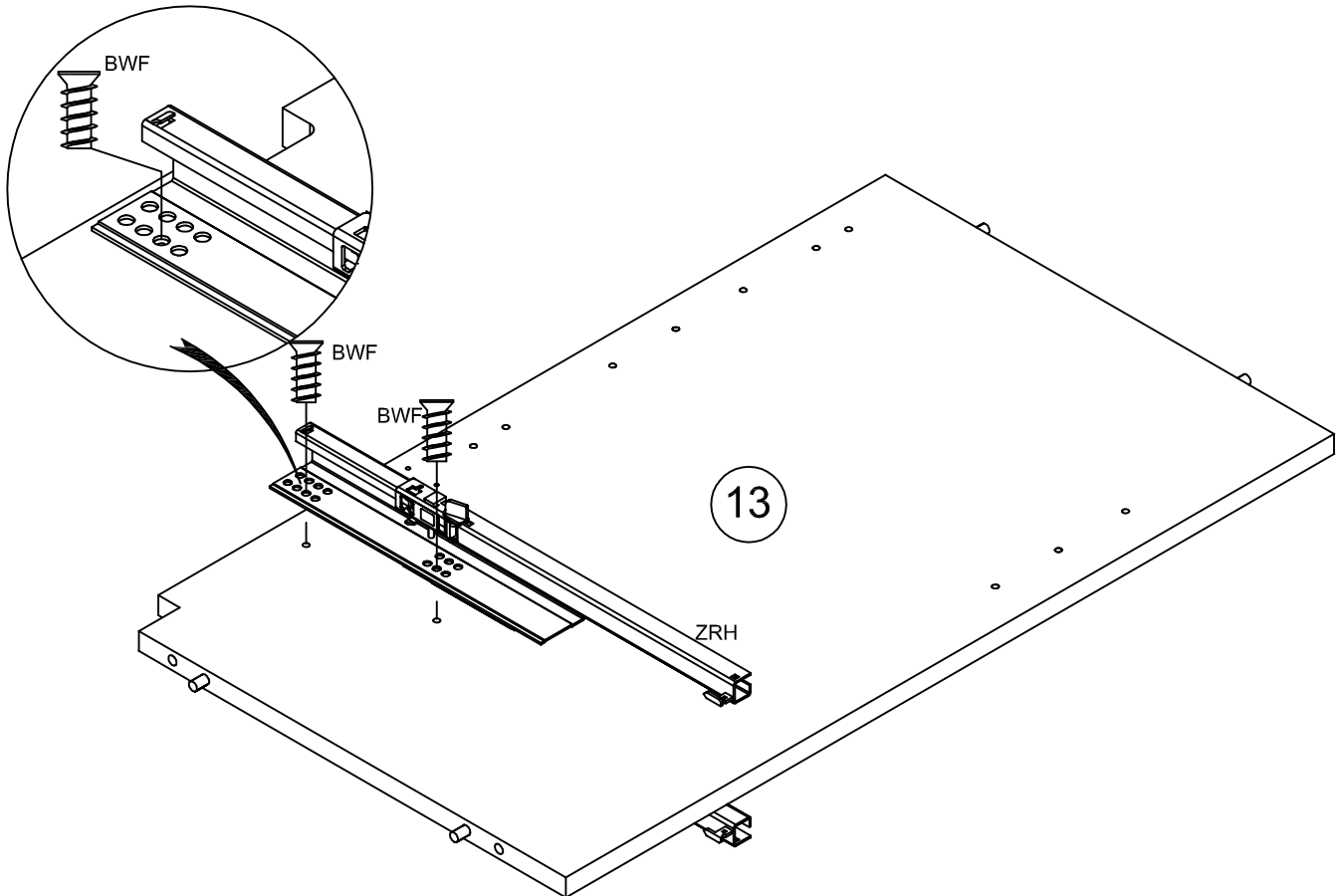

23



BWD x 2

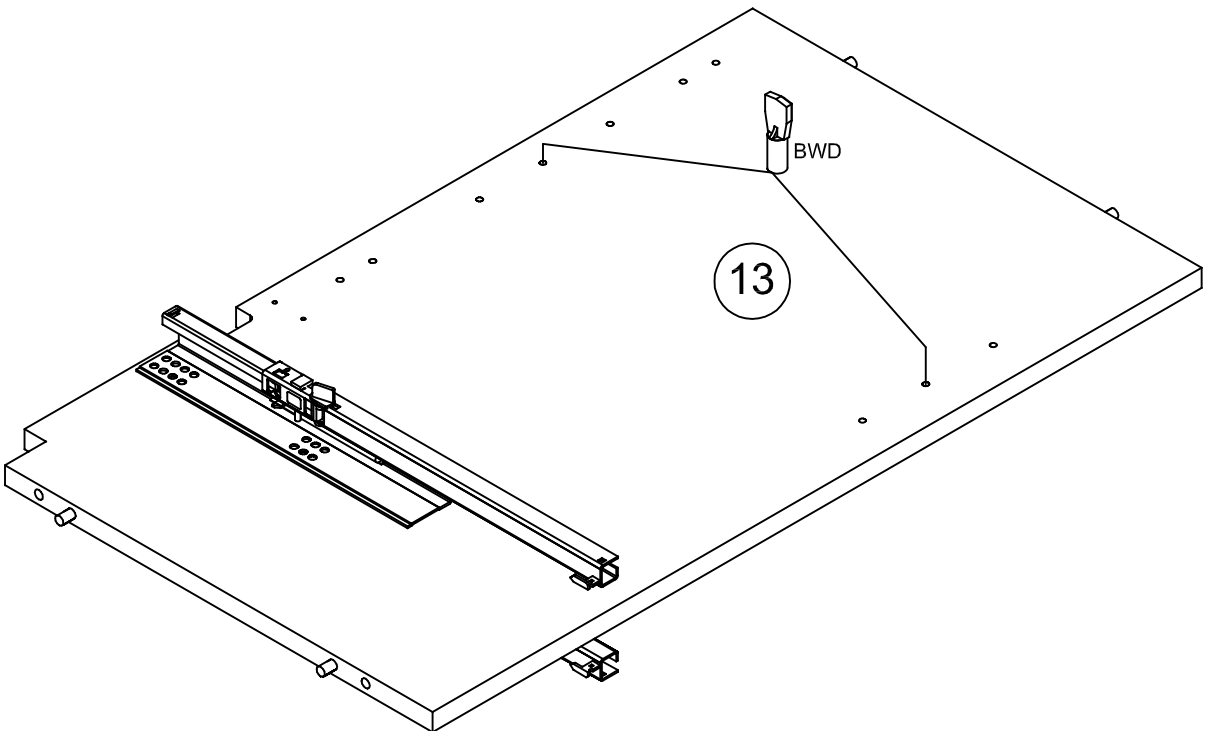



VR x 4

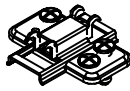

BYS x 2

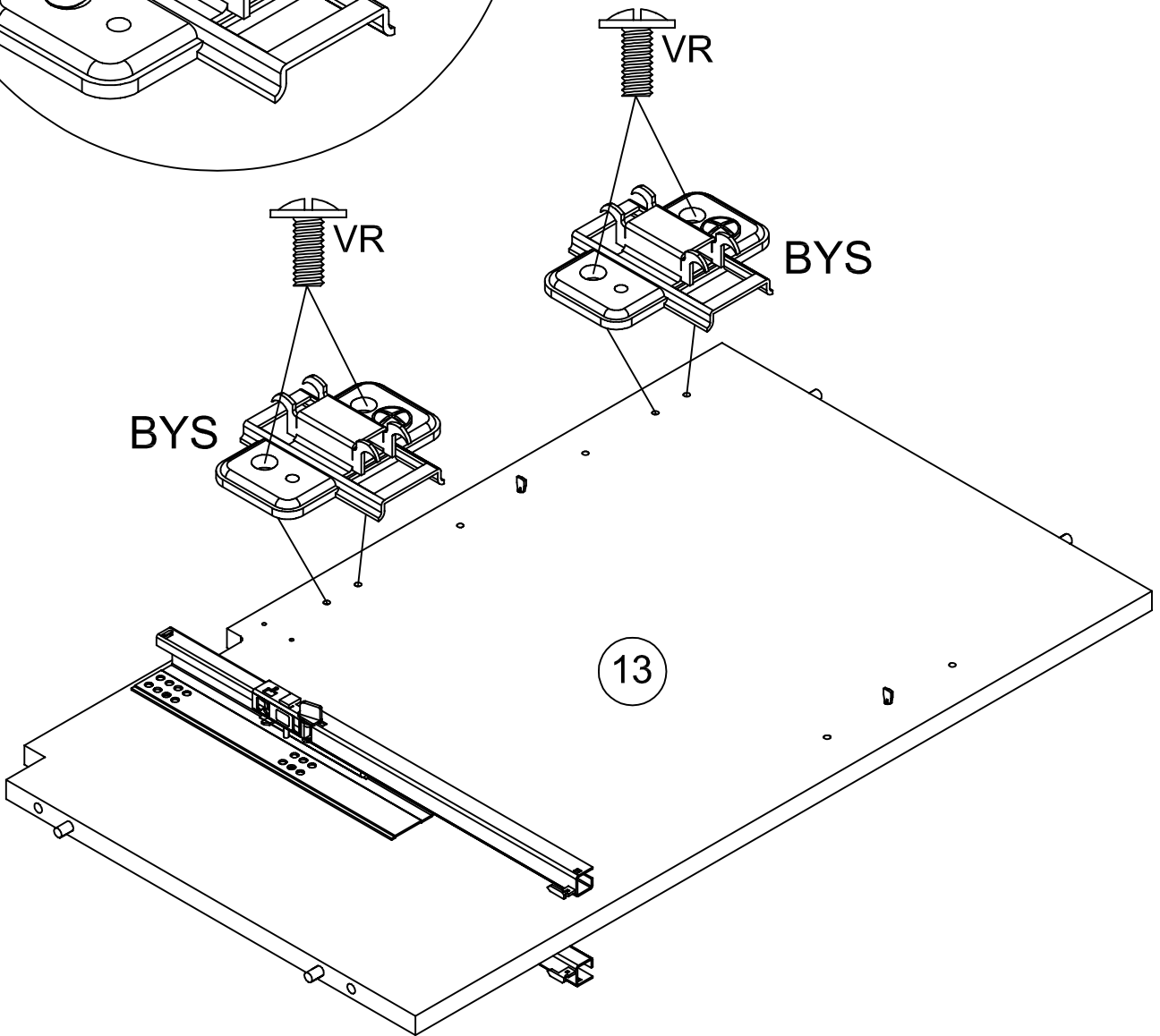
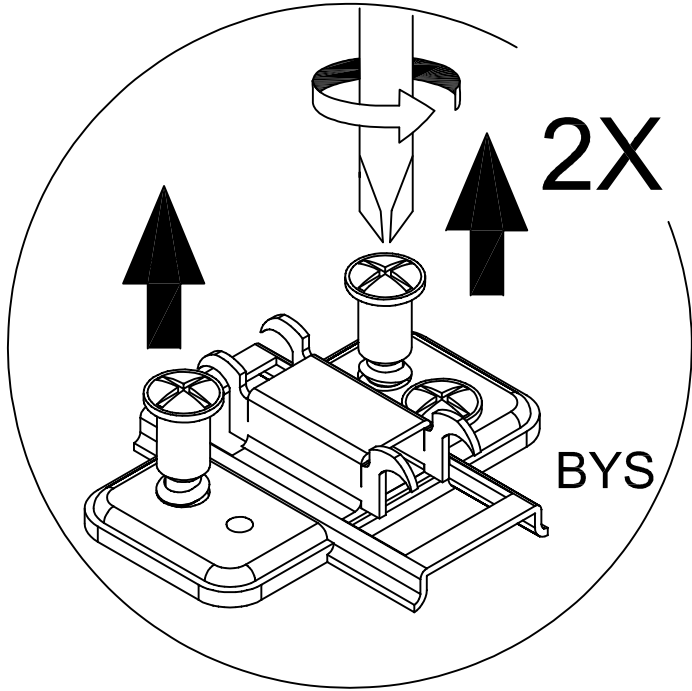

25



Ai x 2

830B

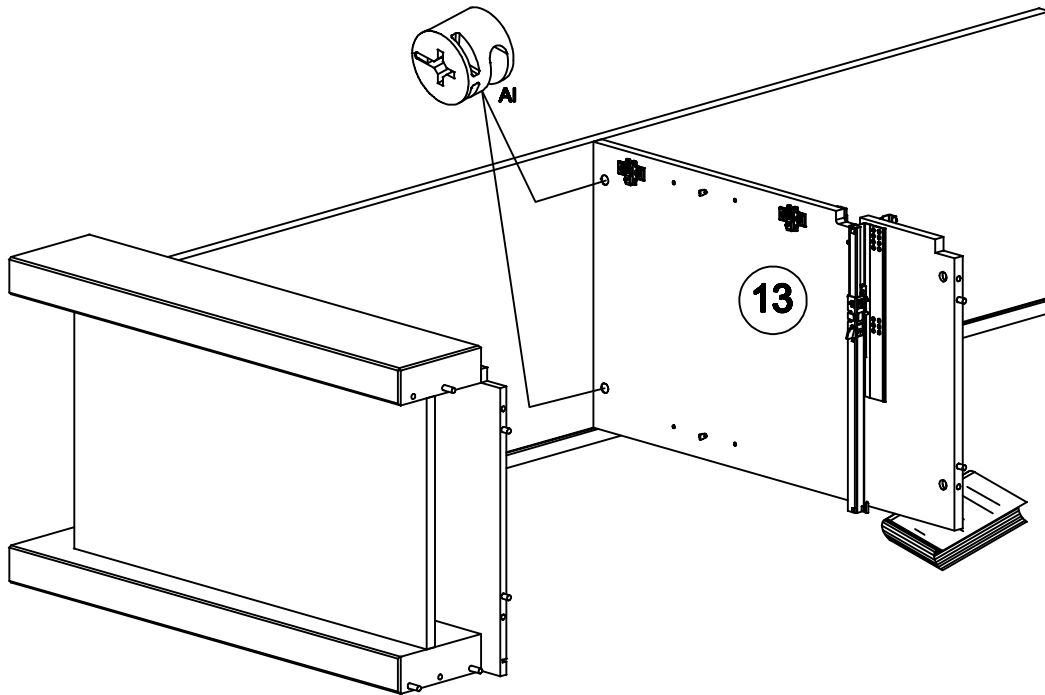

26



VB x 5

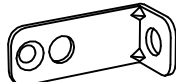

BLL x 5



ADM x 4

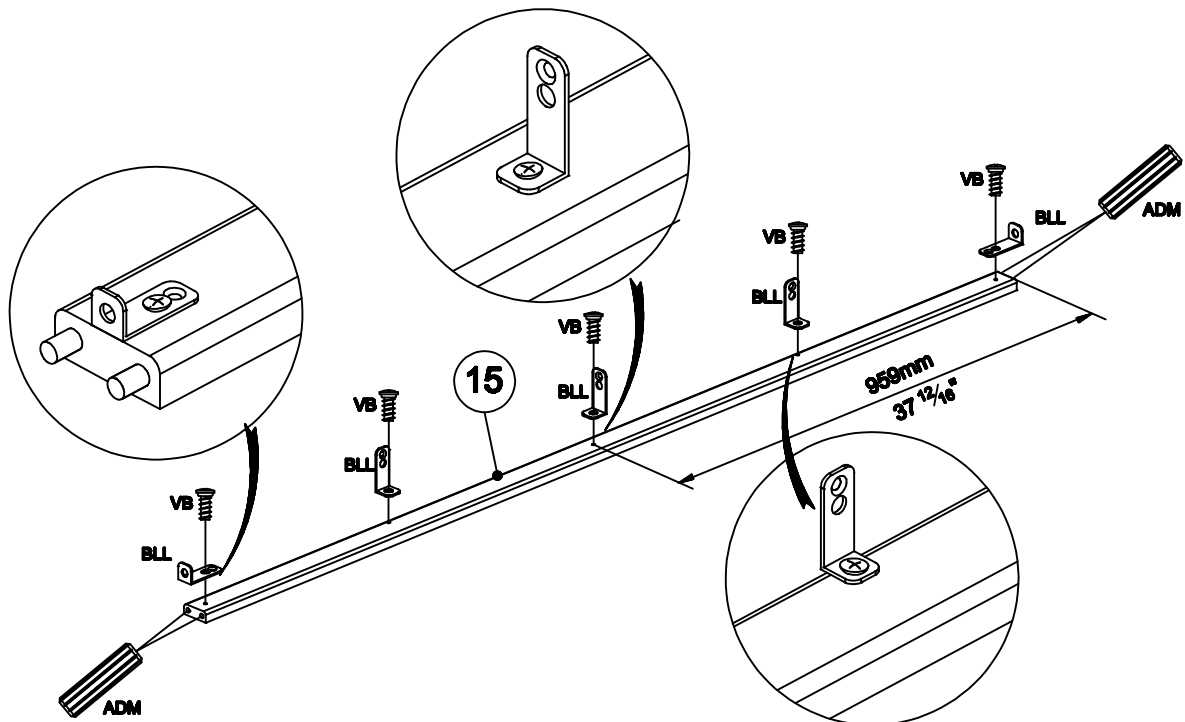

27



VB x 1

830B<sup>1</sup>

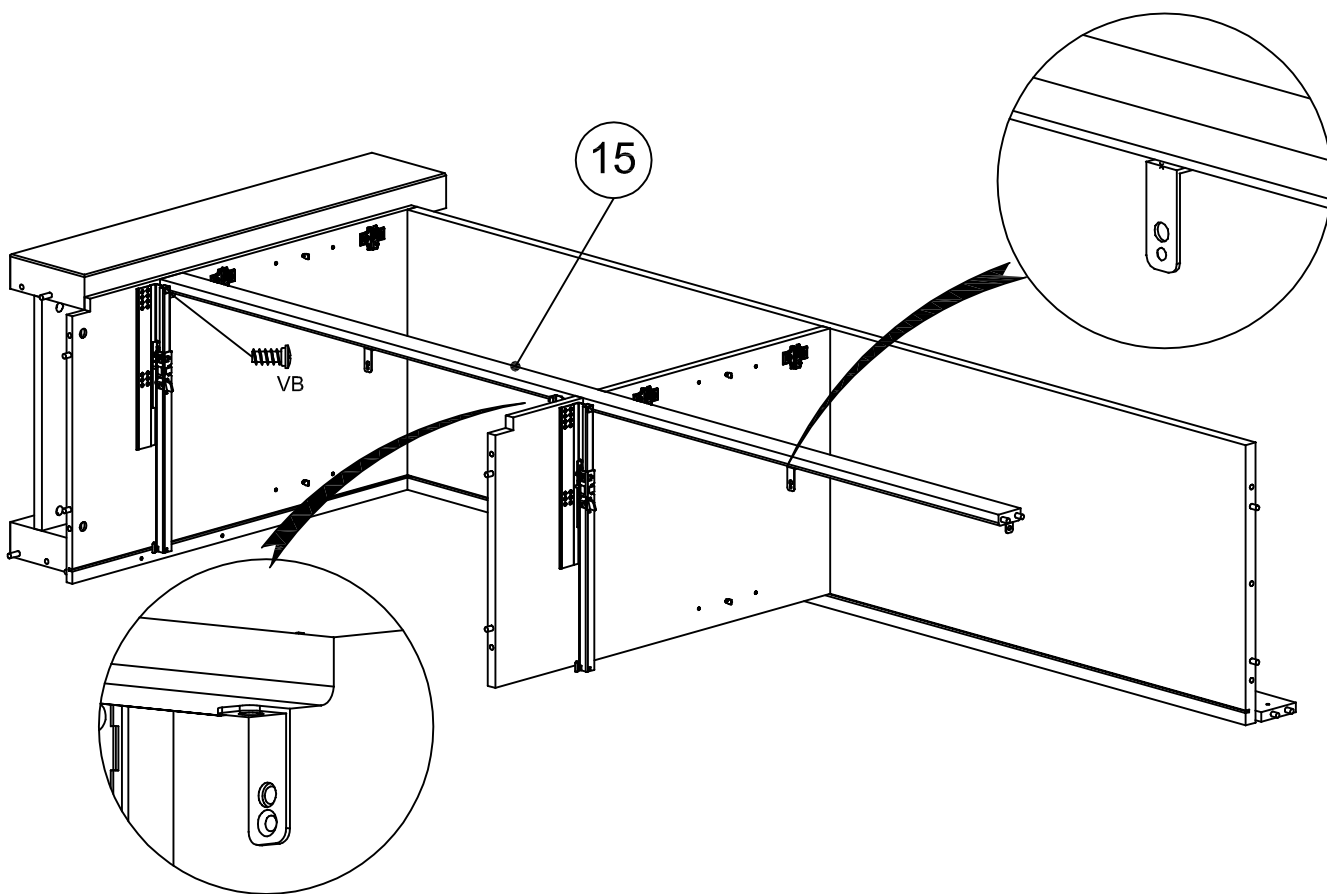

28



AI x 3



VB x 3

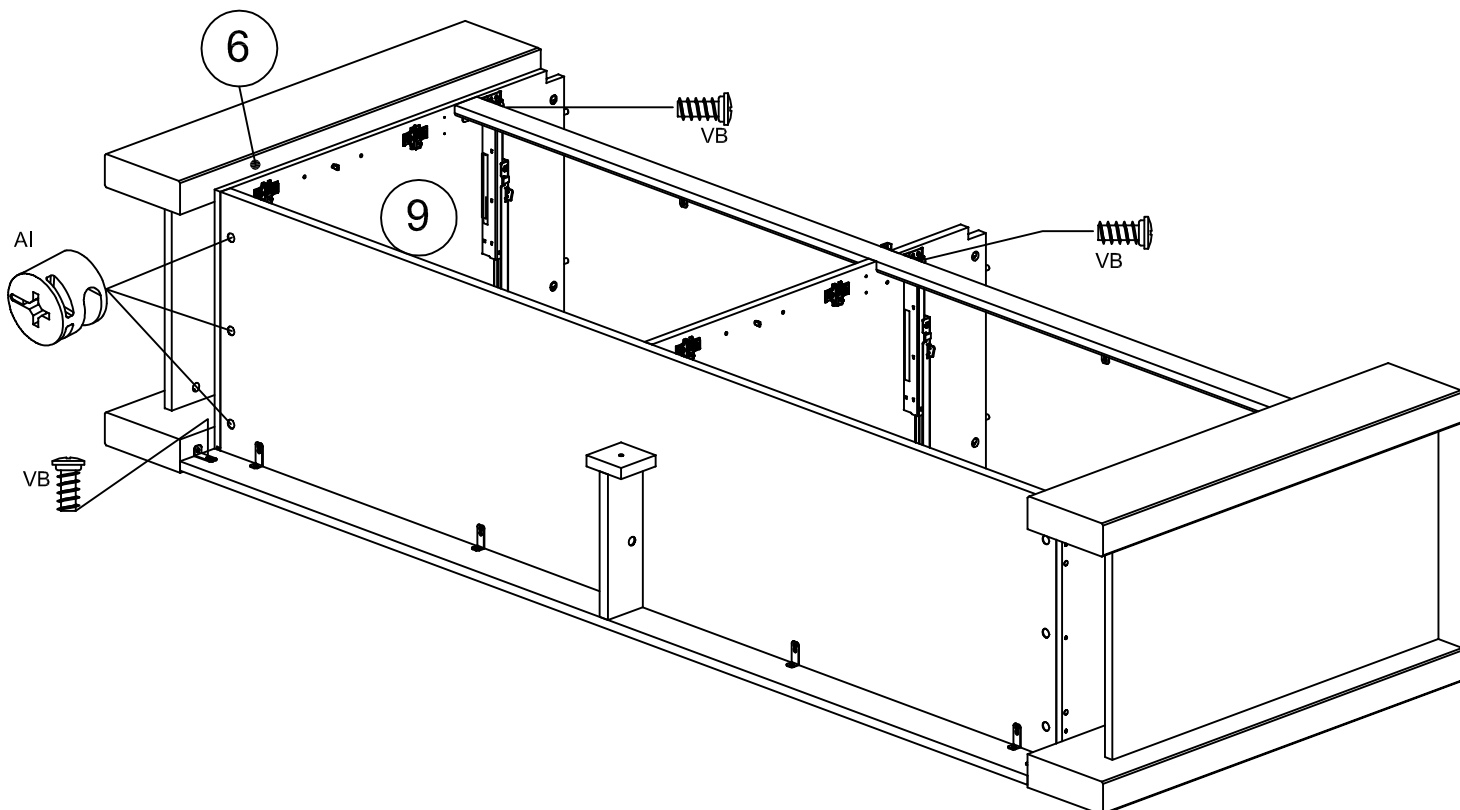

29

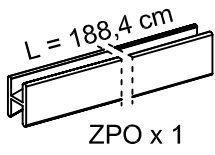

830B<sup>7</sup>

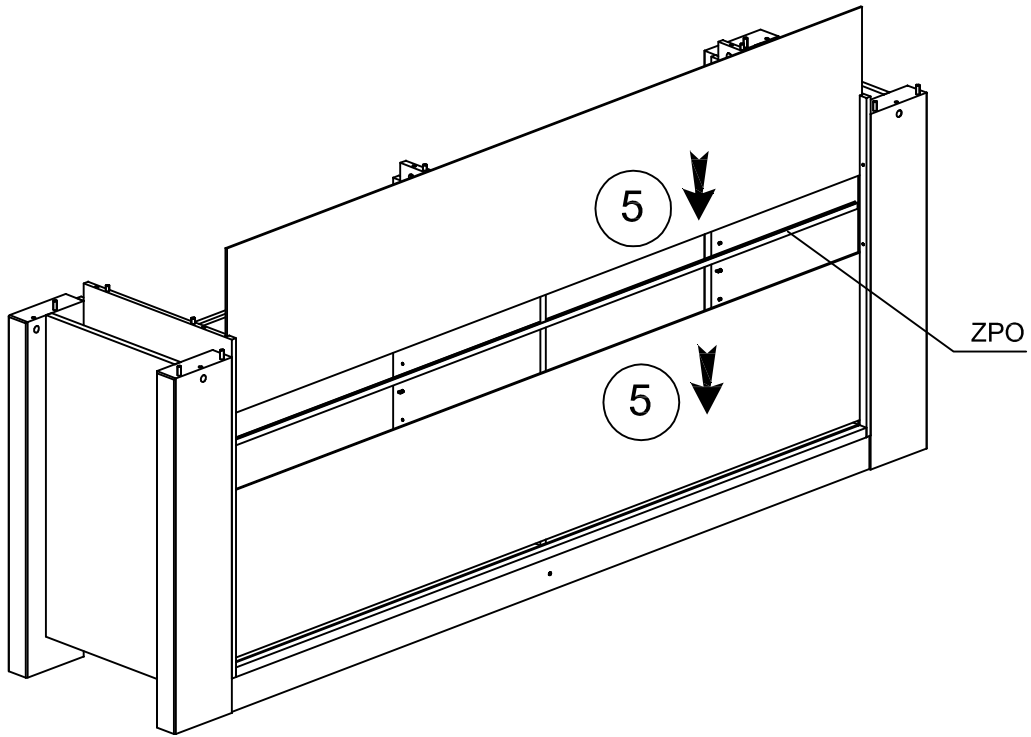

30

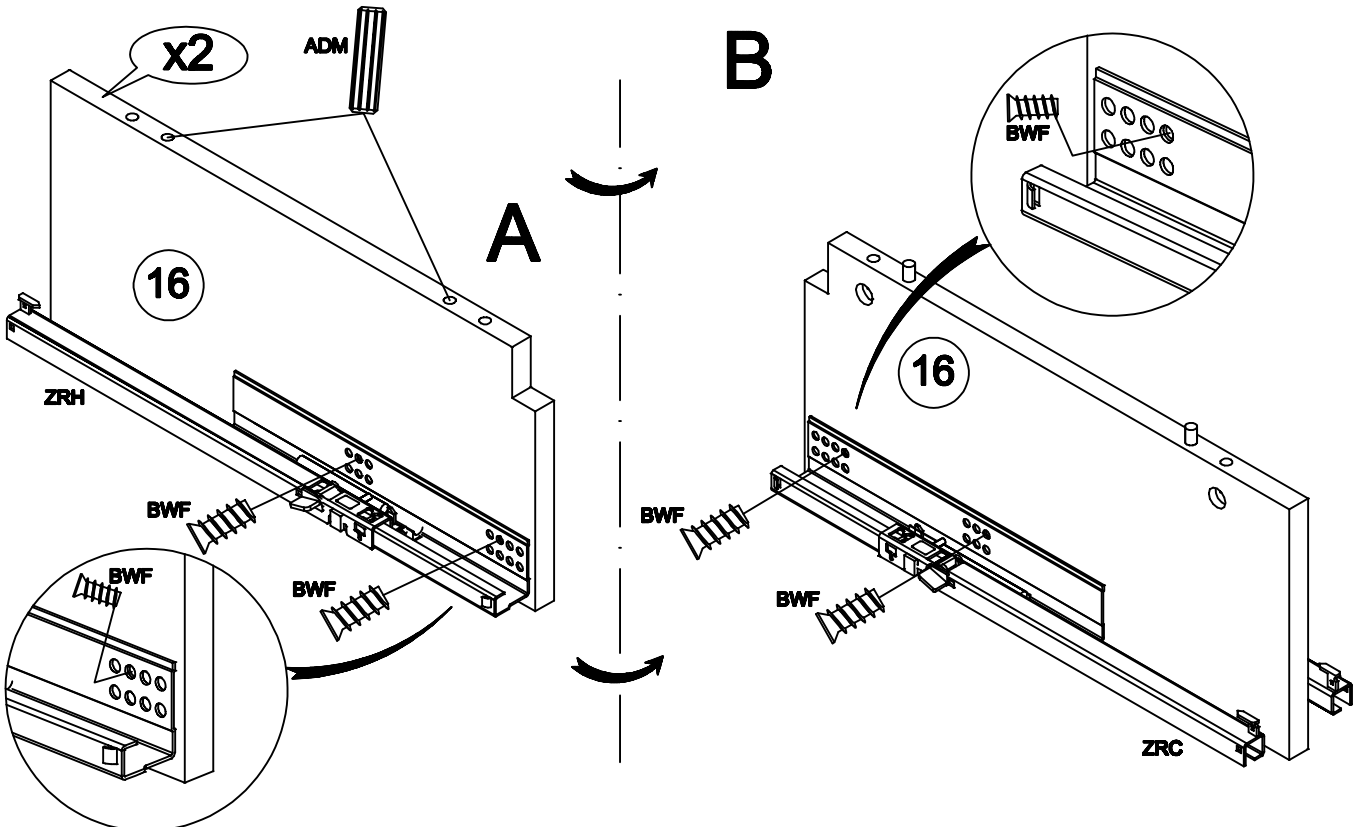
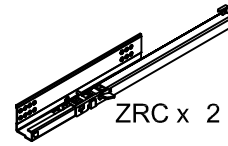
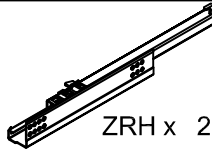
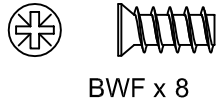

31

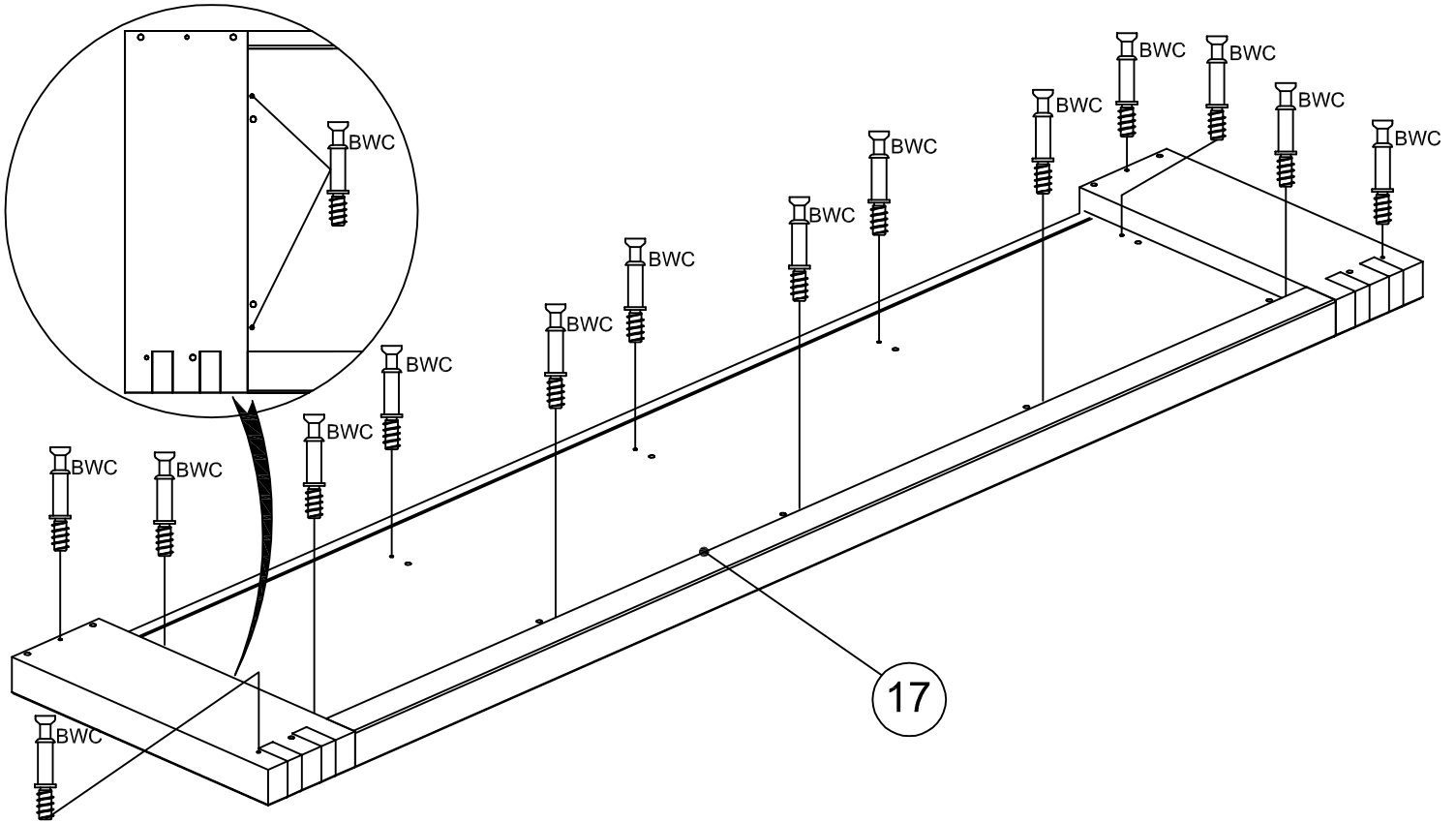
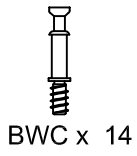

32

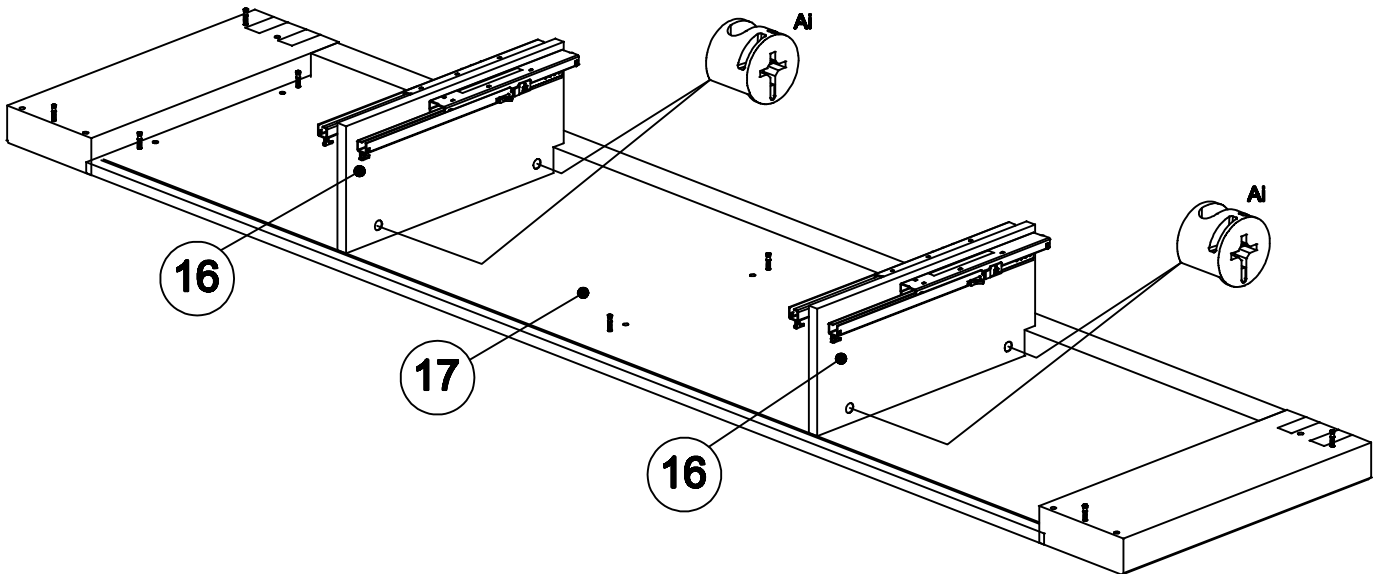



33

830B<sup>7</sup>

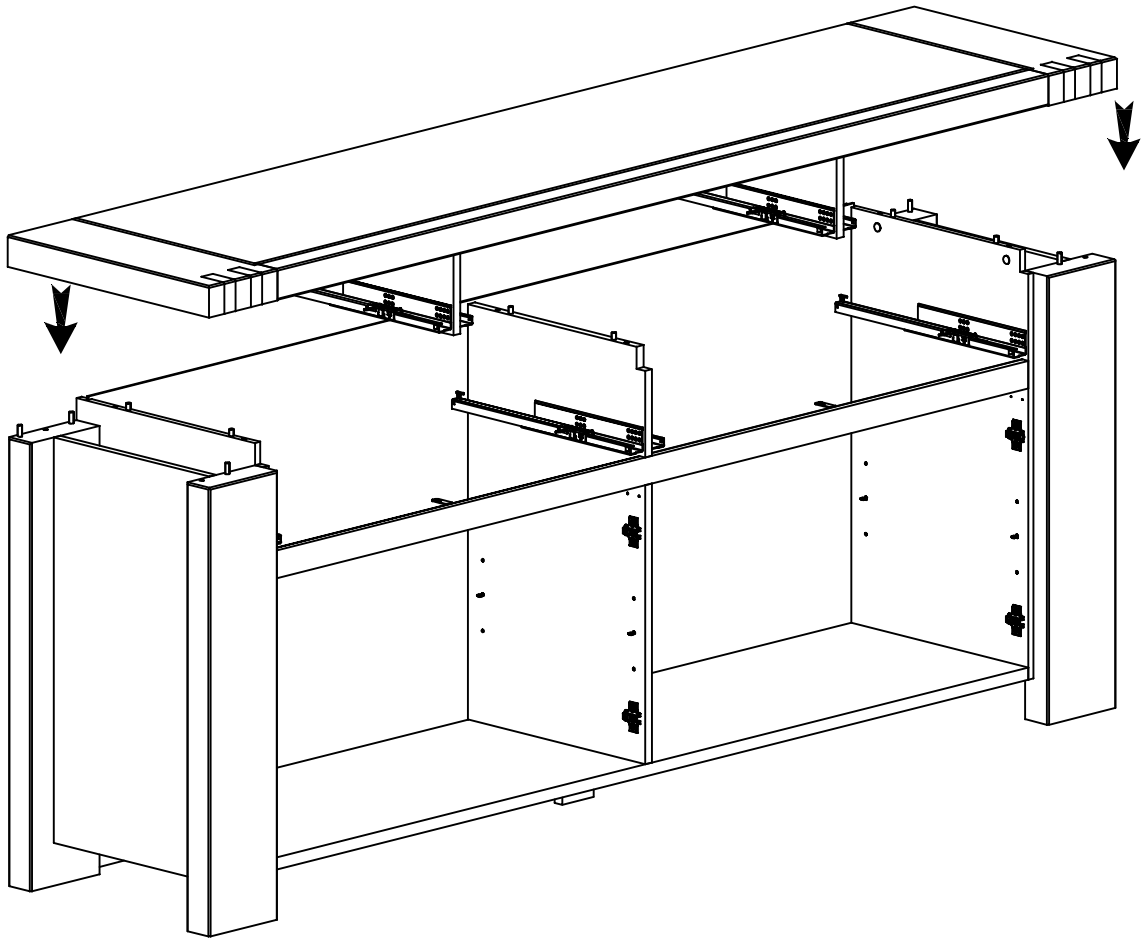

34

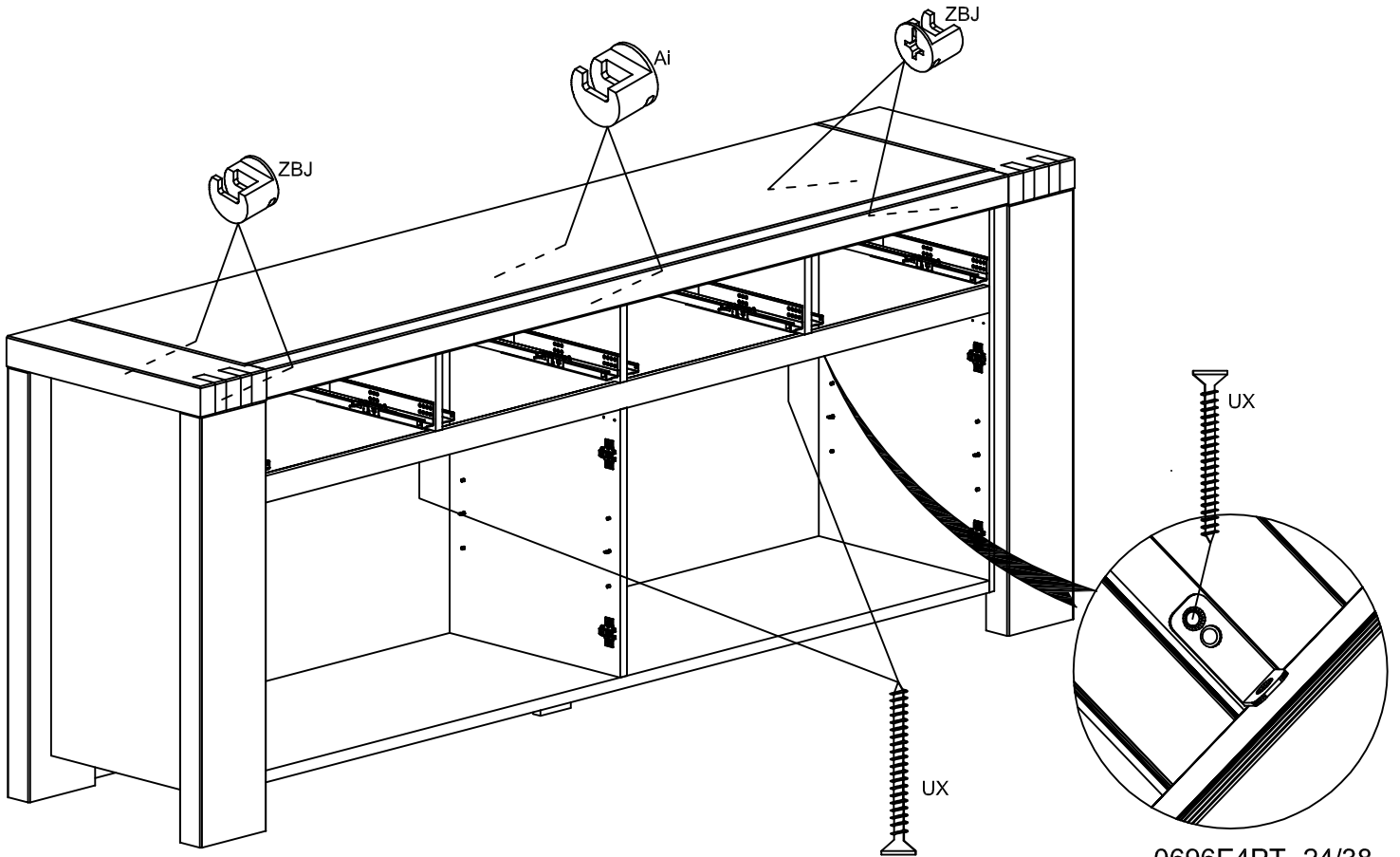
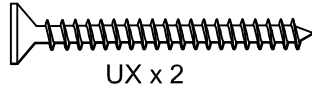

0696E4PT -24/38

35



Ai x 4

830B<sup>7</sup>

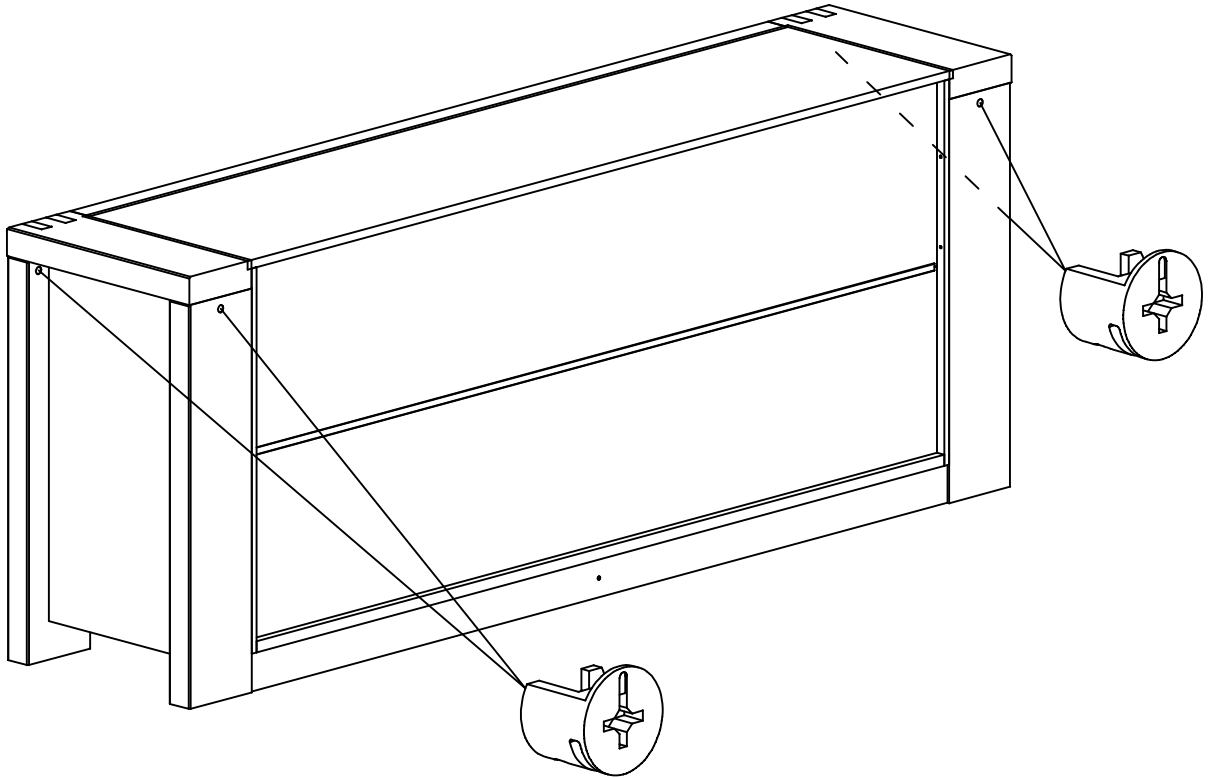

36



EP x 4

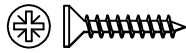

VJ x 6

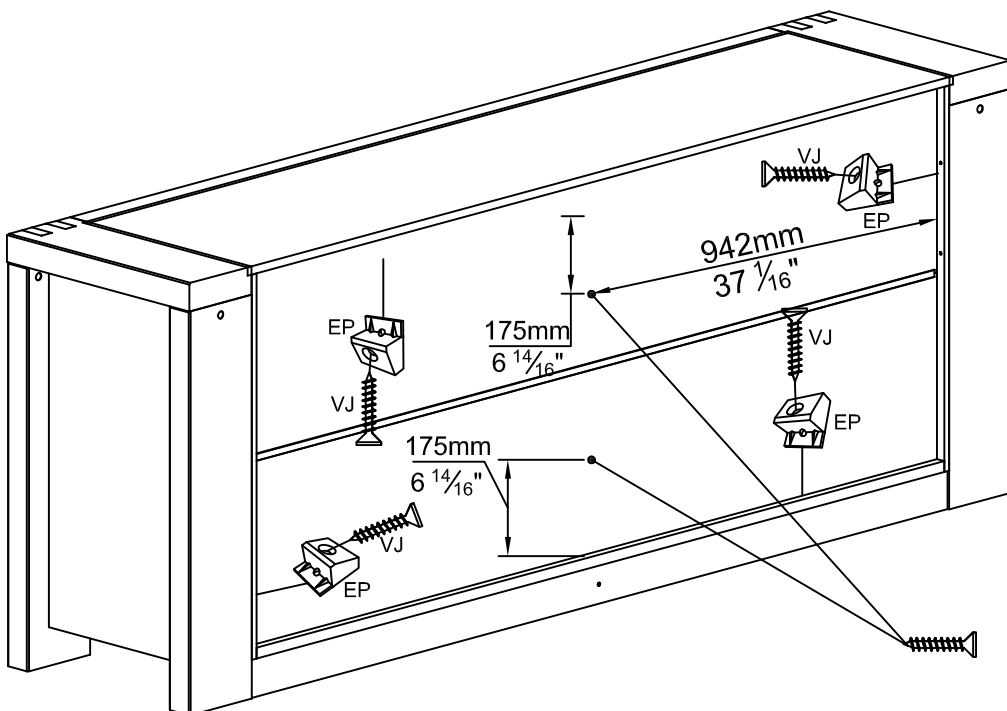

37

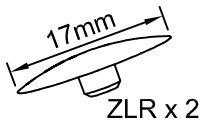

830B<sup>7</sup>

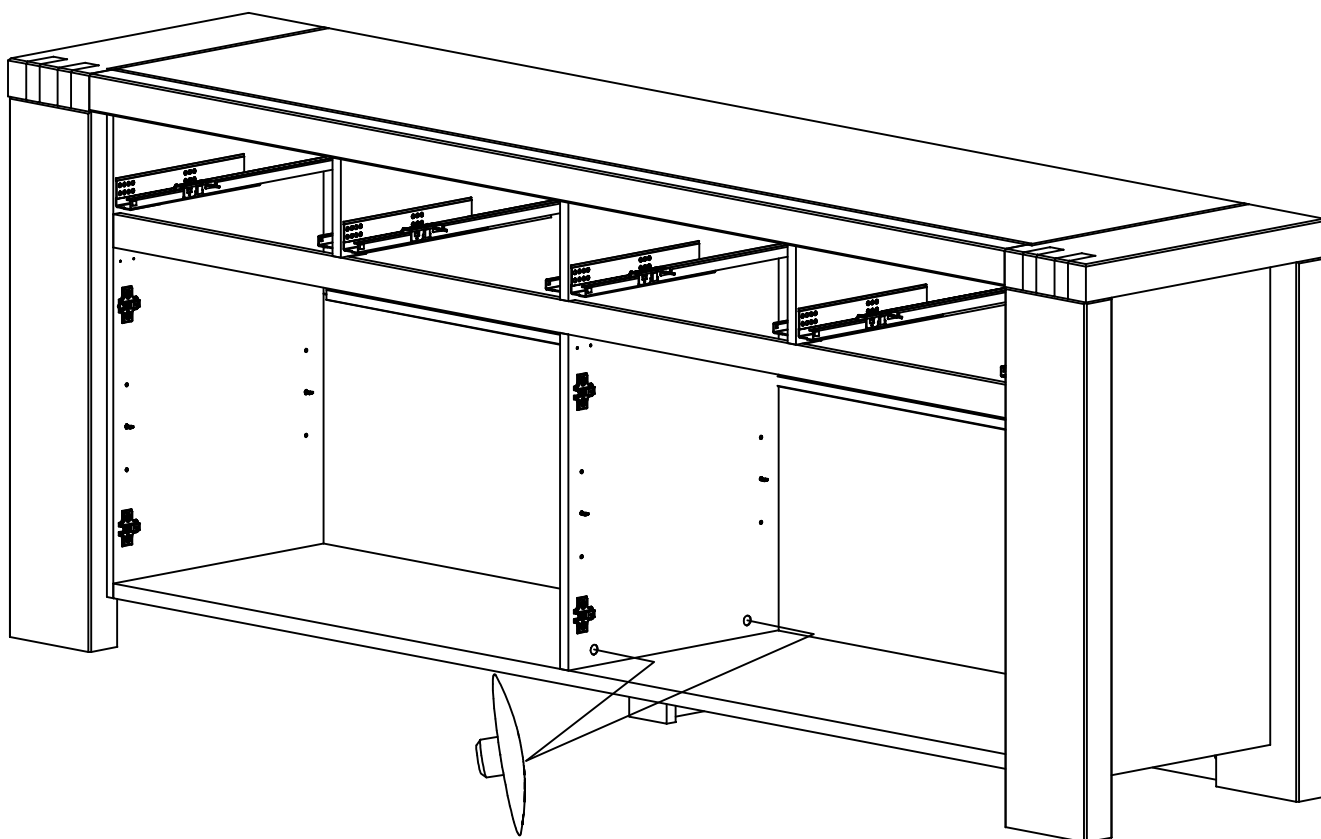

38

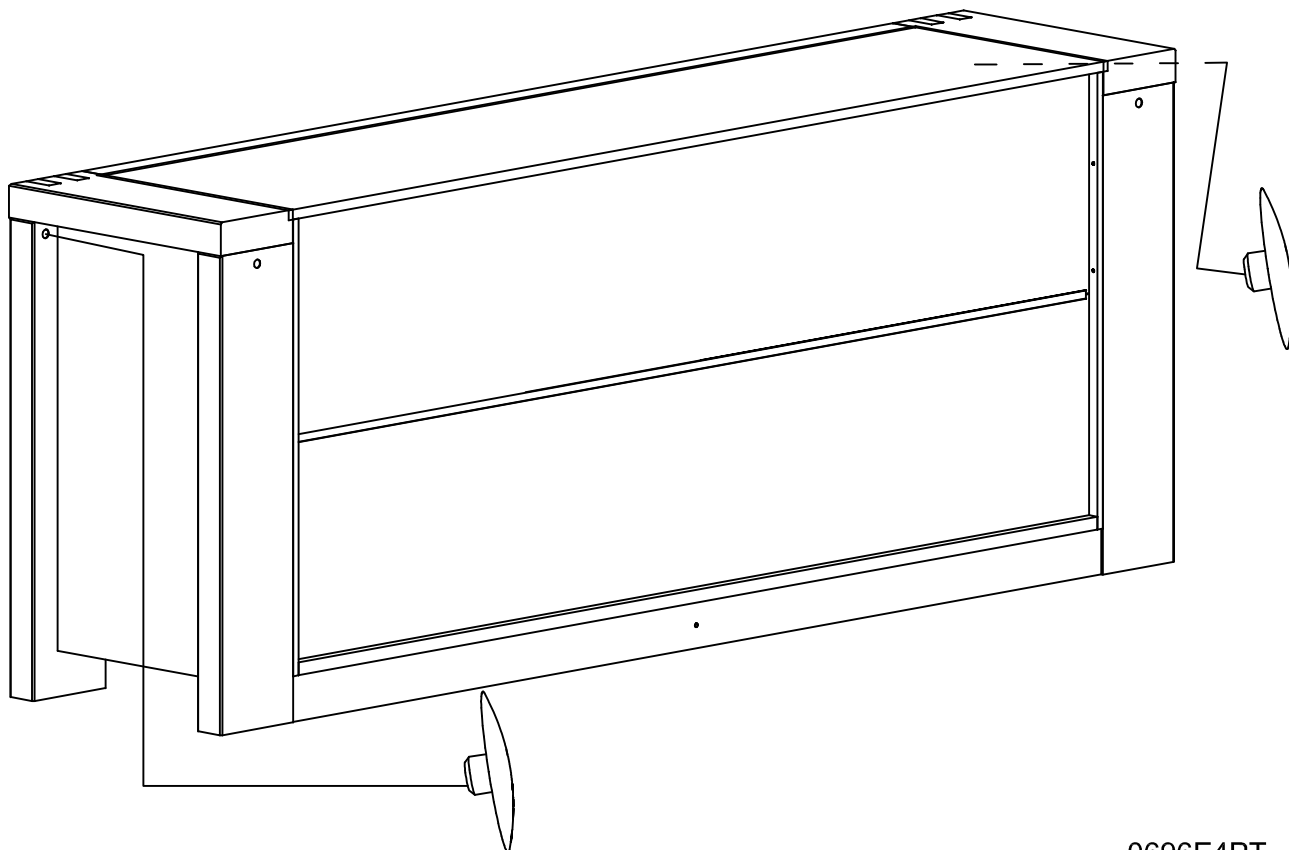
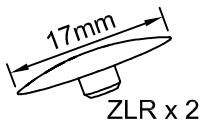

39

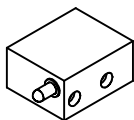

ZSS x 2



BAH x 4

830B.1

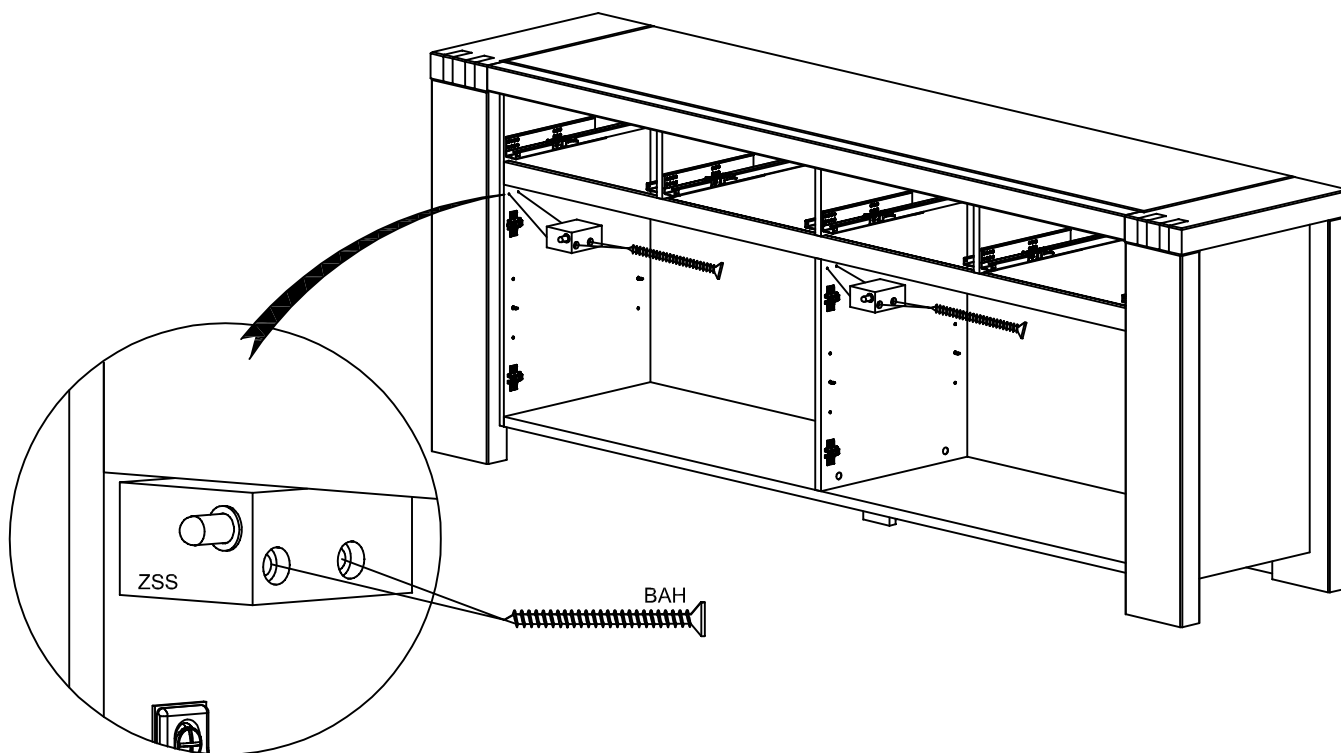

40

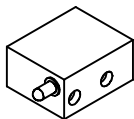

ZSS x 2



BAH x 4

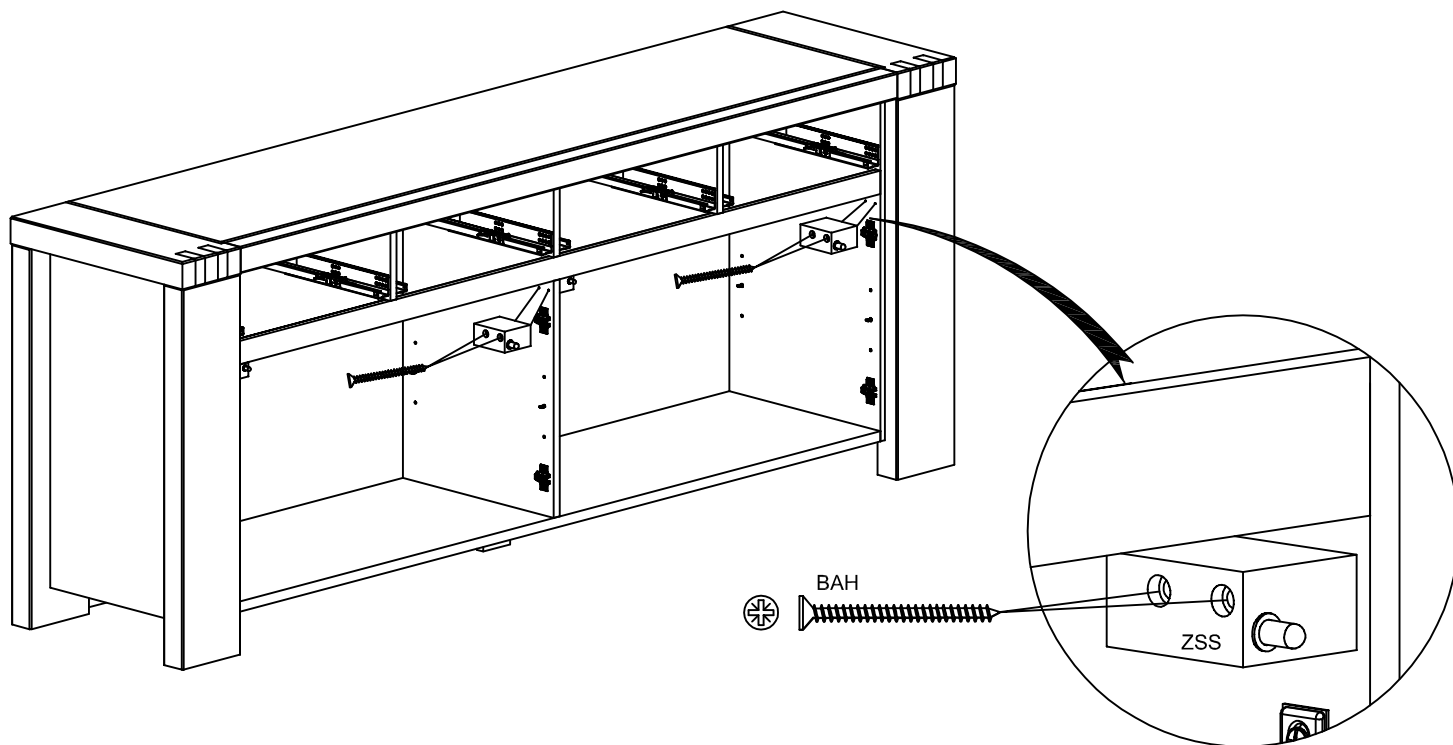

41

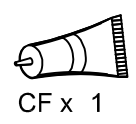
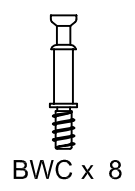

830B

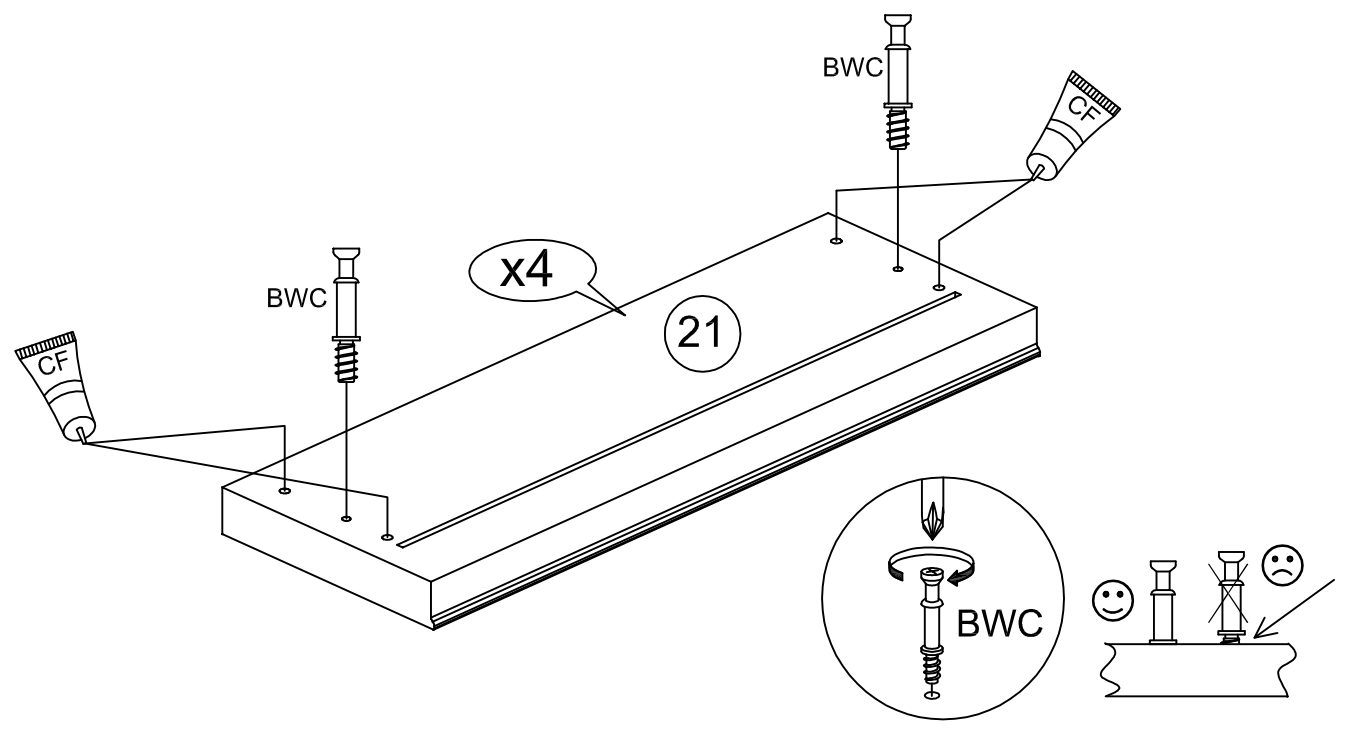

42

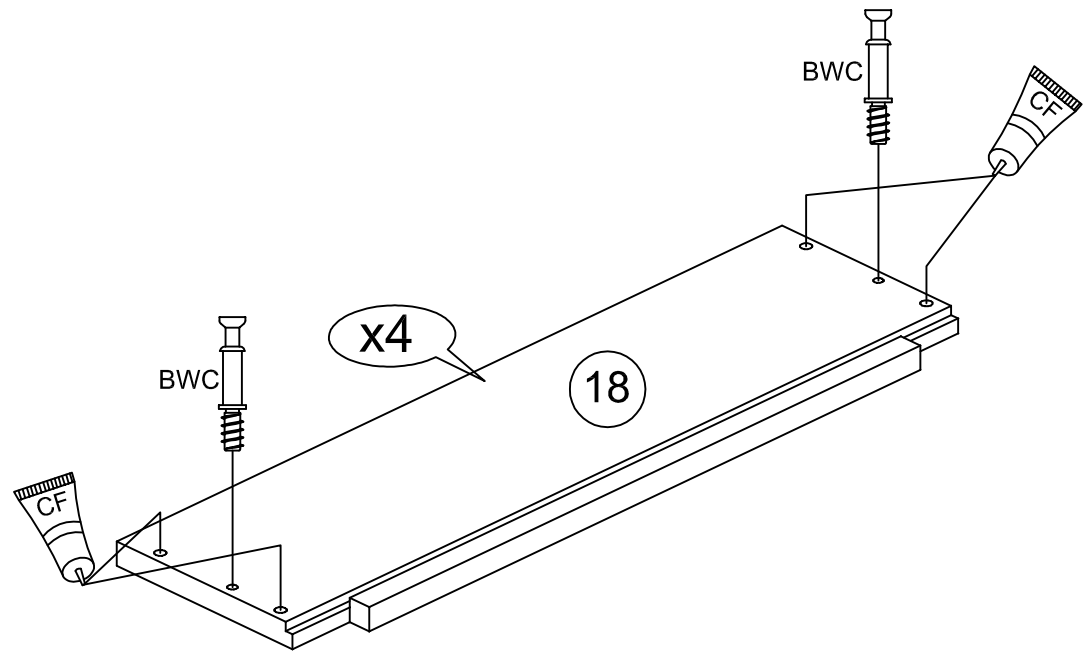
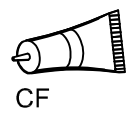
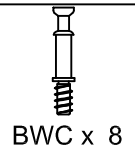

43



CFx1

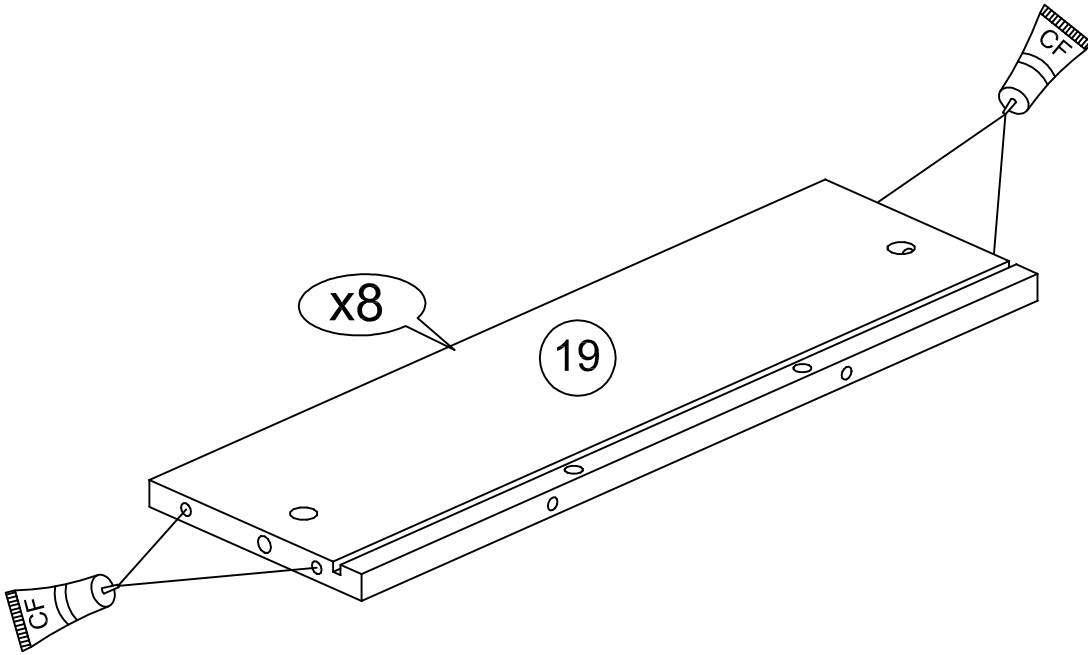

44



AV x 32

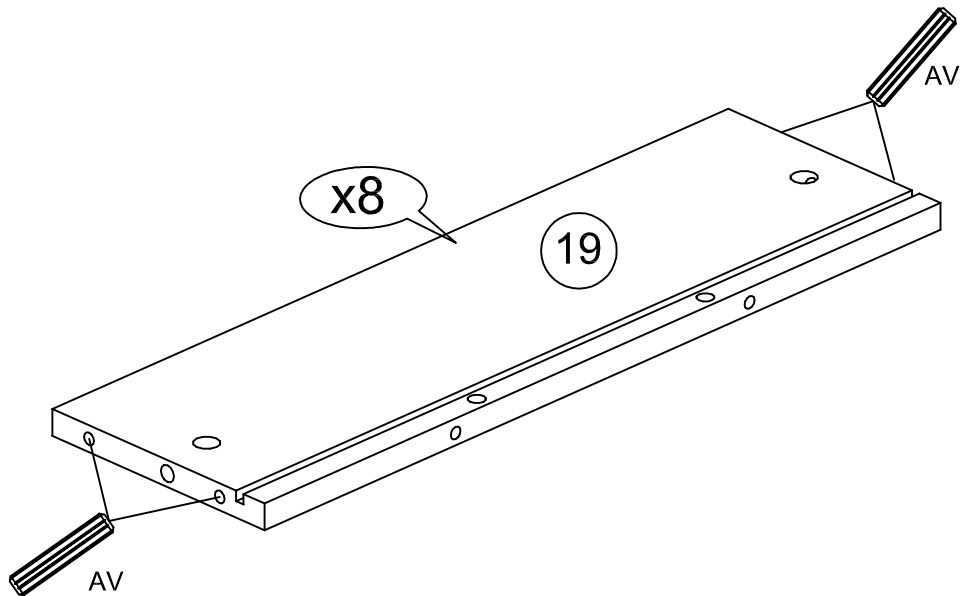

45



830B.1

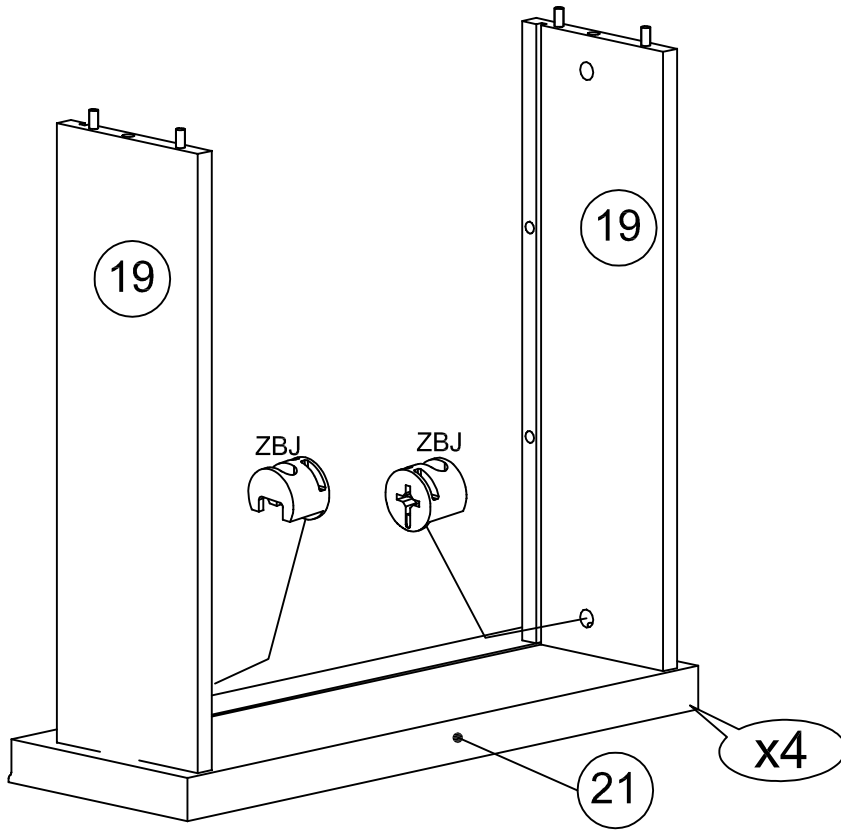

46

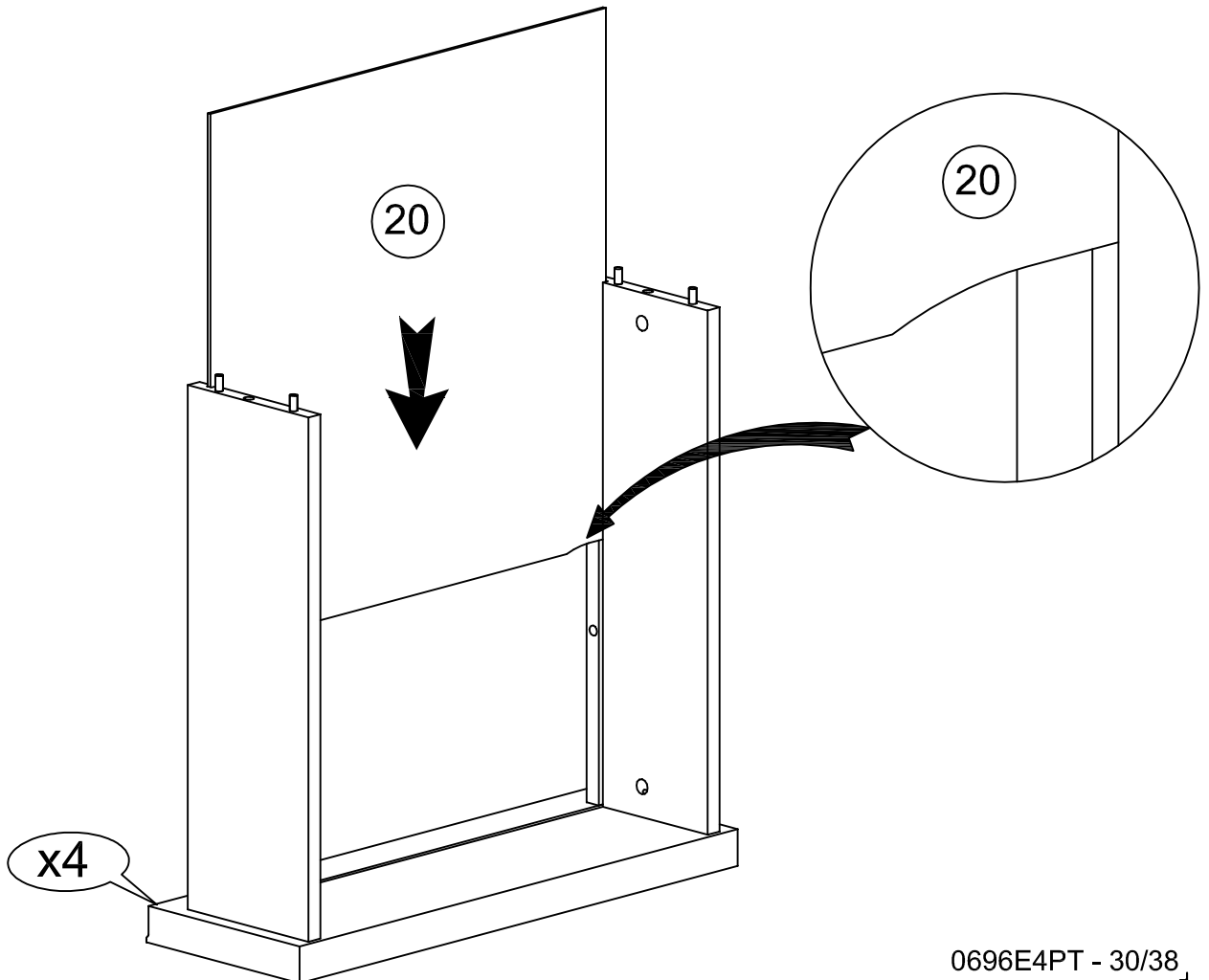

47



830B

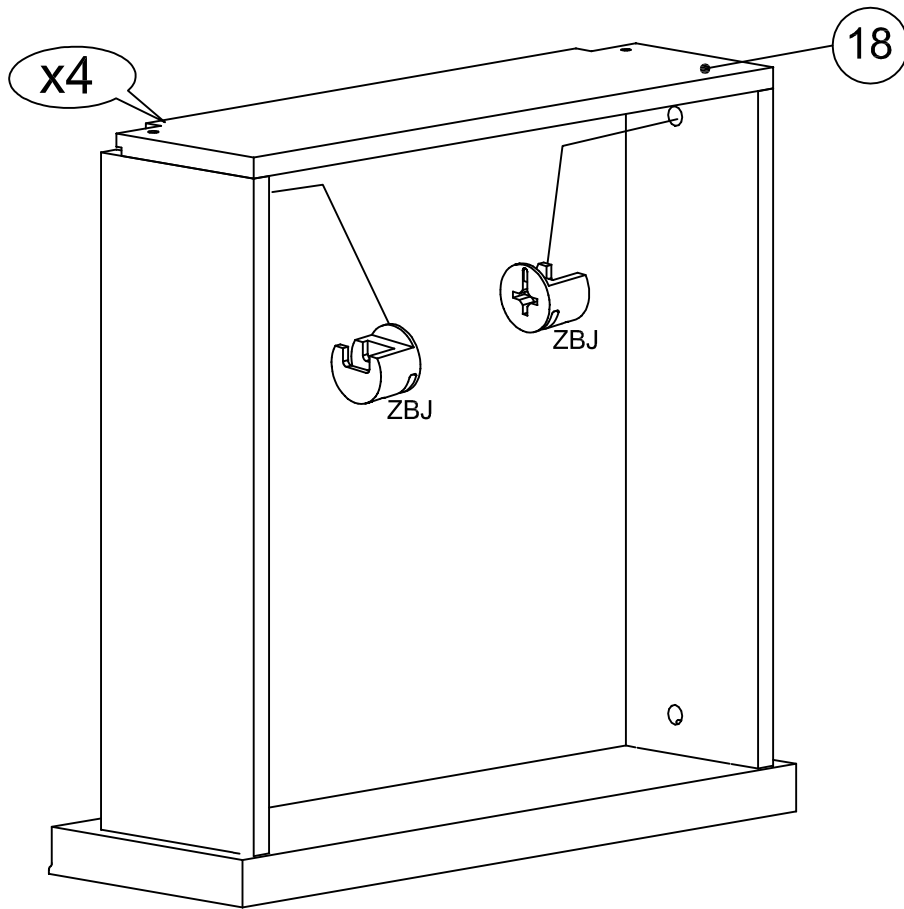

48

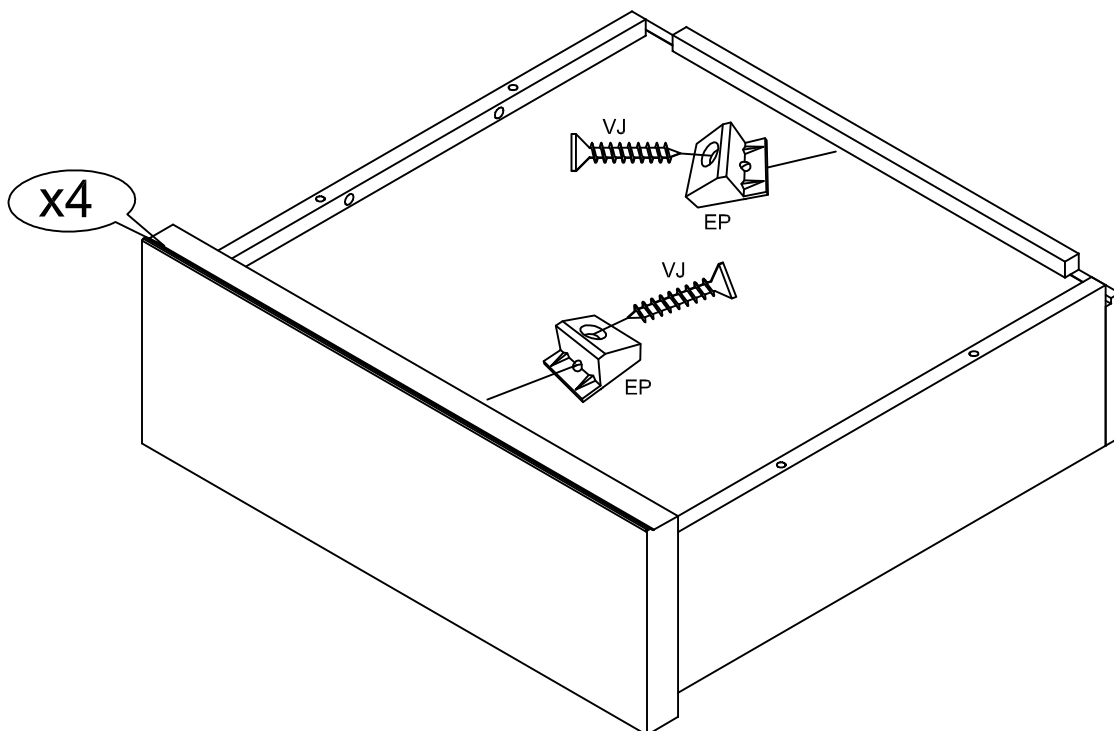
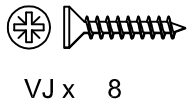



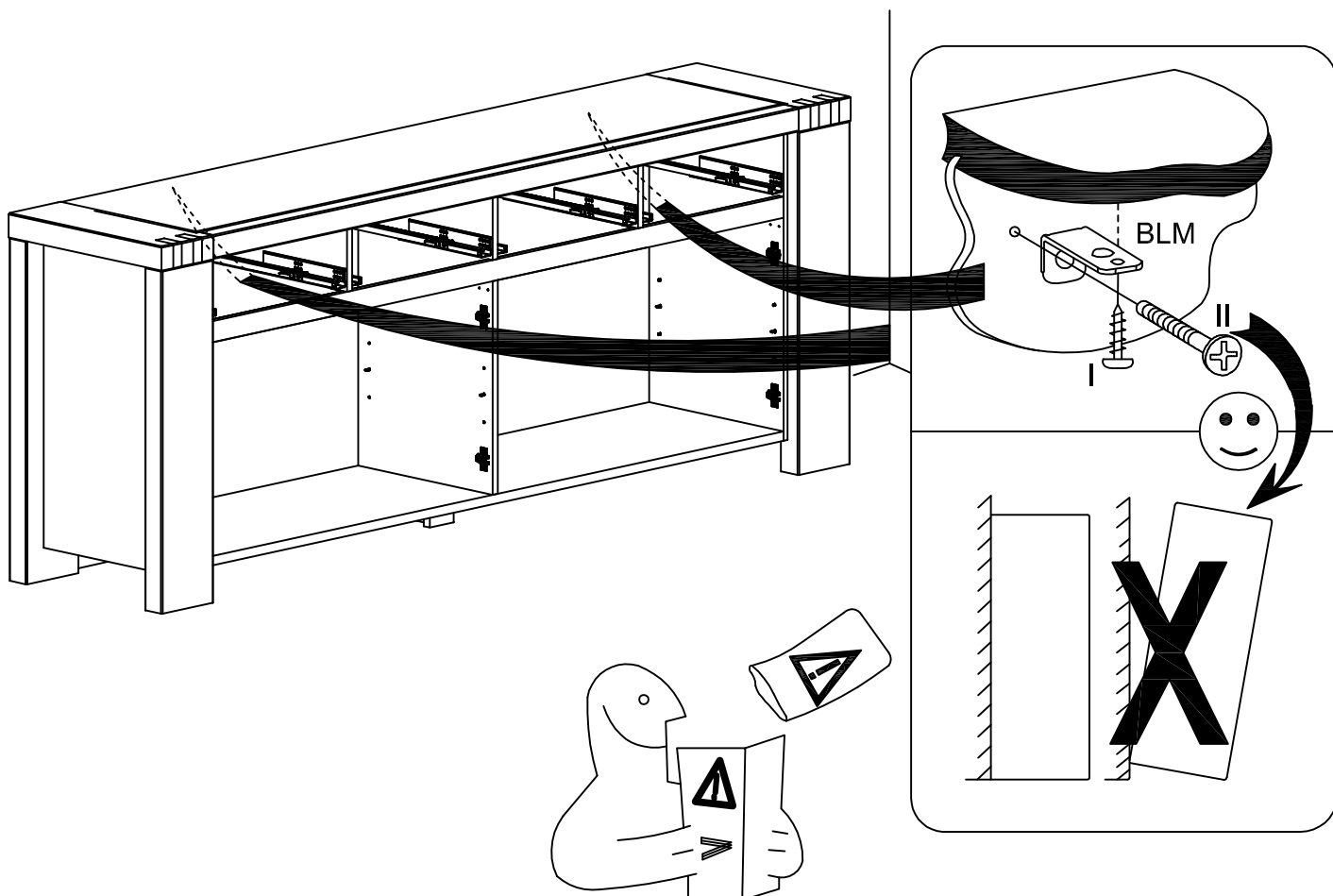
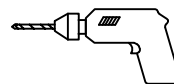

- (FR) Pour votre sécurité: Fixation du meuble au mur Attention, la fixation doit être réalisée par une personne competente car cela necessite des chevilles adaptees a la nature de votre mur.
- (GB) For your own safety: attach the furniture to the wall. Important: The furniture must be attached by a qualified person using dowels that are suited to the type of wall.
- (D) Für ihre Sicherheit: Befestigung des Möbelstücks an der Wand Achtung, die Befestigung muss von einem Fachmann vorgenommen werden, weil sie an die Wand angepasste Dübel erfordert.
- (E) Para su seguridad: Fijación del meuble a la pared Ojo! La fijación deberá llevarla a cabo una persona competente ya que necesitará unos tacos adaptados a tipo de pared.
- (PT) Para a sua segurança: Fixação do móvel na parede. Atenção, a fixação deve ser efectuada por uma pessoa competente, pois exige a utilização de cavilhas adaptadas à natureza da parede.
- (I) Per la vostra sicurezza: fissaggio del mobile alla parete. Nota bene, il fissaggio deve essere eseguito da personale specializzato, poiché l'utilizzo di tasselli adattati alla parete.
- (NL) Voor uw veiligheid: Bevestiging van het meubel aan de muur. Let op, de bevestiging moet worden uitgevoerd door een bevoegd persoon, want hiervoor zijn pluggen nodig die specifiek geschikt zijn voor de betreffende muur.
- (RO) Atentiune: mobilierul trebuie să fie fixat de către o persoană calificată care să utilizeze suruburi adaptate tipului de perete

50

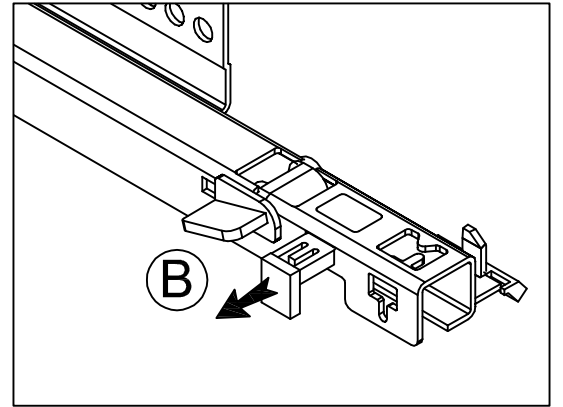
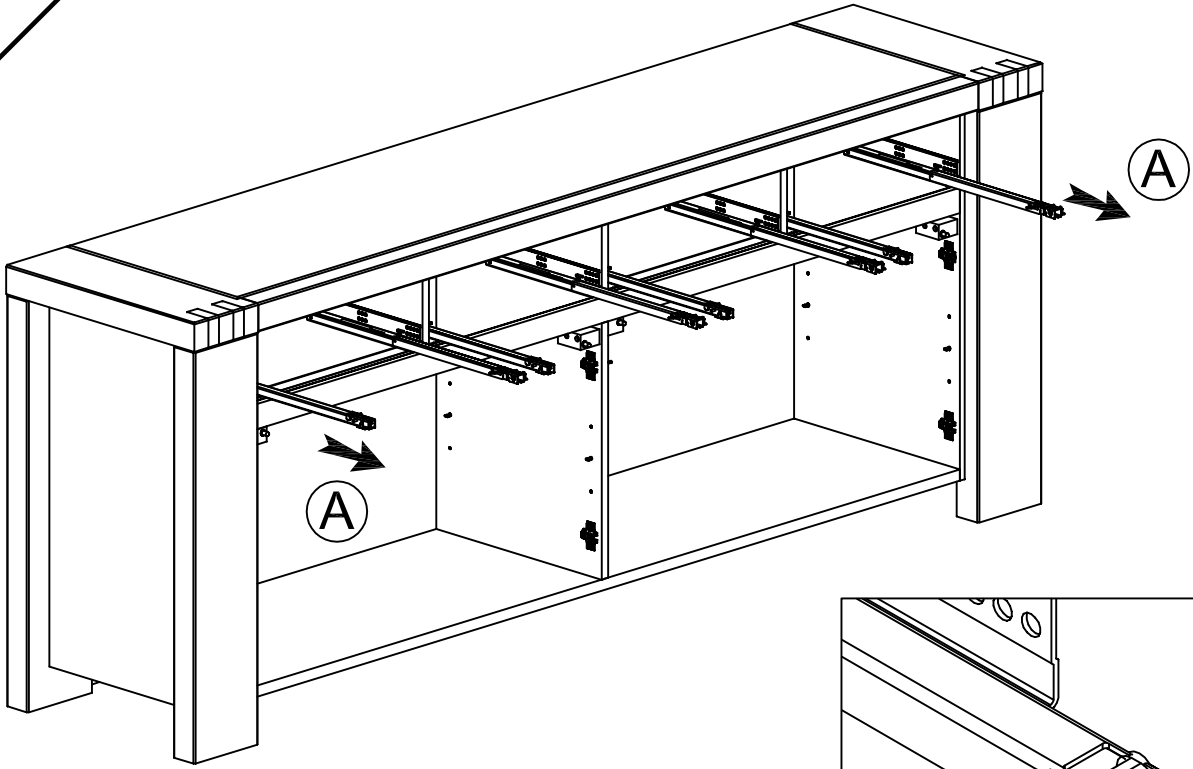

51

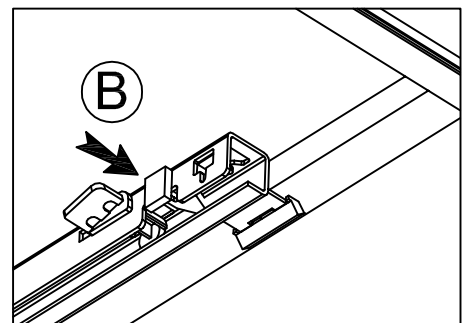
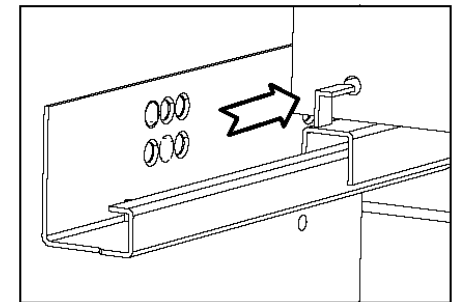
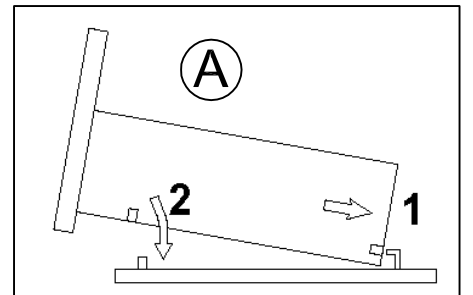
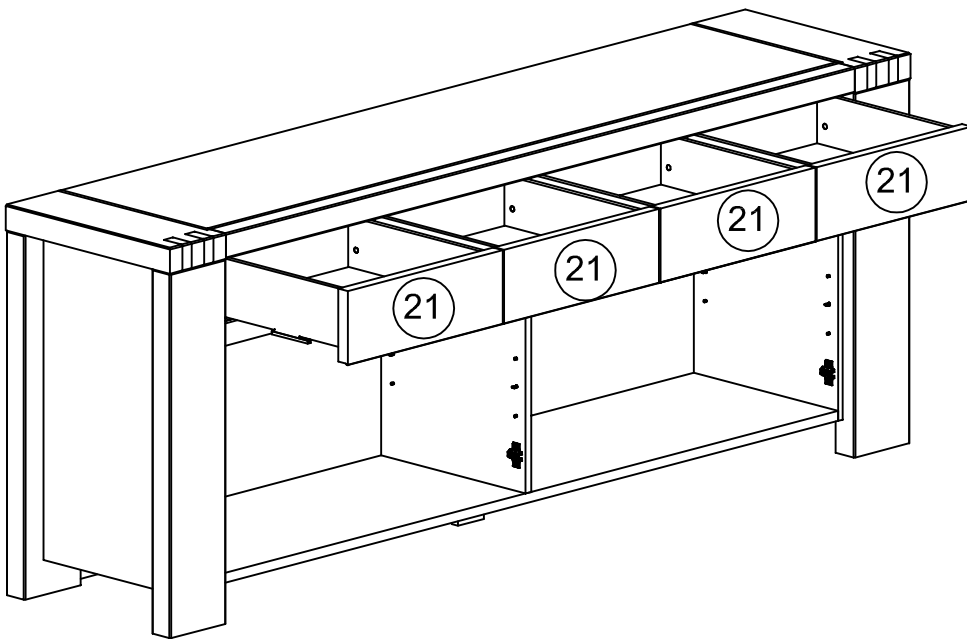

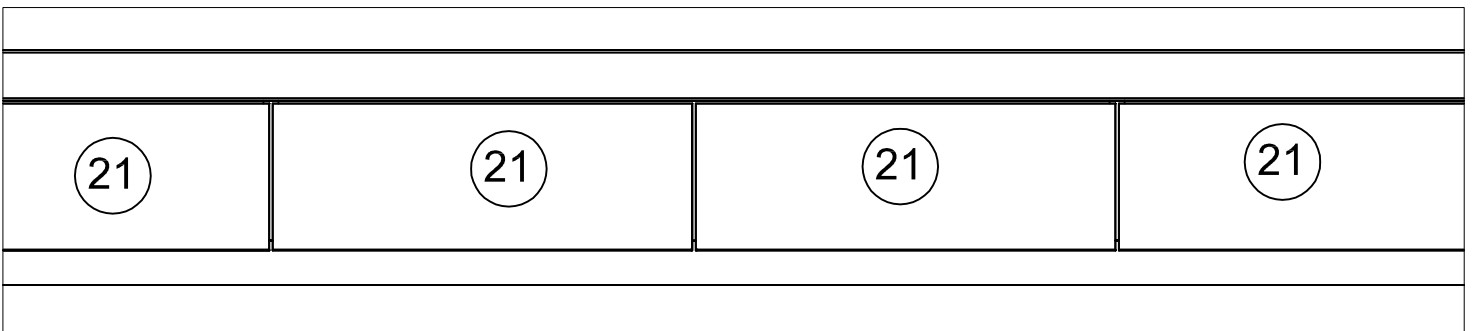
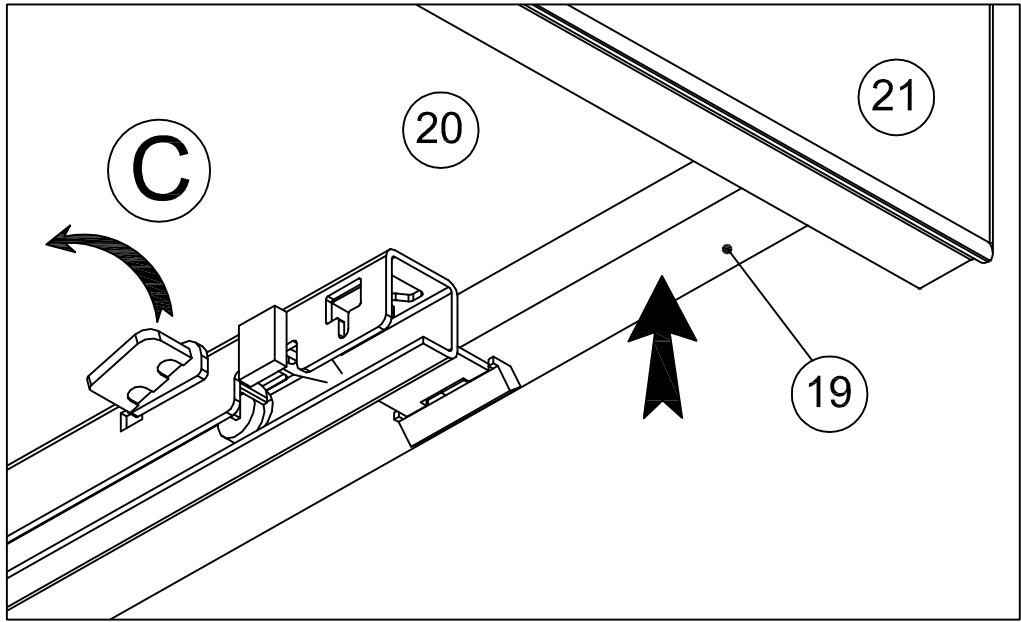
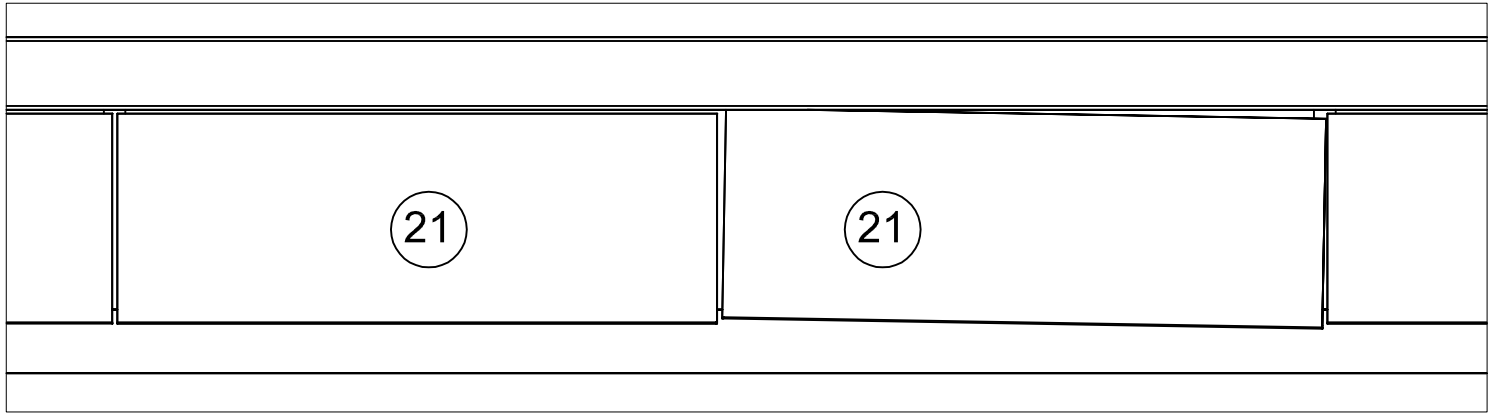

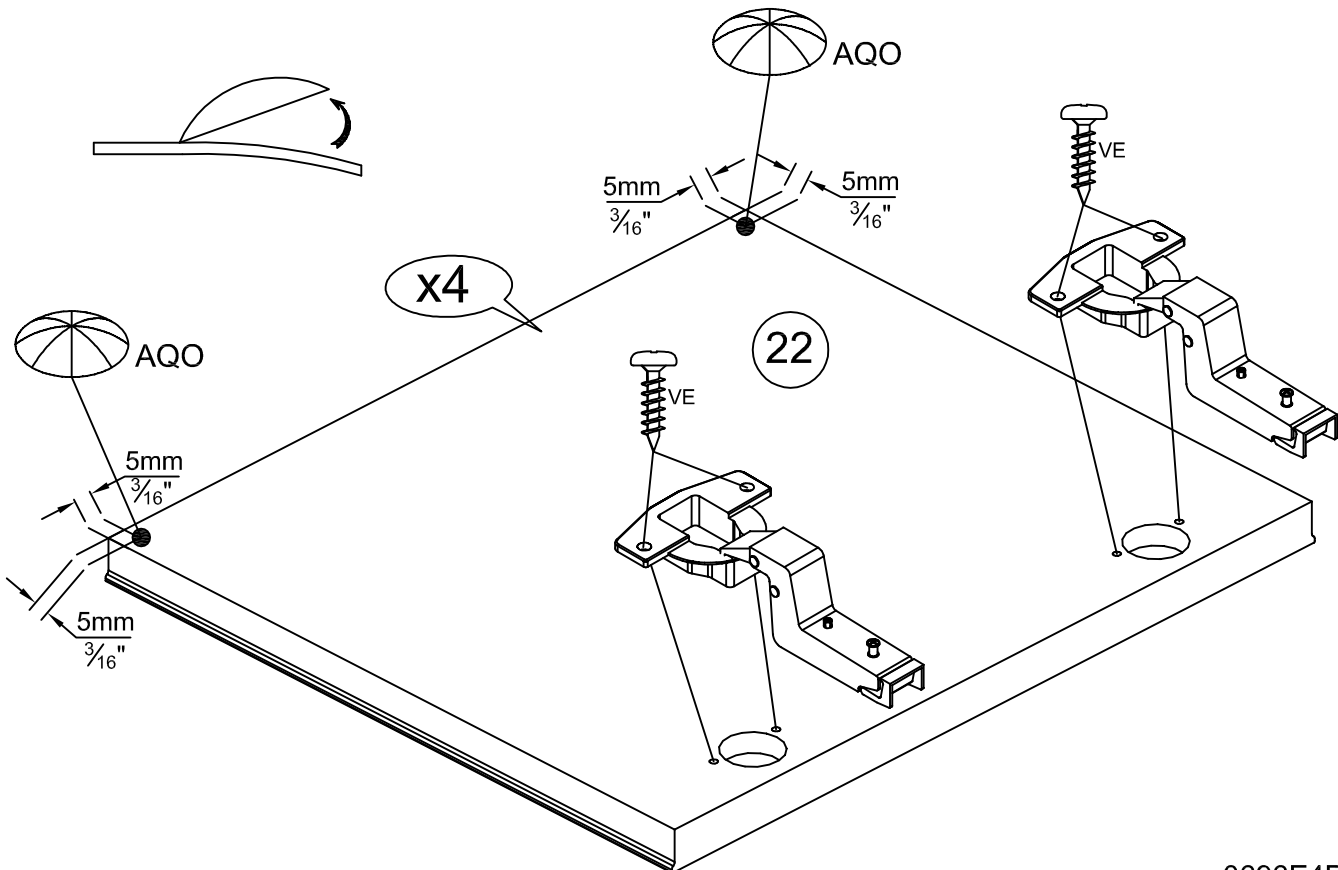
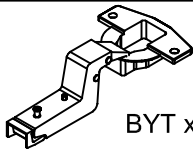
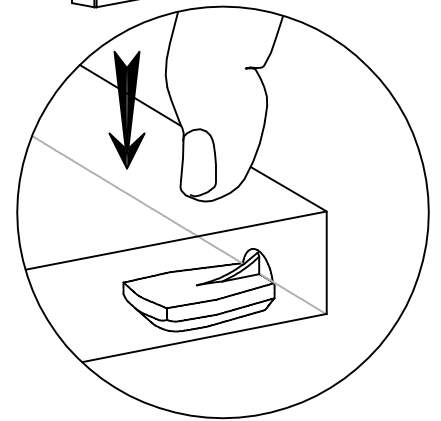
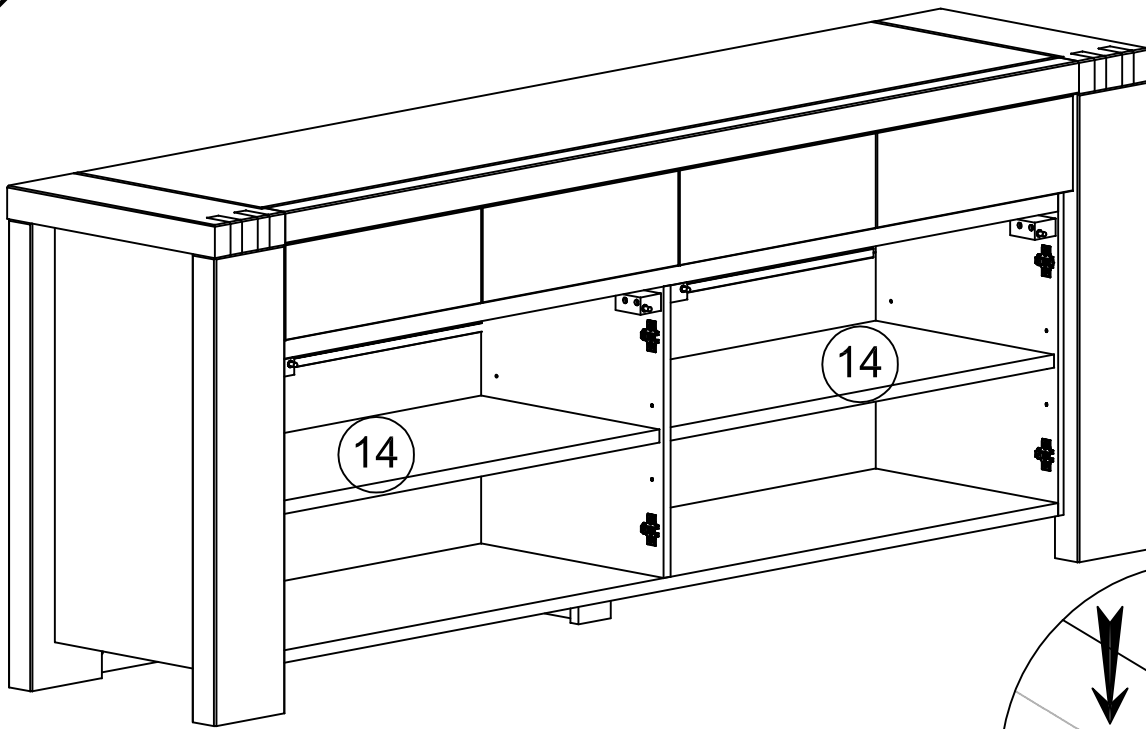

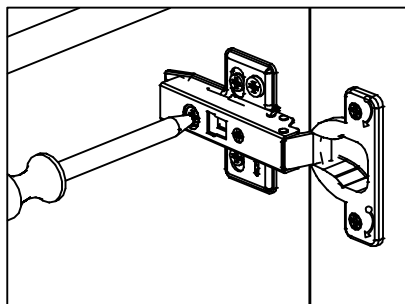
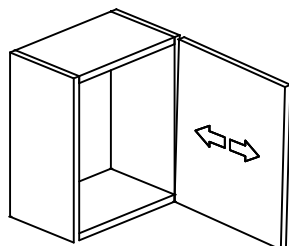
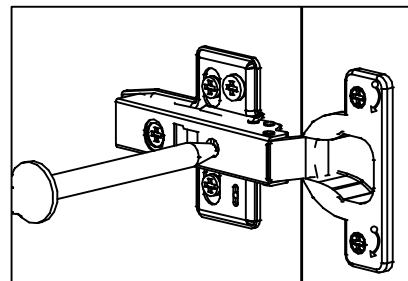
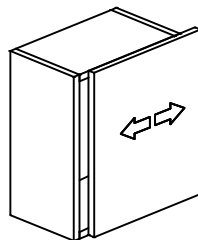
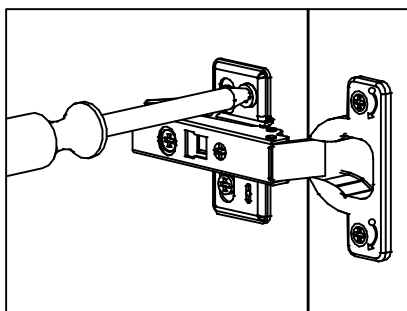
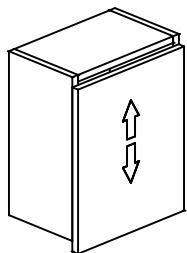
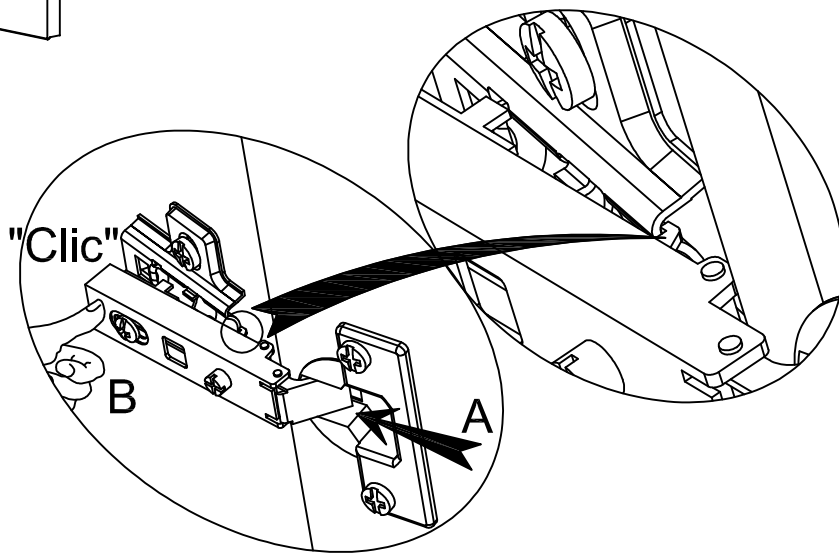
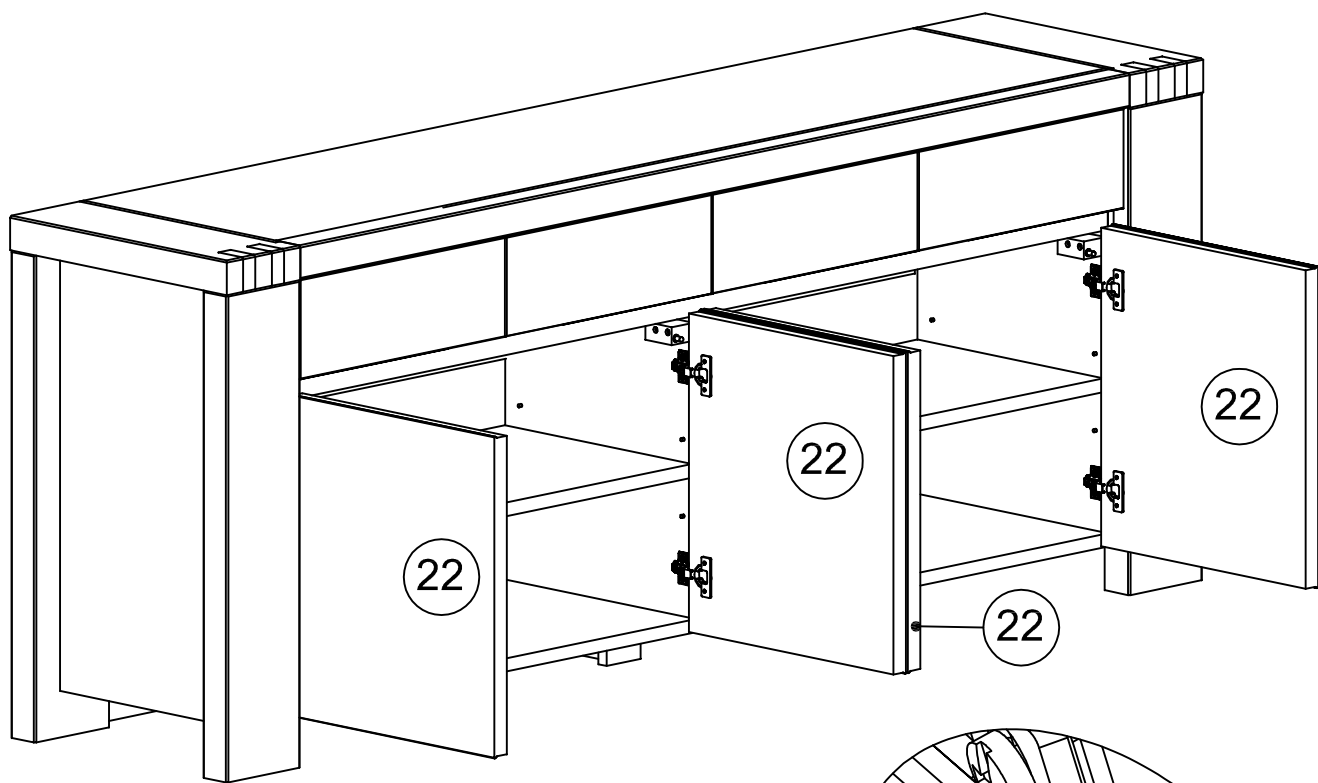

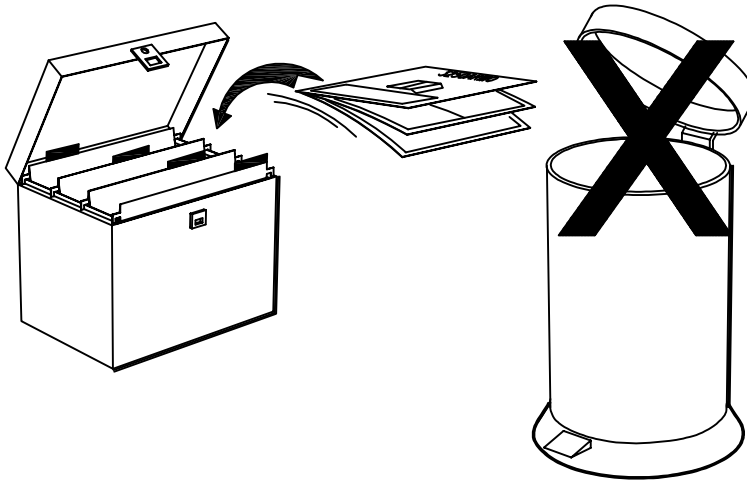
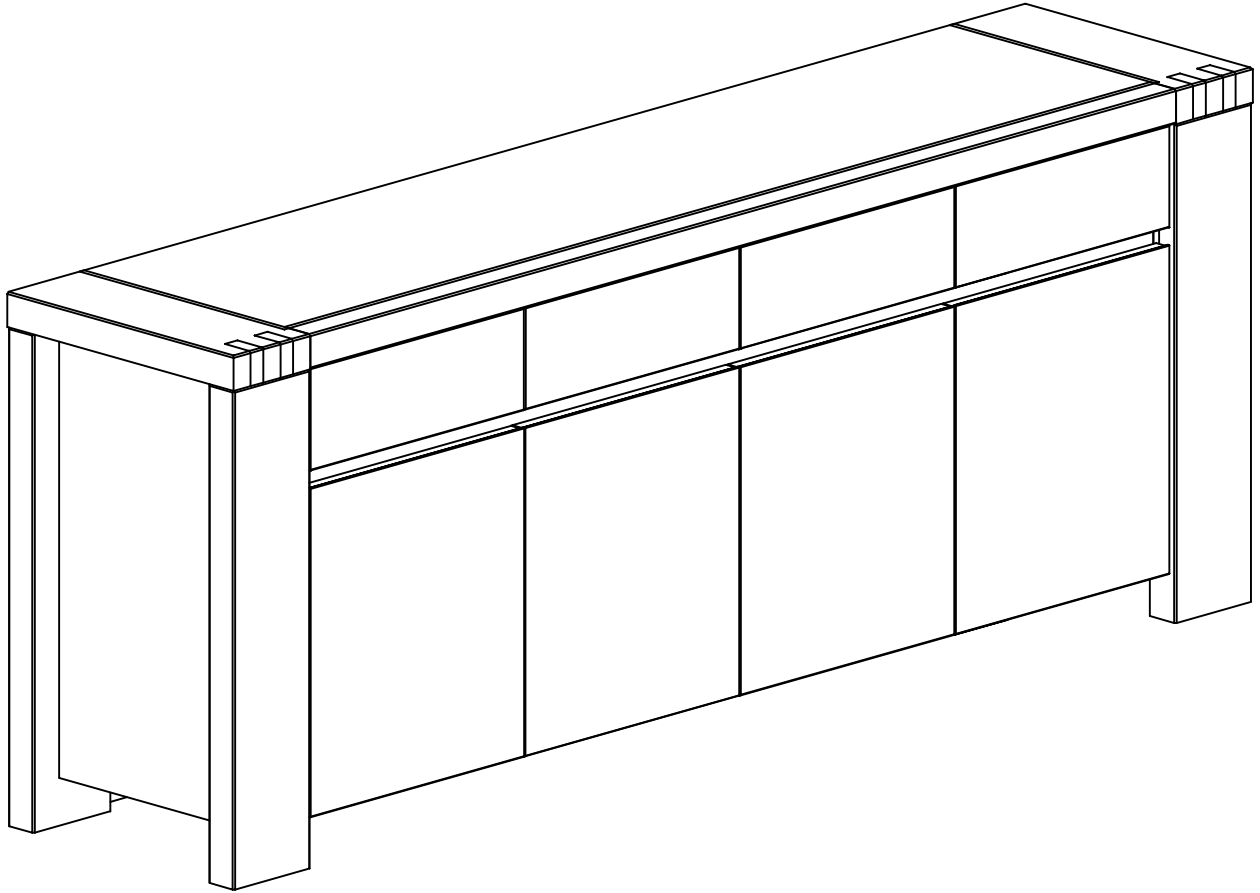

Faites un geste pour l'environnement en triant vos déchets d'emballage  
Make a gesture for the environment by sorting out your waste of packaging  
Machen Sie eine Bewegung für die Umwelt, ihre Verpackungsabfälle sortierend  
Haga un gesto para el medio ambiente escogiendo sus residuos de embalaje

## Conseils d'usage sur un meuble vernis.

Félicitations pour l'achat de votre meuble.

Ce meuble est fabriqué avec soin en placage chêne/hêtre plus quelques parties massives chêne/hêtre. Le chêne et le hêtre sont des bois de feuillu résistant et appréciés depuis des générations dans nos intérieurs (une structure de bois toute en finesse et des nuances de teintes).

Caractéristiques :

Le bois utilisé pour votre meuble est un produit naturel et unique qui est travaillé directement dans son pays d'origine après une sélection rigoureuse. Chaque meuble est unique et a ses caractéristiques car aucun morceau de bois n'a la même couleur ni la même structure. Il est même possible que vous ayez des nuances de teintes sur un même meuble. Des fissures, inégalités, ainsi que de petits ou de gros nœuds sont le résultat d'une croissance sur plusieurs années et de propriétés de l'arbre. Des différences de couleur entre les meubles et celles du magasin, ne sont pas exclues (dû à l'éclairage, au soleil, etc.)

Un vernis a été appliqué sur votre meuble. Ce vernis forme la meilleure protection possible pour le bois. Le traitement par ce vernis accentue le contraste du bois.

Entretien :

Pour l'entretien régulier de votre meuble, utiliser un chiffon doux. Si nécessaire, utilisez un chiffon humide, mais pensez à essuyer l'excédant d'eau. Si vous souhaitez utiliser un produit d'entretien, demandez conseil auprès de votre revendeur.

Recommandations :

Resserrez les vis et les assemblages après quelques temps d'usage (lit, table, bureau, charnières).

Afin de prévenir d'inutiles pressions sur les points d'attache, nous vous recommandons de placer vos meubles sur une surface plane.

Si vous souhaitez déplacer votre meuble, pensez à le vider et enlever les tablettes verres. Sans cela, vous pourriez abîmer le meuble et le sol.

Si vous posez des casseroles, cafetières, tasses, etc. nous vous recommandons d'utiliser des dessous de plats. Si vous renversez un liquide, utiliser immédiatement un chiffon sec pour essuyer la surface jusqu'à ce qu'elle soit entièrement sèche.

Il peut arriver que l'odeur caractéristique du bois reste quelques temps. Cette odeur s'estompe rapidement après 1 à 2 semaines. Aérer la pièce régulièrement accélérera le processus.

Recommandations spécifiques pour les meubles hauts :

Pour des raisons de sécurité, tous les meubles hauts disposent d'un dispositif d'accrochage au mur, disponible à l'intérieur de votre colis. Si tel n'est pas le cas, veuillez en faire la demande auprès de votre revendeur. Cela empêche toute chute accidentelle du meuble.

La qualité de nos produits et votre entière satisfaction, font l'objet de toute notre attention. En cas de questions ou de remarques, n'hésitez pas à en faire part à votre revendeur.

Nous espérons que ce meuble vous apportera entière satisfaction.