

GB - Lower Kitchen cabinet
D - Unteres Kuchenelement
E - Elemento bajo de cocina

P - Elemento de cozinha inferior
I - Mobile base da cucina
NL - Onderkastje keuken

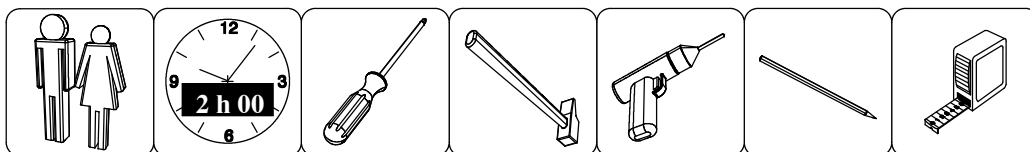

AVERTISSEMENT . Cette notice est destinée à repérer les pièces et à faciliter le montage du meuble et ne peut en aucun cas être contractuelle, en effet les caractéristiques du produit sont susceptibles d'être modifiées sans préavis par le fabricant afin d'en améliorer la qualité.



GB - IMPORTANT. These instructions are to be used to identify the parts and facilitate furniture assembly and are in no case binding. Product characteristics are subject to change without notice from the manufacturer to improve quality.

D - HINWEIS. Diese Anleitung dient nur zum Erkennen der Teile und zur Erleichterung der Montage des Möbels und ist keinesfalls verbindlich, da die Merkmale des Produkts ohne Vorbehalt des Herstellers geändert werden können, um ihre Qualität zu verbessern.

E - ADVERTENCIA: este folleto explicativo está destinado a identificar las piezas y facilitar el montaje del mueble, en ningún caso podrá ser considerado como un contrato. El fabricante puede modificar las características del producto sin previo aviso para mejorar su calidad.

P - AVISO : Este folheto destina-se a identificar as peças e a facilitar a montagem do móvel e não pode, de modo algum, ser contratual. De facto, as características do produto podem ser modificadas sem aviso prévio pelo fabricante para melhorar a sua qualidade.

I - AVVERTENZA - Queste istruzioni sono destinate a distinguere i pezzi e a facilitare il montaggio del mobile e non sono in nessun caso contrattuali; le caratteristiche del prodotto sono infatti soggette a modifiche senza preavviso da parte del costruttore al fine di migliorarne la qualità.

NL - WAARSCHUWING. Deze handleiding is bedoeld om de verschillende onderdelen te herkennen en het monteren van de meubels te vergemakkelijken en is in geen geval bindend, daar zonder voorafgaand bericht van de fabrikant de eigenschappen van het product gewijzigd kunnen worden, teneinde de kwaliteit hiervan te verbeteren.

Pose de l'autocollant :

- décoller la protection
- le positionner sur la porte grise
- maroufler les lettres
- tirer le film transparent doucement.

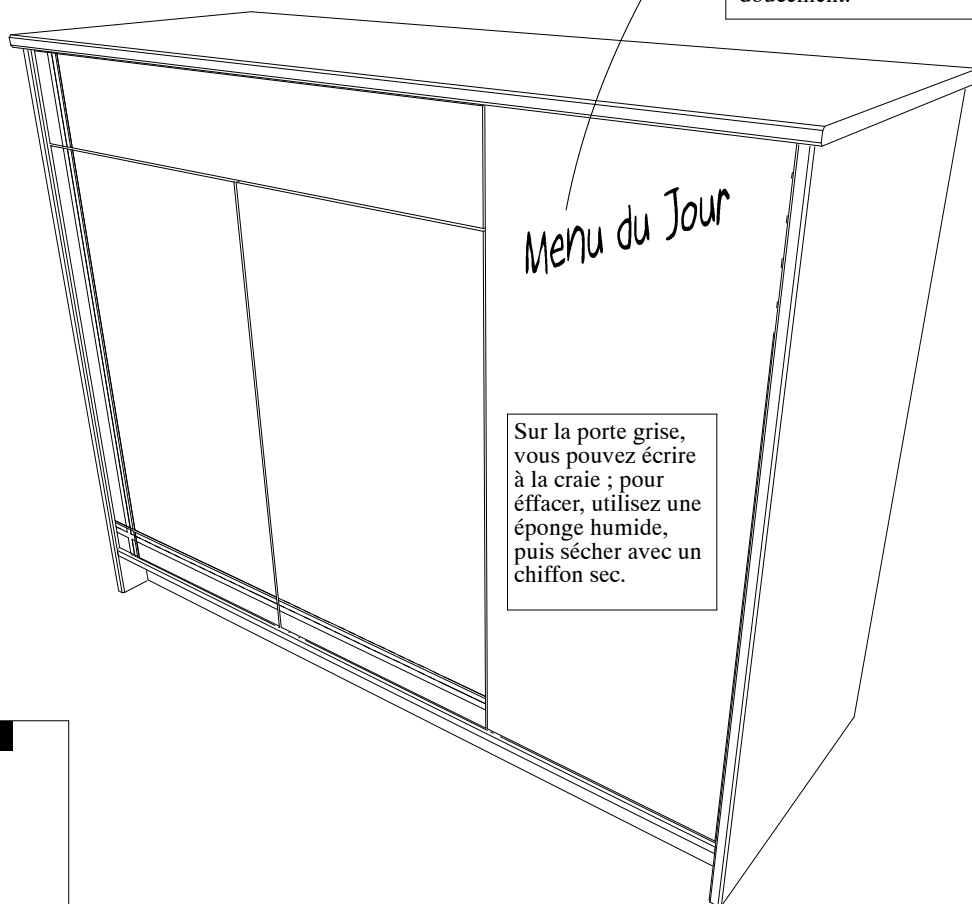

BISTROT COMBINE 116 CM

Code EAN : 3170720578312
Code article : 41.291.804602.00.0
Structure : panneaux de particules blanc
Facade : panneaux de particules
Chants : décor aluminium
Finition : décor blanc + gris ardoise
Poignées : aluminium mat

0 1 cm 2 3 4 5 0 1 cm 2

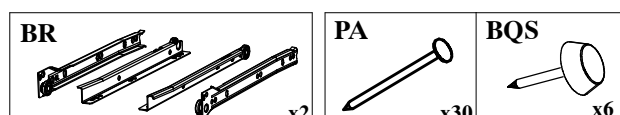
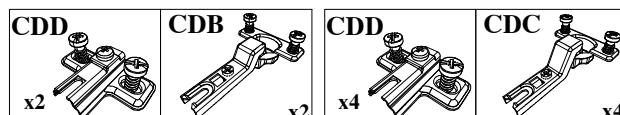
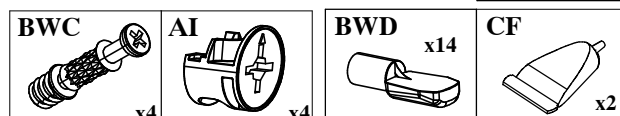
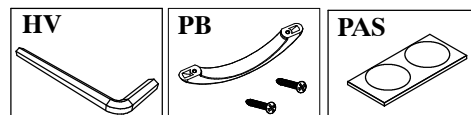
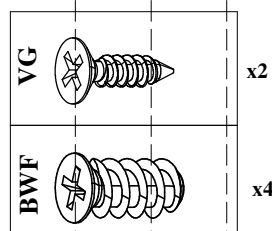
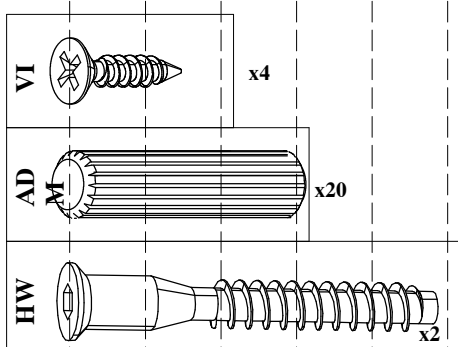

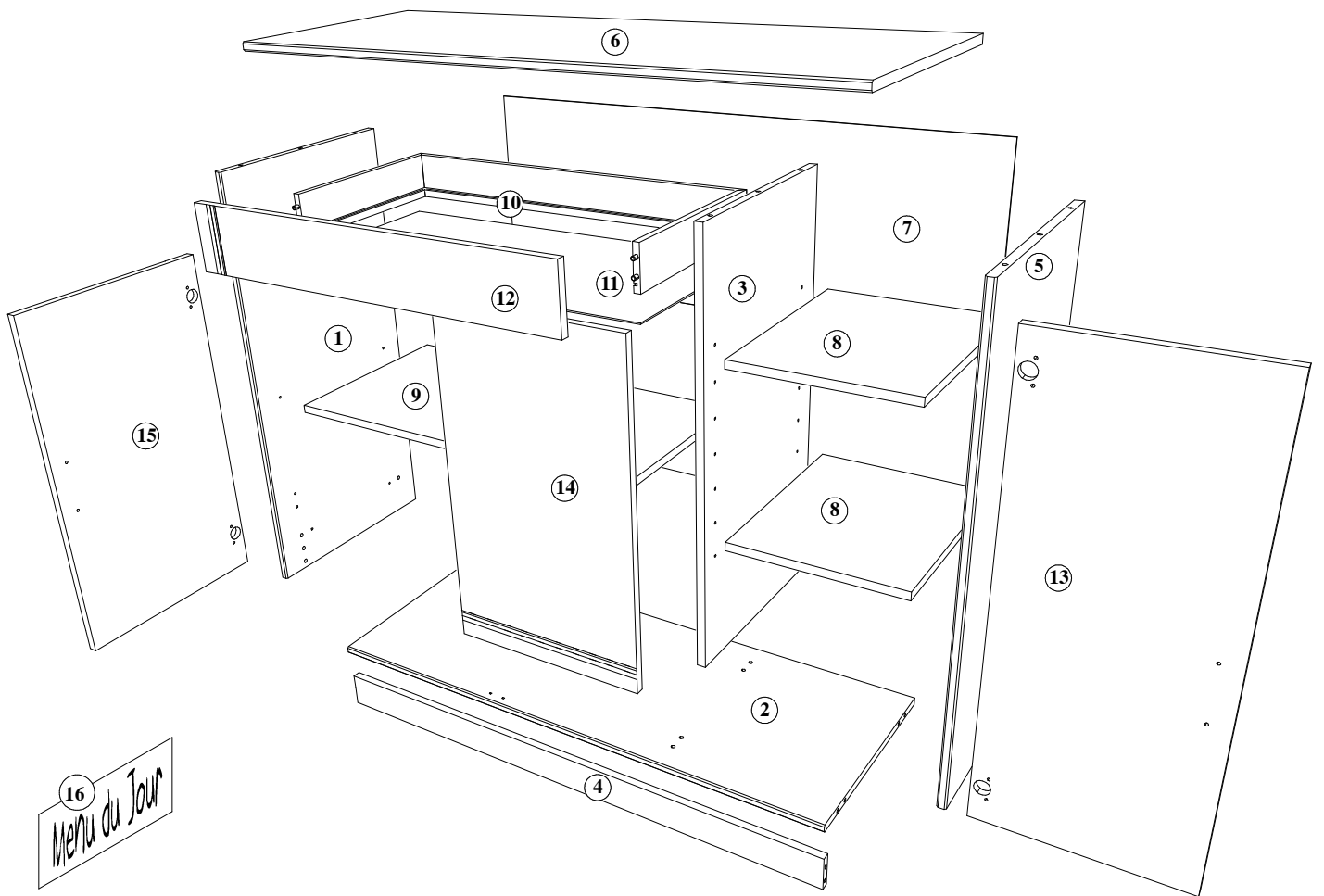

ne pas mélanger les sachets entre eux.

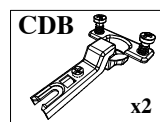
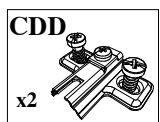
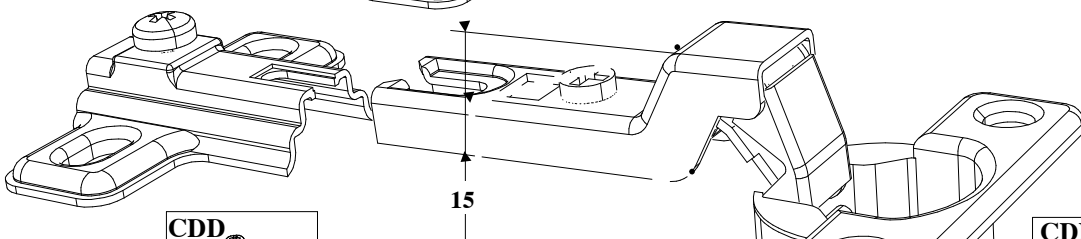
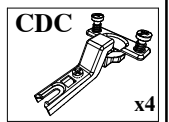
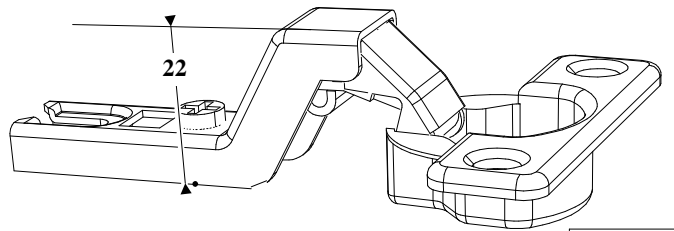
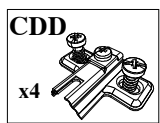

1



BR

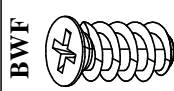
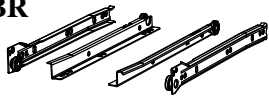

BWC



CDD

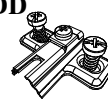

CF



VG

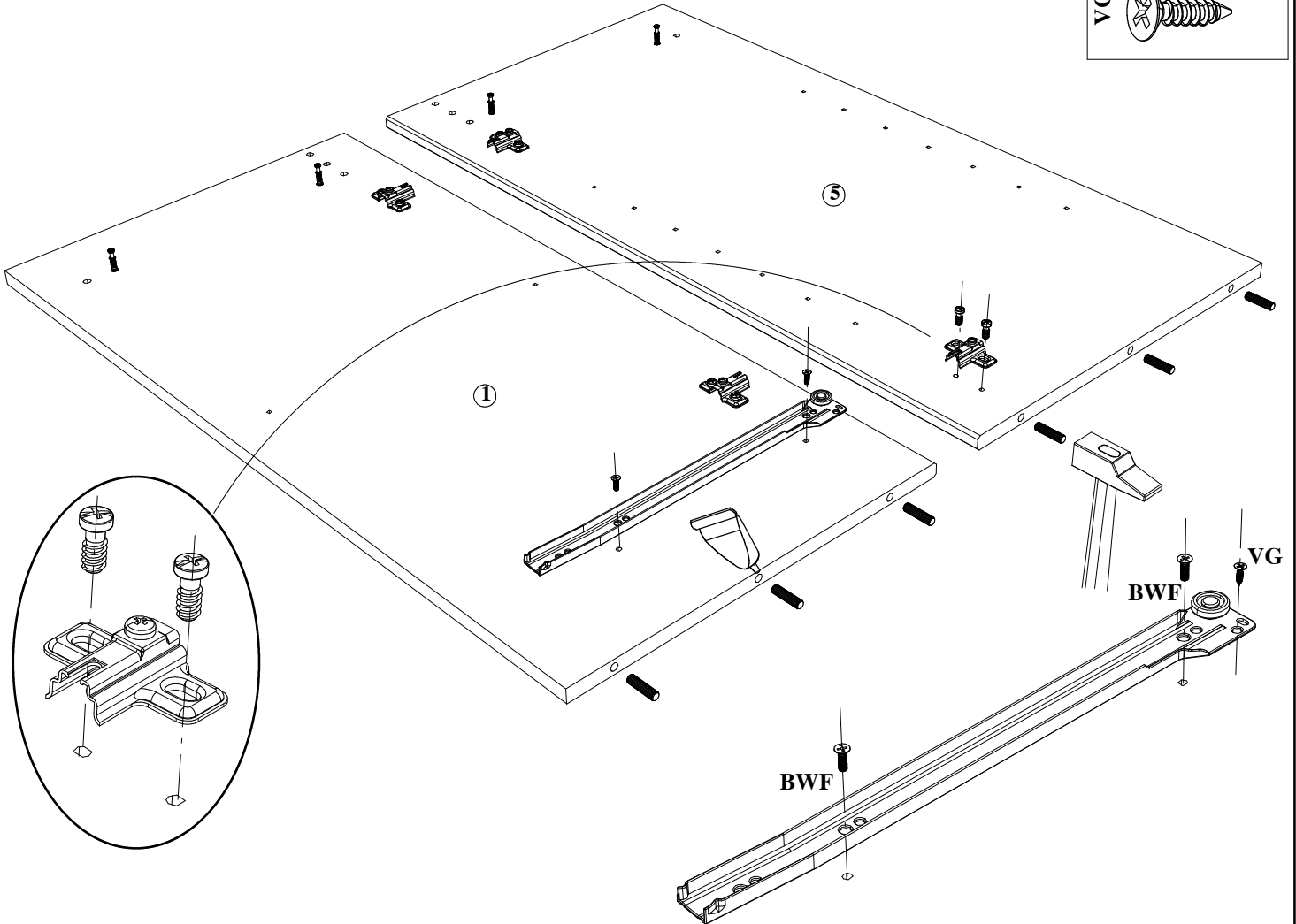
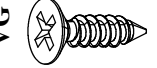

2

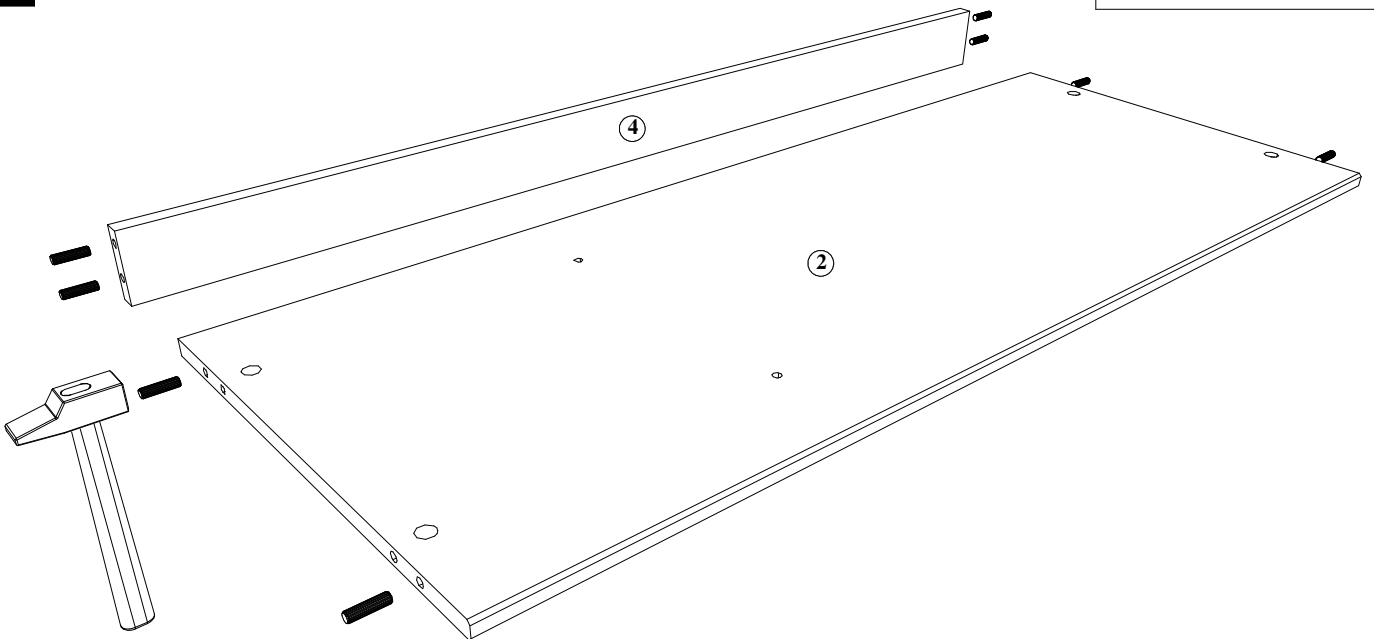
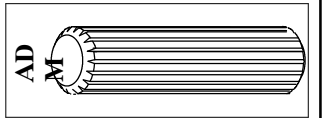

3

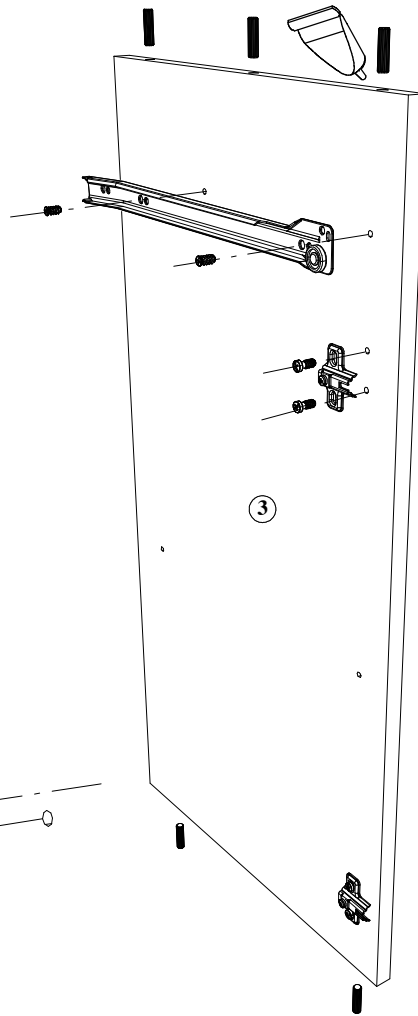
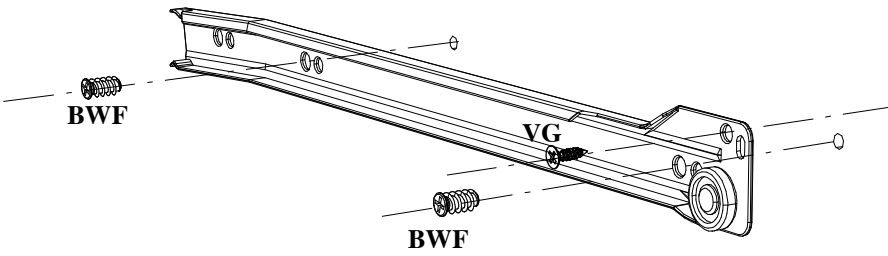
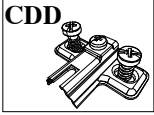
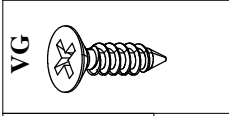
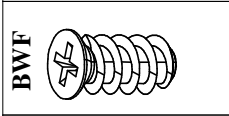
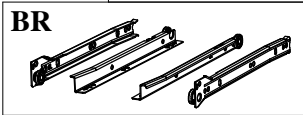
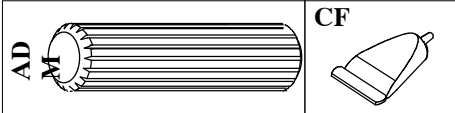

4

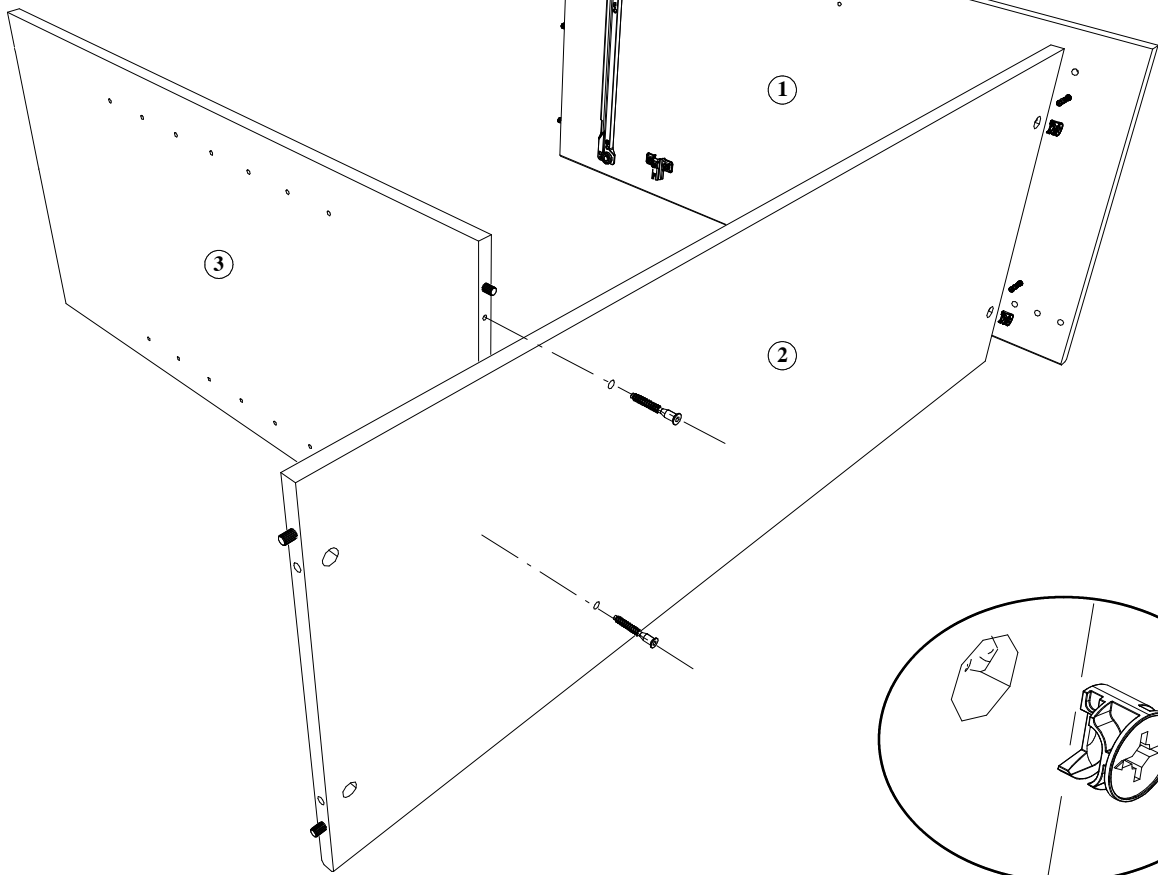
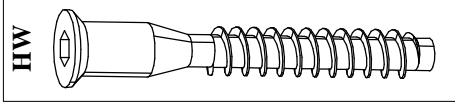

5

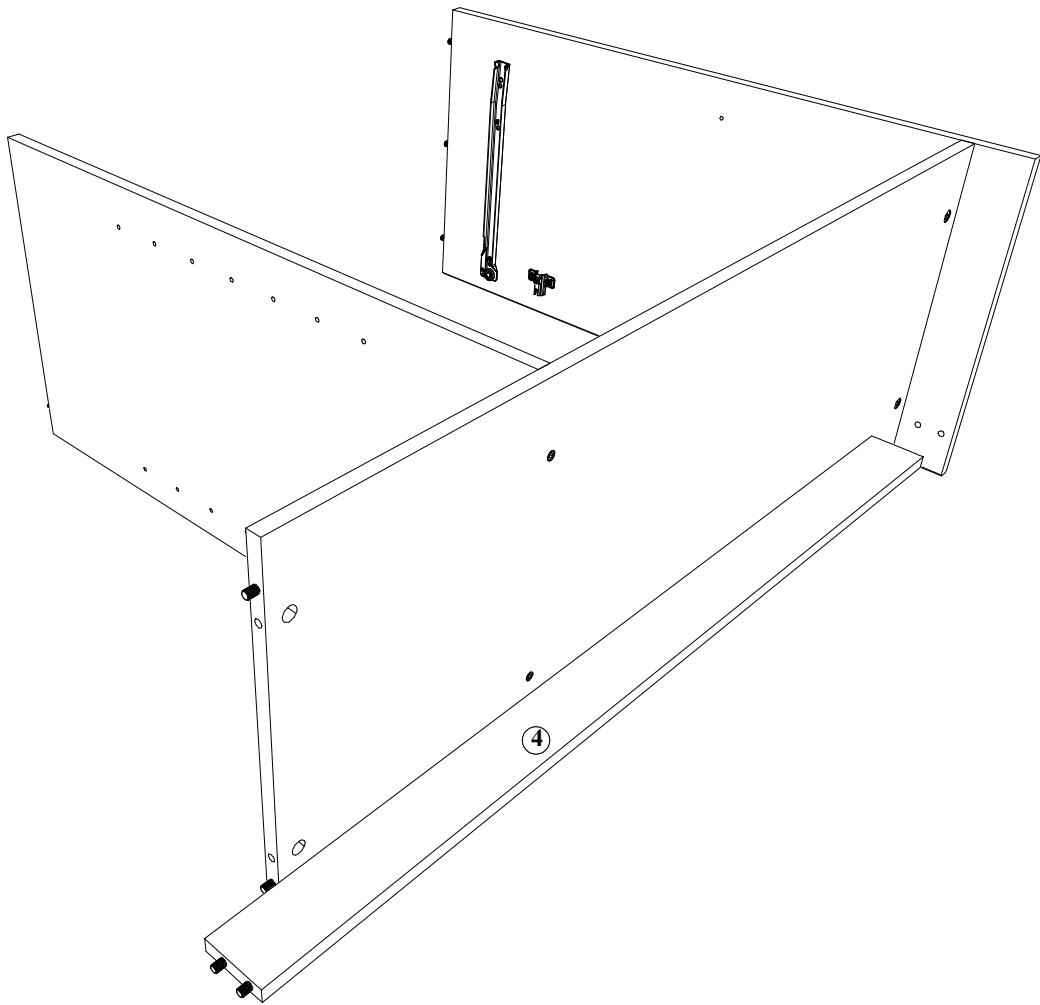

6

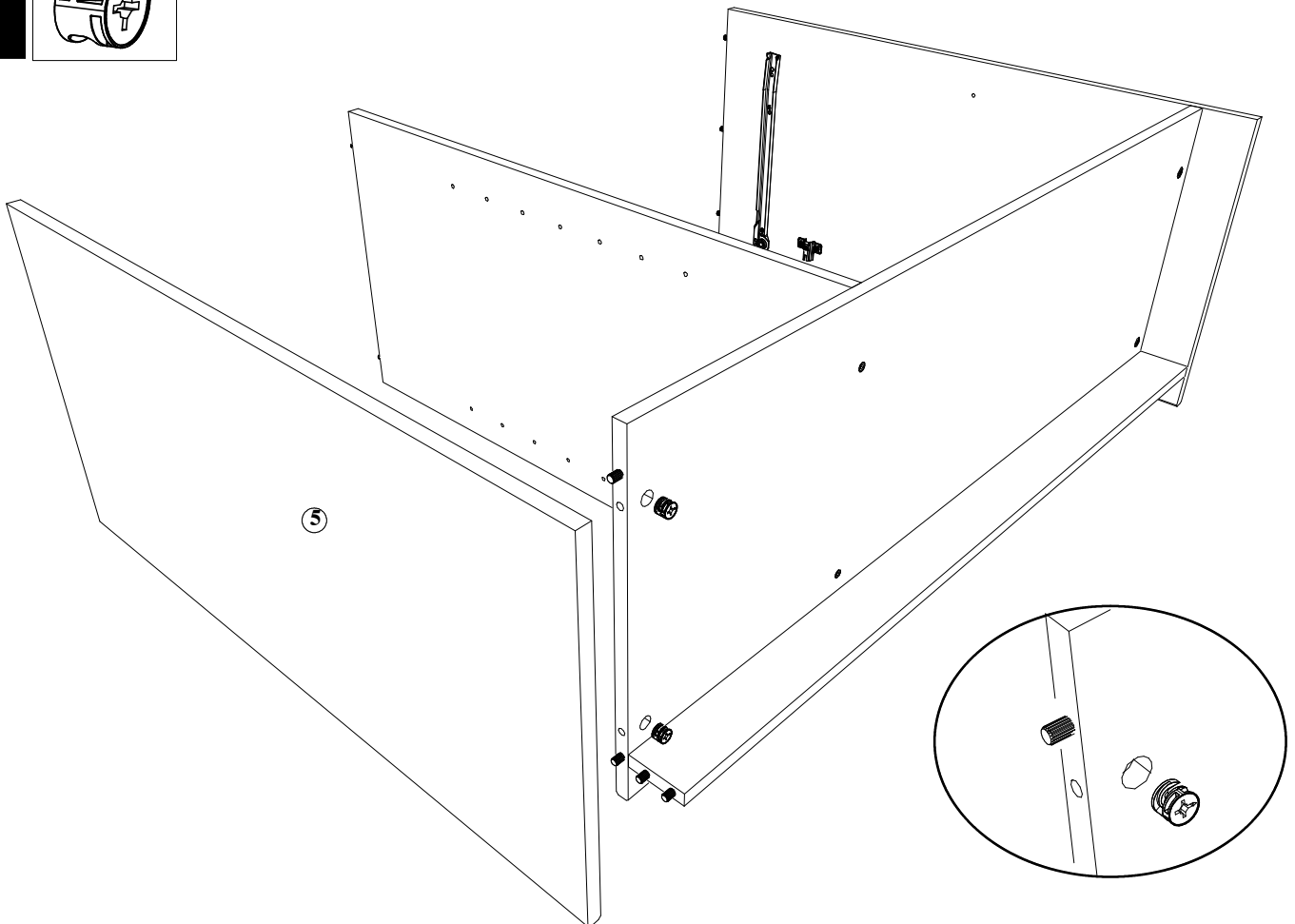

7

CF

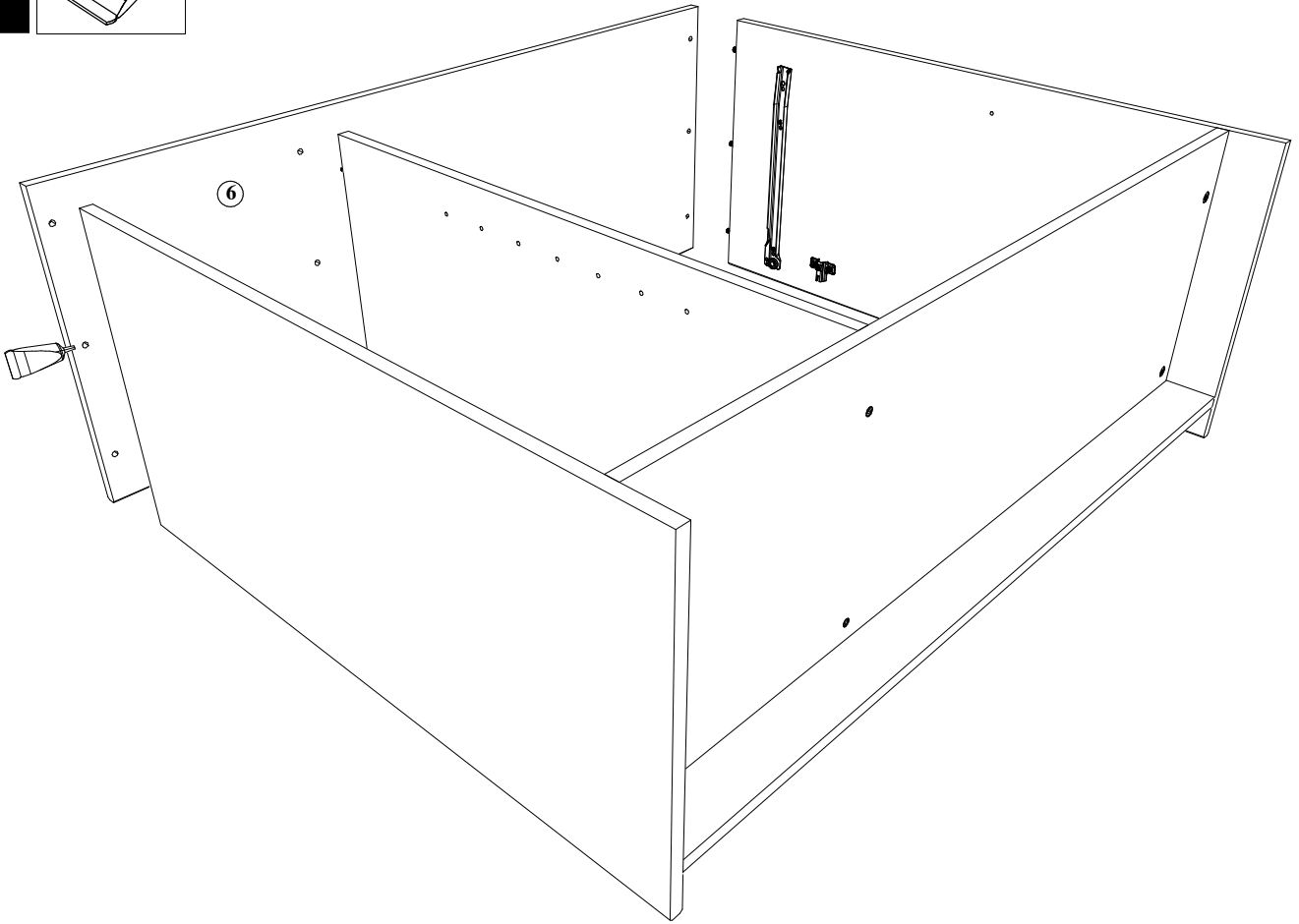
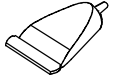

8

PA

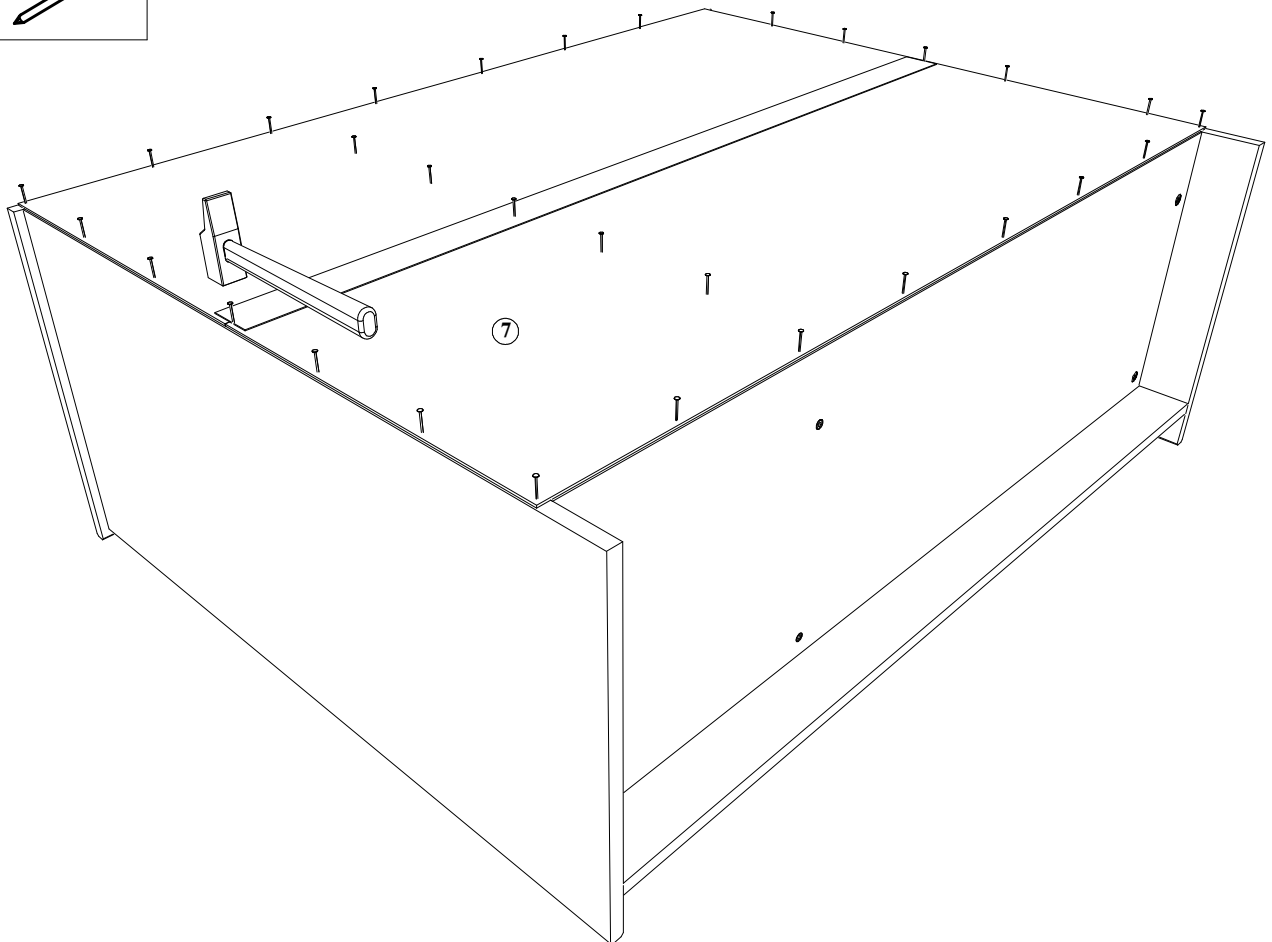

9

BQS

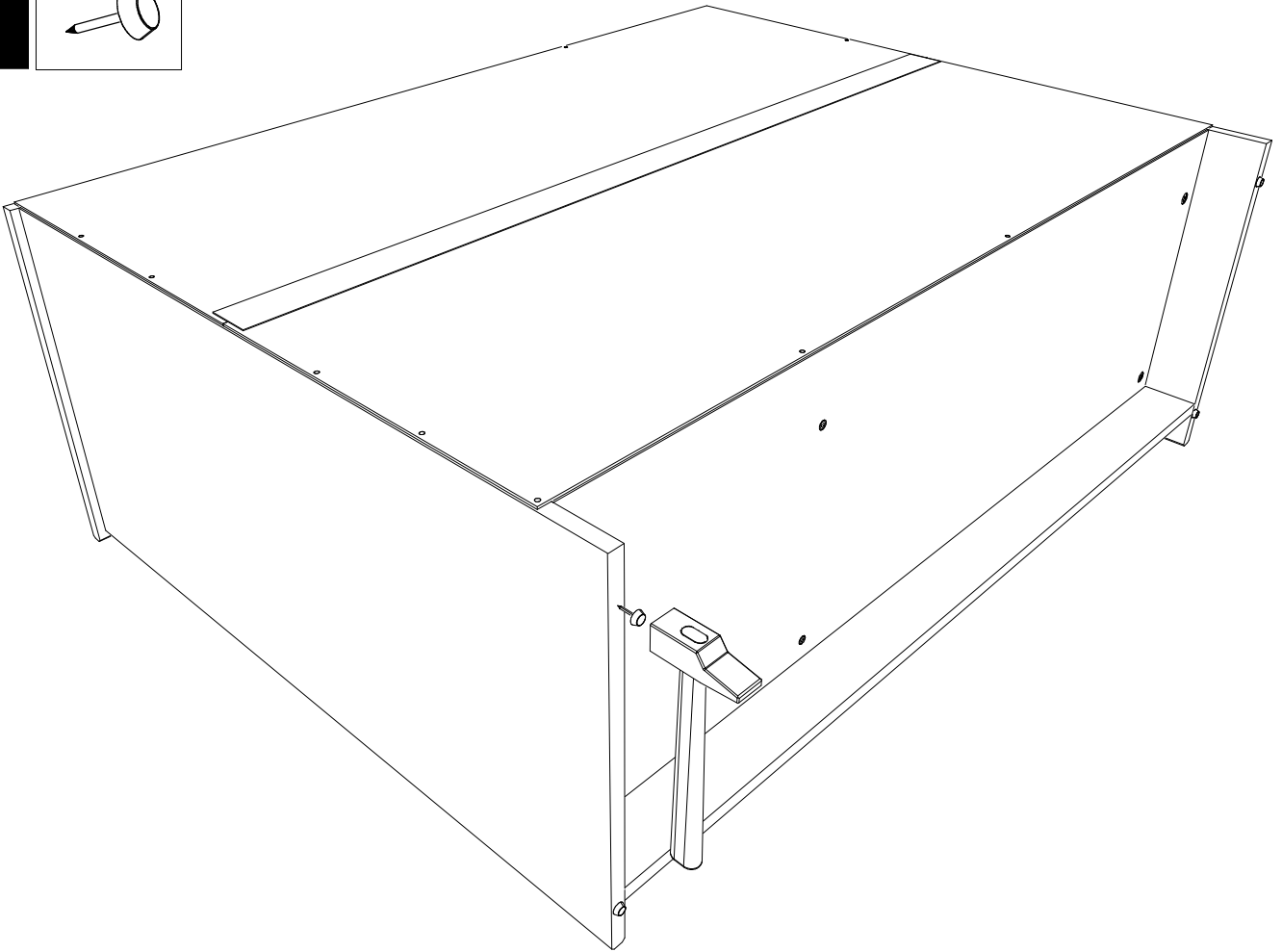

10

CF

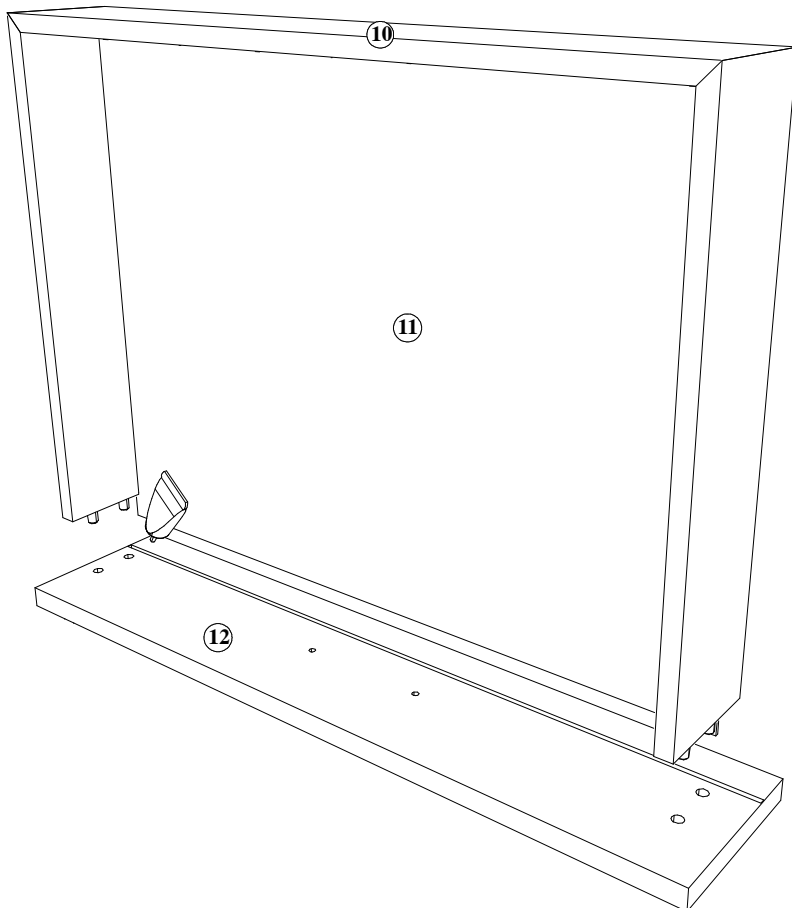
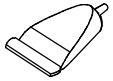

11

BR

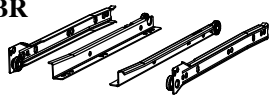

VI

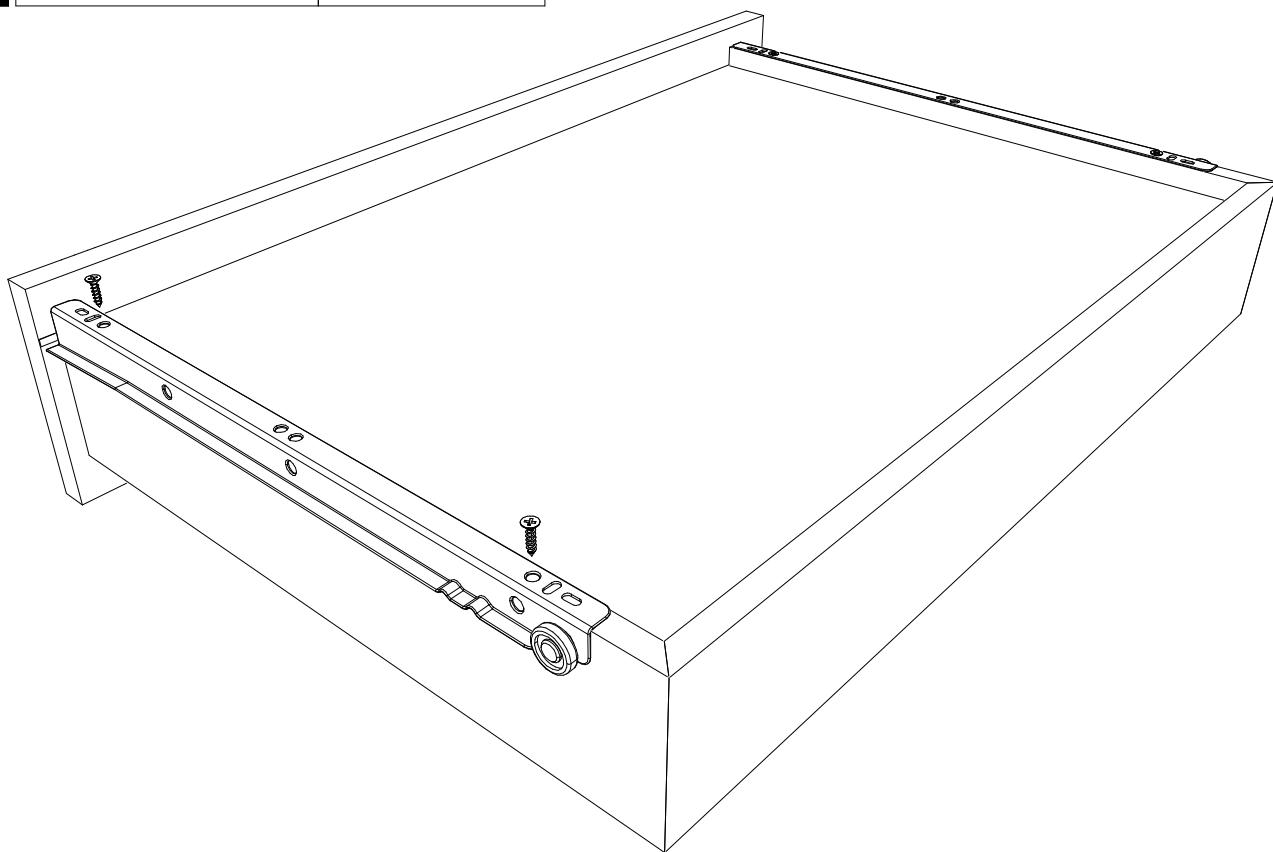
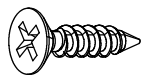

12

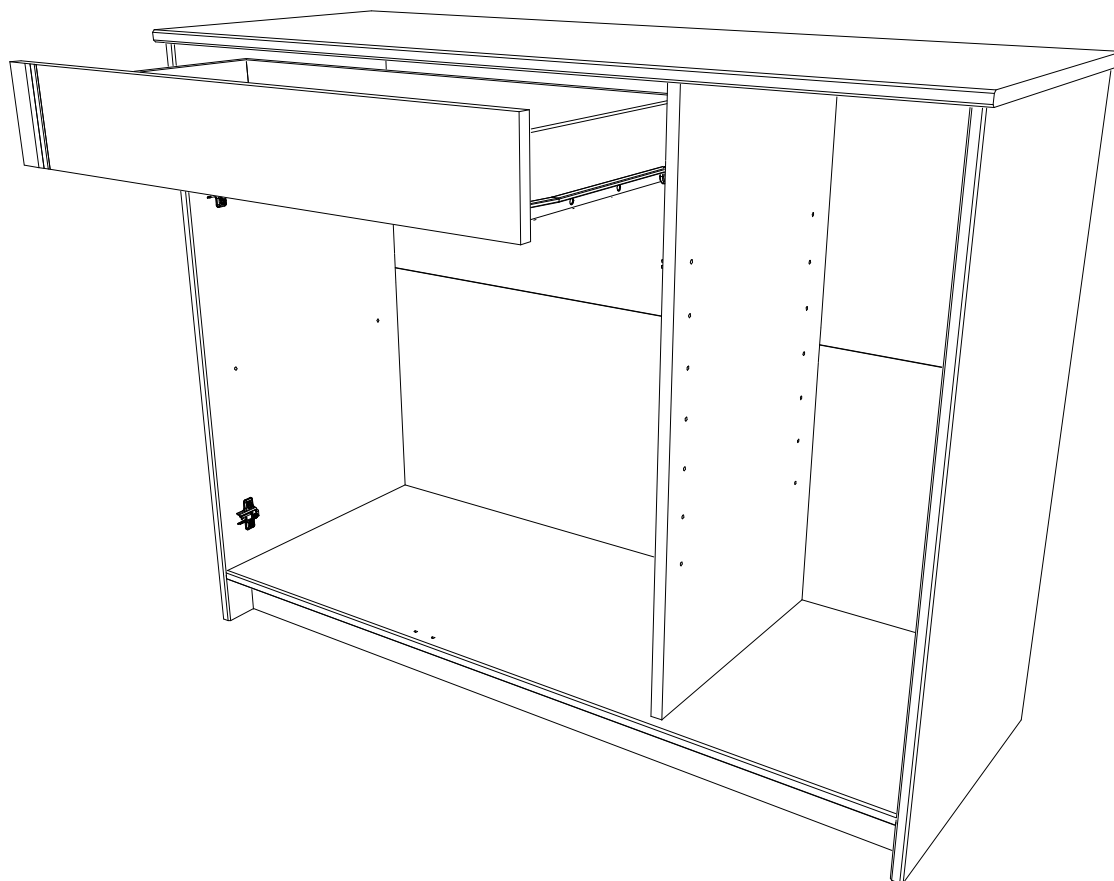

13

BWD

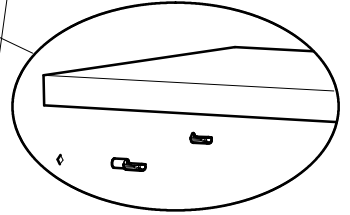
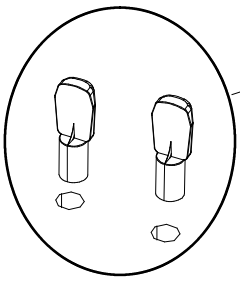
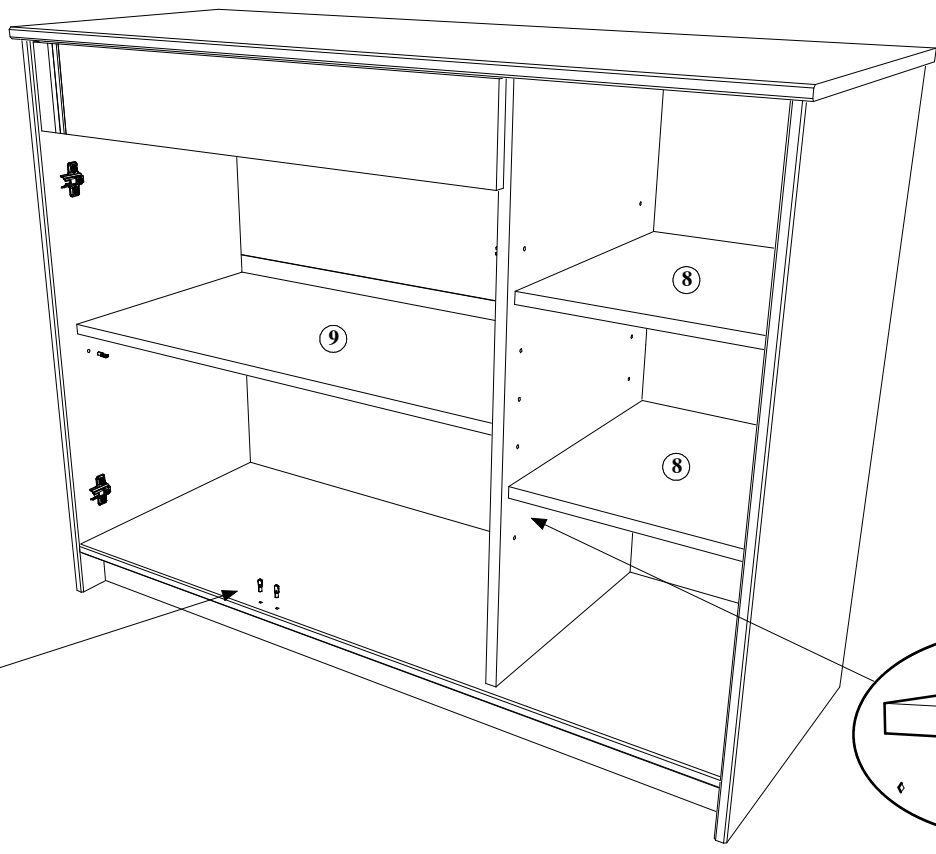
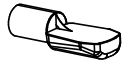

14

CDB

CDC

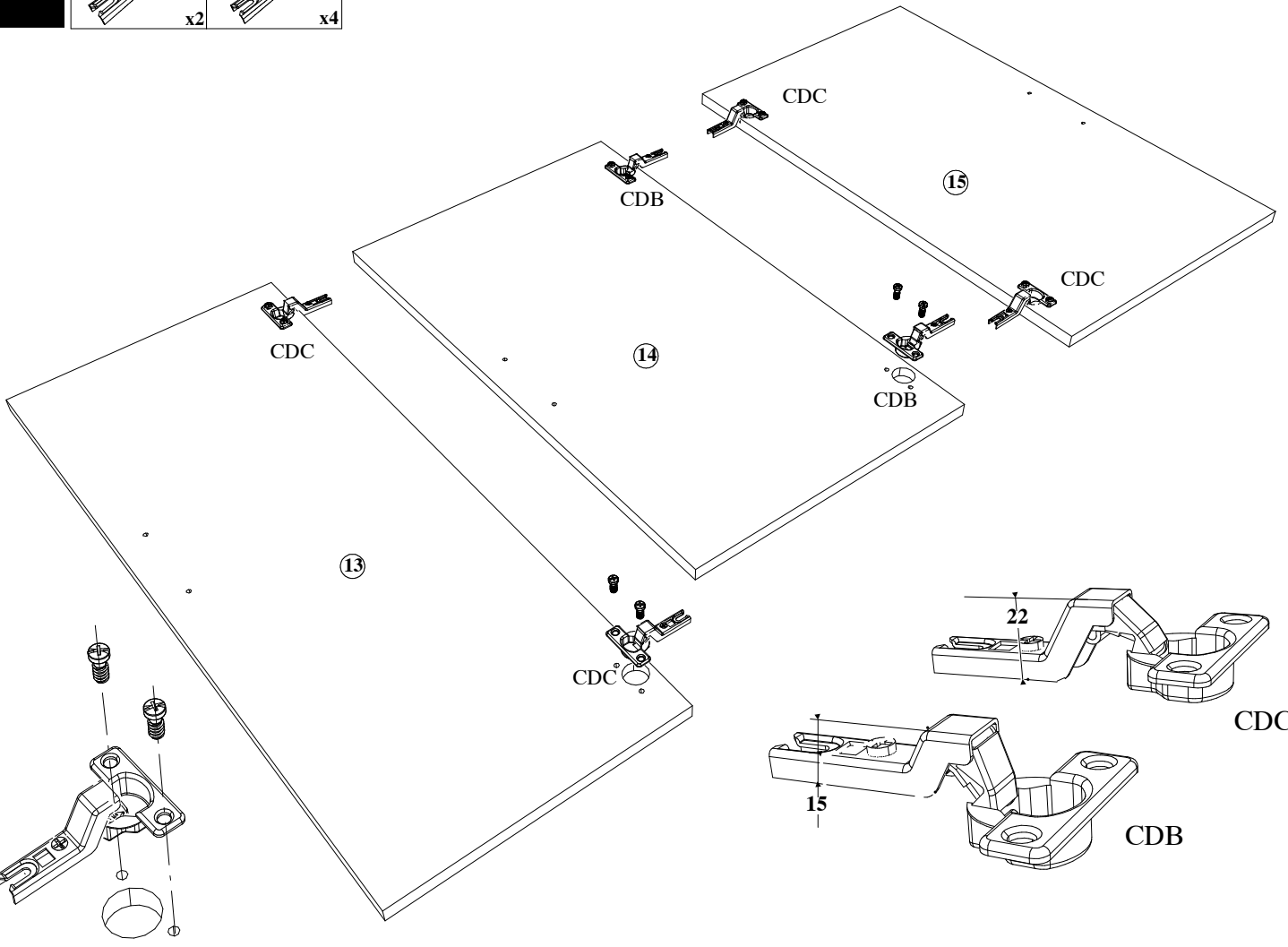
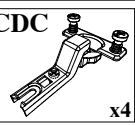
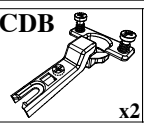

15

POSE DES POIGNEES OU BOUTONS

Déboucher le ou les perçages sur la porte si nécessaire après vérification du sens d'ouverture.
Utiliser une chute de bois pour éviter les éclats.
Vérifier la longueur de la vis.

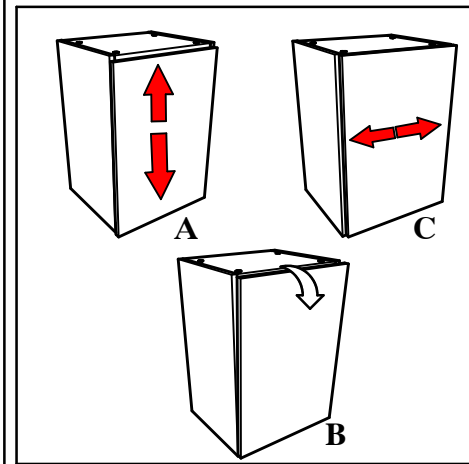
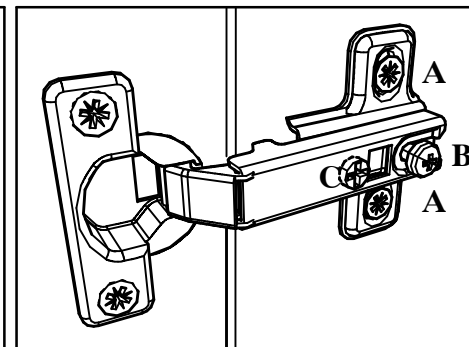
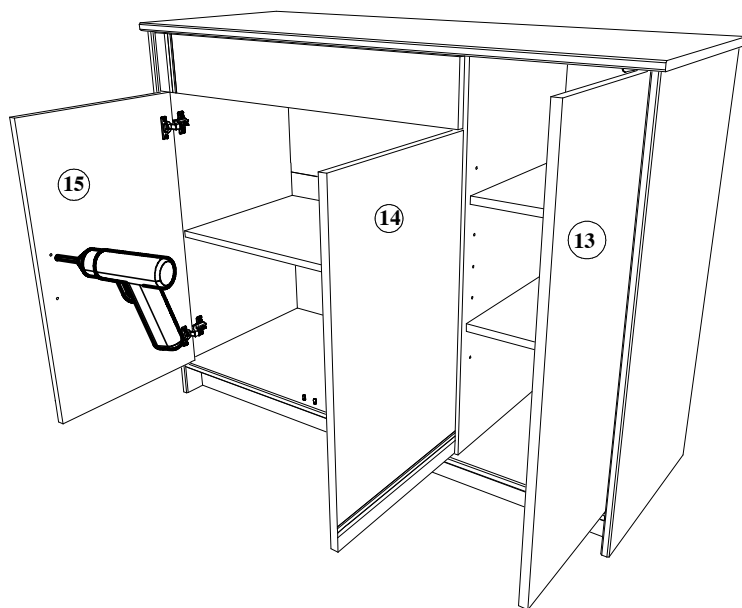

GB - FIXING THE HANDLES OR KNOBS

Unplug the hole(s) on the door as necessary after checking the direction in which it opens.
Unplug the hole with a piece of scrap wood to avoid splintering the surround.
Check the length of the screw.

D - ANBRINGEN DER GRIFFE ODER KNÖPFE

Wenn erforderlich, die Bohrung(en) in der Tür freimachen, nachdem Sie die Öffnungsrichtung überprüft haben.
Einen Holzabfall verwenden, um Splitter zu vermeiden.
Die Schraubenlänge prüfen.

E - COLOCACIÓN DE TIRADORES

De ser necesario, destapar la(s) perforación(ones) de la puerta tras verificar el sentido de apertura.
Utilizar una caída de madera para evitar las astillas.
Verificar el largo del tornillo.

P - COLOCAÇÃO DOS PUXADORES OU BOTÕES

Abrir o ou os furos na porta se for necessário após ter verificado o sentido de abertura. Utilizar uma lasca de madeira para evitar as estilhaças.
Verificar o comprimento do parafuso.

I - POSA DELLE MANIGLIE O POMELLI

Dopo aver verificato il senso di apertura, aprire, se necessario, la o le perforazioni sulla porta.
Per evitare le schegge, usare un pezzo di legno di scarto.
Verificare la lunghezza della vite.

NL - MONTAGE DER HANDGREPEN OF KNOPPEN

Steek, nadat u de openingsrichting hebt gecontroleerd, zonnig het/de geboorde gat(en) door.
Gebruik hiervoor een stukje hout om spanen te voorkomen.
Controleer de lengte van de schroef.

SERVICE APRES-VENTE

Si malgré l'attention particulière que nous avons apportée à ce colis, son contenu ne vous donnait pas entière satisfaction, signalez au point de vente où vous avez effectué votre achat :

- * le numéro du panneau ou de la pièce de quincaillerie
- * le numéro de la notice
- * la référence du meuble figurant sur le colis

Ces trois éléments nous sont nécessaires pour vous assurer un service précis.

GB - AFTER SALES SERVICE

Despite the care taken in our packaging of this product, should its contents not meet with your complete satisfaction, please inform the sales outlet where the purchase was made indicating:

- the panel number or hardware item number
- the number on the assembly instructions sheet
- the reference of the cabinet on the package.

These three items are necessary to provide quick and precise after sales service.

D - KUNDENDIENST

Sollte der Inhalt des Pakets Sie trotz aller unserer Aufmerksamkeit nicht völlig zufriedenstellen, teilen Sie Ihrer Verkaufsstelle bitte folgende Auskünfte mit:

- Nummer der Platte oder des Beschlages
- Nummer der Anleitung
- Auf dem Paket angegebene Bestellnummer des Möbels

Wir benötigen diese drei Angaben, um einen präzisen und schnellen Kundendienst zu gewährleisten.

E - SERVICIO POSVENTA

Si a pesar de la atención particular con que hemos realizado este paquete, su contenido no le diera entera satisfacción, señalar al punto de venta donde ha hecho su compra:

- el número del panel o de la pieza de ferretería
- el número del folleto explicativo
- la referencia del mueble que figura en el paquete

Necesitamos estos tres elementos para garantizarle un servicio preciso y rápido.

P - SERVIÇO PÓS-VENDA

Se, apesar da atenção especial com que preparámos a encomenda, o seu conteúdo não lhe der inteira satisfação, comunique ao ponto de venda onde efectuou a sua compra :

- o número da tábua ou da peça metálica
- o número do folheto
- a referência do móvel indicada na embalagem

Estes três elementos são necessários para que asseguremos um serviço preciso e rápido.

I - ASSISTENZA TECNICA

Qualora, nonostante tutta la cura apportata alla confezione del collo, il contenuto dello stesso non vi desse intera soddisfazione, segnalate al punto vendita in cui avete effettuato l'acquisto:

- il numero del pannello o del pezzo di ferramenta
- il numero delle istruzioni
- la referenza del mobile riportata sul collo

Questi tre elementi sono necessari per garantire un servizio rapido e preciso.

NL - SERVICEDIENST

Indien u, ondanks de zorg die wij aan de inhoud van dit pakket hebben besteed, niet geheel tevreden bent over de inhoud, dient u de navolgende gegevens door te geven aan het verkooppunt waar u de aankoop gedaan hebt:

- het nummer van het bewuste paneel of ijzerbeslag
- het nummer van de handleiding
- het op het pakket vermelde referentienummer van het meubel

Wij hebben deze 3 gegevens nodig om u een accurate en snelle service te kunnen garanderen.



ENTRETIEN

Avant de nettoyer, dépoussiérer soigneusement avec un chiffon doux et propre
Mettre le produit sur le chiffon plutôt que sur le meuble
Ne jamais mouiller copieusement
Ne jamais utiliser de poudre ou éponges à récureur, de laine d'acier ou de lessive décapante
Dépoussiérer les coulisses de tiroir et lubrifier les axes de charnières.

GB - MAINTENANCE

Before cleaning, carefully dust with a clean, soft cloth.
Put any dusting product on the cloth rather than on the cabinet.
Avoid overly wetting.
Never use scouring powders or sponges, steel wool or abrasive cleaning products.
Dust drawer slides and lubricate hinges.

D - WARTUNG

Vor Reinigung sorgfältig mit einem weichen und sauberen Tuch abstauben.
Das Produkt lieber auf das Tuch als auf das Möbel geben.
Nicht zu stark befeuchten.
Keine Scheuerpulver oder -schwämme, Stahlwolle oder Beizmittel verwenden.
Die Schubladengleitschienen abstauben, und die Scharnierachsen schmieren.

E - LIMPIEZA

Antes de limpiar, retirar el polvo cuidadosamente con un trapo suave y limpio
Colocar el producto de limpieza más bien en el trapo que en el mueble
Jamás mojar abundantemente
Jamás utilizar polvos detergentes, esponjas abrasivas, lana de acero ni detergente decapante
Sacar el polvo de las correderas del cajón y lubricar los ejes de las bisagras.

P - LIMPEZA

Antes de limpar, limpe cuidadosamente o pó com um pano macio e limpo
Pôr o produto no pano e não sobre o móvel
Nunca molhe muito o pano
Nunca utilize pó ou esponjas de arear, lâ de aço ou sabão em pó decapante
Limpe o pó das corredeiras das gavetas e lubrifique os eixos de dobradiças.

I - MANUTENZIONE

Prima di pulire, spolverare con cura con un panno morbido e pulito
Mettere di preferenza il prodotto sul panno e non sul mobile
Non bagnare mai copiosamente
Non usare mai detersivi o spugne abrasive, lana d'acciaio, prodotti per decappaggio
Spolverare le guide dei cassetti e lubrificare gli assi delle cerniere.

NL - ONDERHOUD

Voor het reinigen zorgvuldig afstoffen met een schone, zachte doek
Brenghet product liever aan op de doek dan rechtstreeks op het meubel
Nimmer teveel water gebruiken
Nimmer schuurpoeder, schuurponsjes, staalwol of afbijtmiddelen gebruiken.
Maak de ladelopers stofvrij en smeer de scharnierpenen.