

0321BAHU

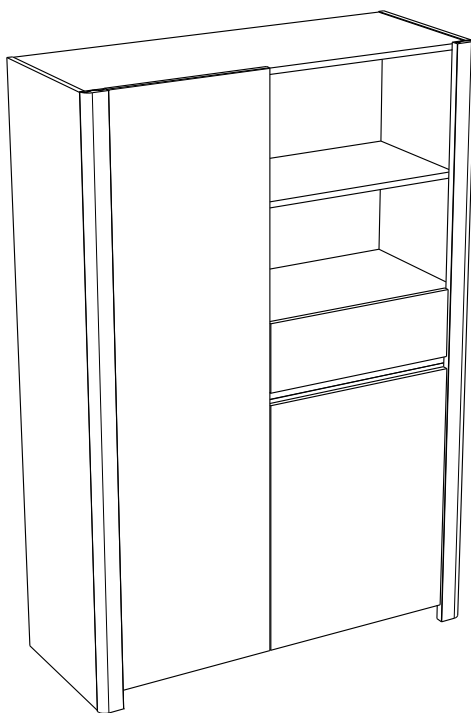

FR Remerciements :

Nous vous remercions d'avoir choisi un meuble créé et fabriqué par le Groupe Parisot et espérons qu'il vous donnera entière satisfaction.

EN Thanks:

Thank you for choosing furniture designed and manufactured by the Parisot Group. We hope you are totally satisfied with your purchase.

DE Danksagung:

Wir danken Ihnen für den Kauf eines Frankreich von der Parisot-Gruppe entworfenen und hergestellten Möbelstücks und hoffen, dass Sie es zu Ihrer vollkommenen Zufriedenheit finden werden.

ES Agradecimientos:

Les damos las gracias por haber elegido un mueble diseñado y fabricado por el Groupe Parisot y esperamos que sea de su total agrado.

PT Agradecimentos:

Obrigado por ter escolhido um móvel concebido e fabricado pelo Grupo Parisot, esperando que seja do seu inteiro agrado.

IT Ringraziamenti:

Grazie per avere scelto un mobile progettato e fabbricato dal Gruppo Parisot. Speriamo soddisfisi appieno le vostre esigenze.

NL Bedankje:

Wij bedanken u voor de aankoop van een door de Groep Parisot ontworpen en vervaardigd meubel en hopen dat u er veel plezier aan zult beleven.

CZ Poděkování:

Děkujeme, že jste si vybrali nábytek navržený a vyrobený společností Parisot Group. Doufáme, že budete svým nákupem naprosto spokojeni.

HU Köszönet:

Köszönjük, hogy a Parisot Groupe által létrehozott és gyártott bútort választott, reméljük, hogy elégedett lesz a termékkel.

PL Podziękowania:

Dziękujemy za wybór mebli stworzonych i wyprodukowanych przez Grupę Parisot. Mamy nadzieję, że będziecie Państwo w pełni zadowoleni z zakupu.

RO Mulțumiri:

Vă mulțumim că ați ales un articol de mobilier conceput și fabricat de Grupul Parisot și sperăm că veți fi pe deplin satisfăcuți de acesta.

RU Благодарность:

Мы благодарим вас за то, что вы выбрали мебель, созданную и произведенную Групп Паризо, и надеемся, что вы будете полностью удовлетворены нашей продукцией.

SK Poďakovanie:

Ďakujeme, že ste si vybrali nábytok navrhnutý a vyrobený spoločnosťou Parisot Group. Dúfame, že budete svojim nákupom absolútne spokojní.

TR Teşekkür ederiz:

Parisot Group tarafından tasarlanan ve üretilen bu mobilyayı seçtiğiniz için teşekkür ederiz. Ürünümüzden memnun kalmanızı ümit ederiz.

AR : شكر

نشكركم لاختياركم هذه القطعة من الأثاث من تصميم وتصنيع مجموعة باريزو Parisot ونتمنى أن تتال رضاءكم.

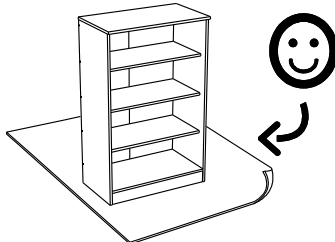
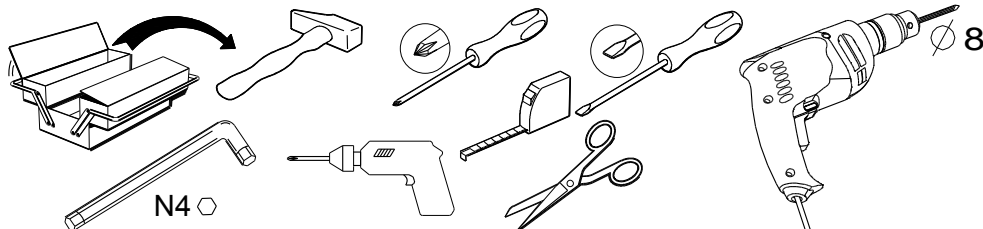

contact@parisot.com

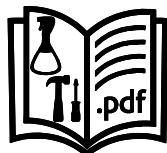

www.parisot.com

152cm
59 3/4"
104cm
41"
41.5cm
16 1/4"

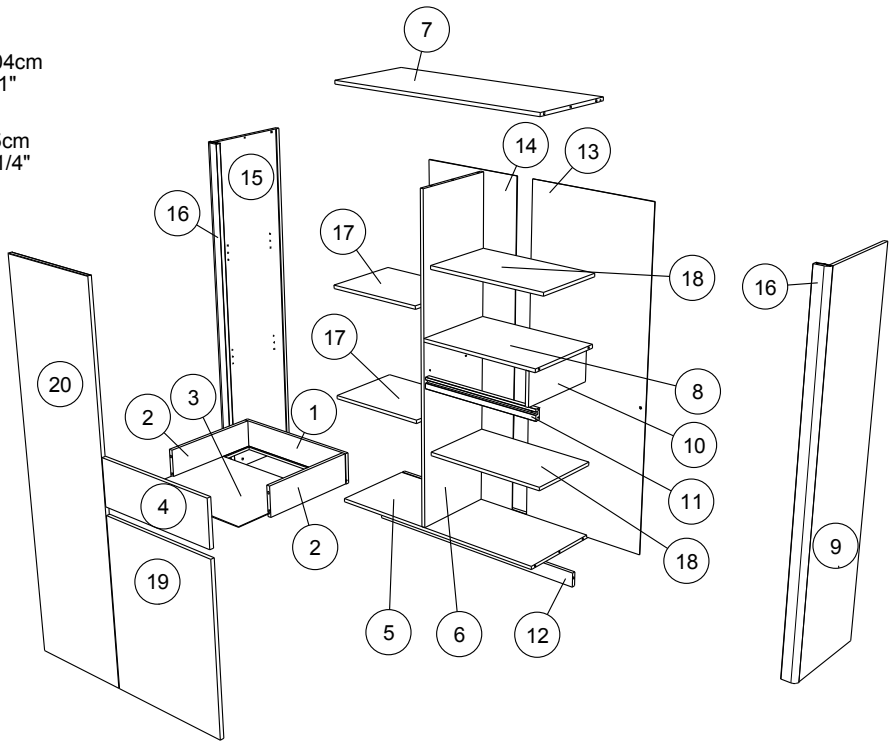

		mm			inch		
⑩	x 1	370	147	15	14 9/16	5 13/16	9/16
⑪	x 2	437	328	15	17 3/16	12 15/16	9/16
④	x 1	502	175	15	19 3/4	6 7/8	9/16
⑪	x 1	550	50	22	21 5/8	1 15/16	7/8
⑱	x 2	550	328	15	21 5/8	12 15/16	9/16
⑧	x 1	550	369	15	21 5/8	14 1/2	9/16
⑲	x 1	650	504	15	25 9/16	19 13/16	9/16
⑫	x 1	1002	61	15	39 7/16	2 3/8	9/16
⑦	x 1	1002	390	15	39 7/16	15 3/8	9/16
⑤	x 1	1002	390	15	39 7/16	15 3/8	9/16
⑥	x 1	1423	369	15	56	14 1/2	9/16
⑳	x 1	1471	408	15	57 15/16	16 1/16	9/16
⑨	x 1	1515	390	15	59 5/8	15 3/8	9/16
⑮	x 1	1515	390	15	59 5/8	15 3/8	9/16
⑯	x 2	1516	60	22	59 11/16	2 3/8	7/8
②	x 2	352	110	13	13 7/8	4 5/16	1/2
①	x 1	485	110	13	19 1/8	4 5/16	1/2
③	x 1	467	364	3	18 3/8	14 5/16	1/8
⑭	x 1	1439	453	3	56 5/8	17 13/16	1/8
⑬	x 1	1439	565	3	56 5/8	22 1/4	1/8

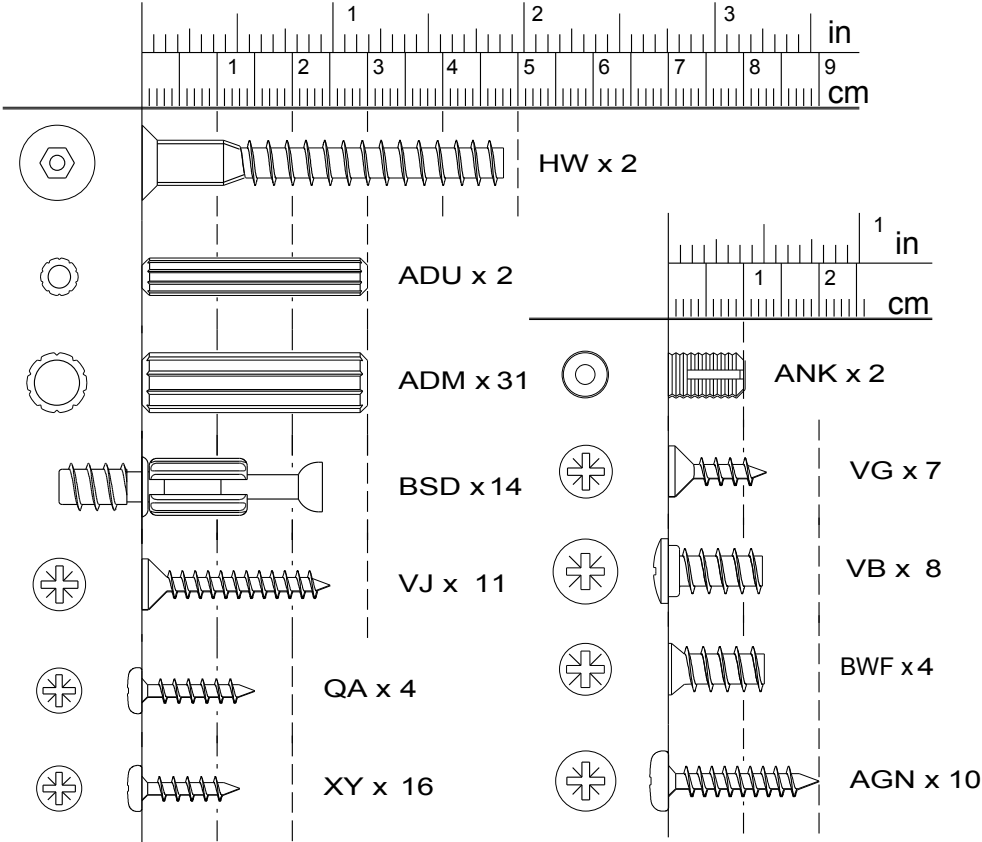
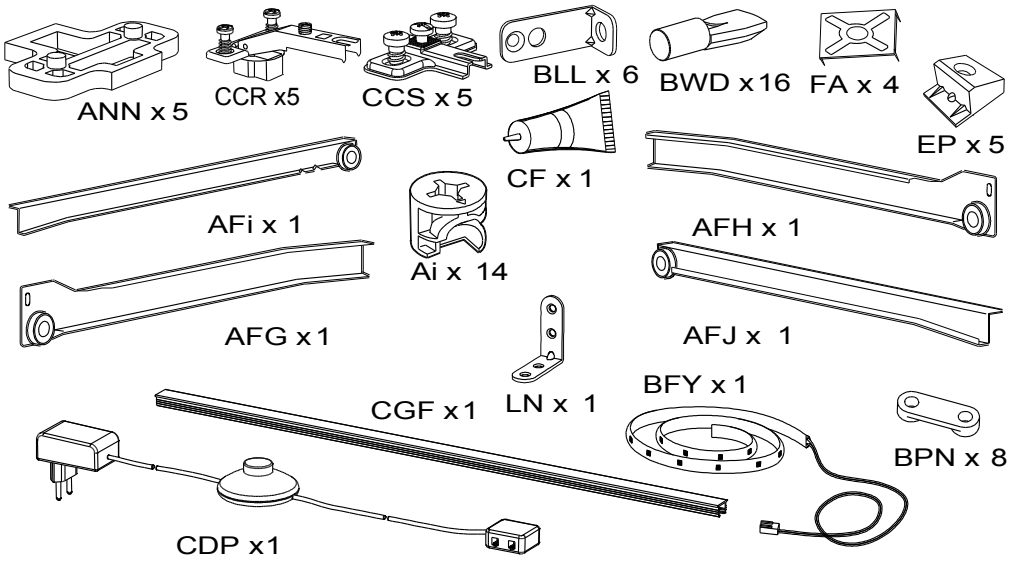

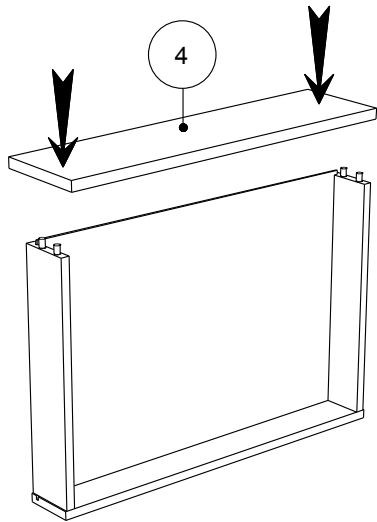
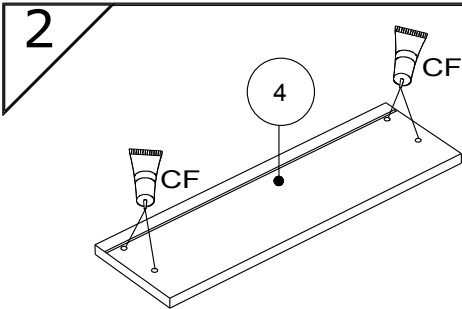
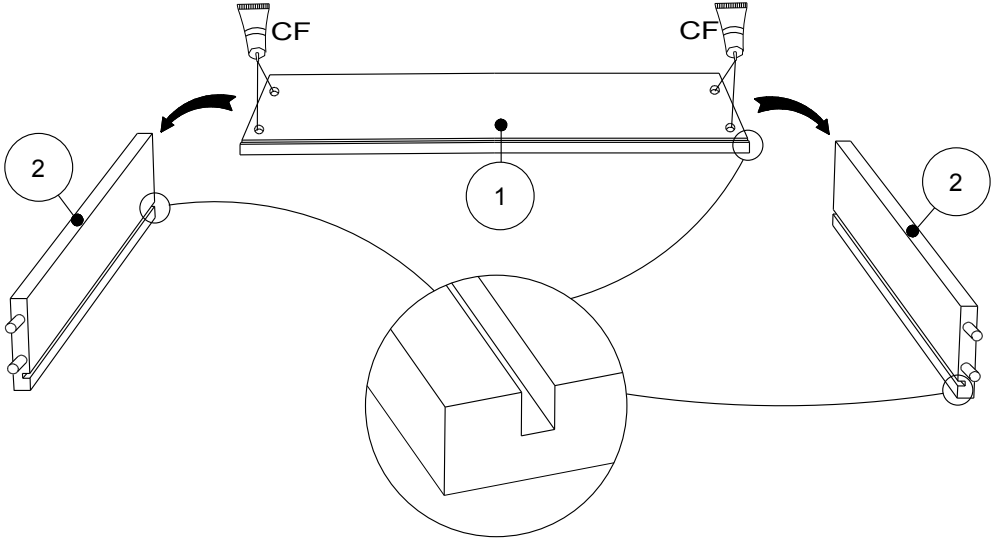
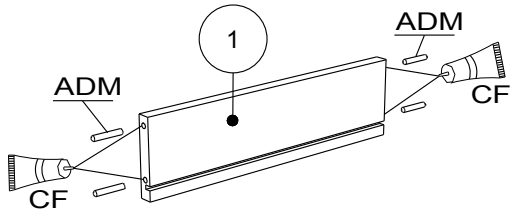
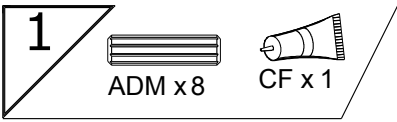

3

BWF x 2

AFG x1

ADM x8

BSD x 1

ANK x 1

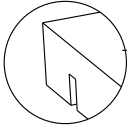
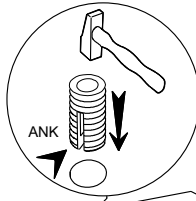
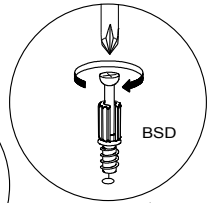

ADM

5

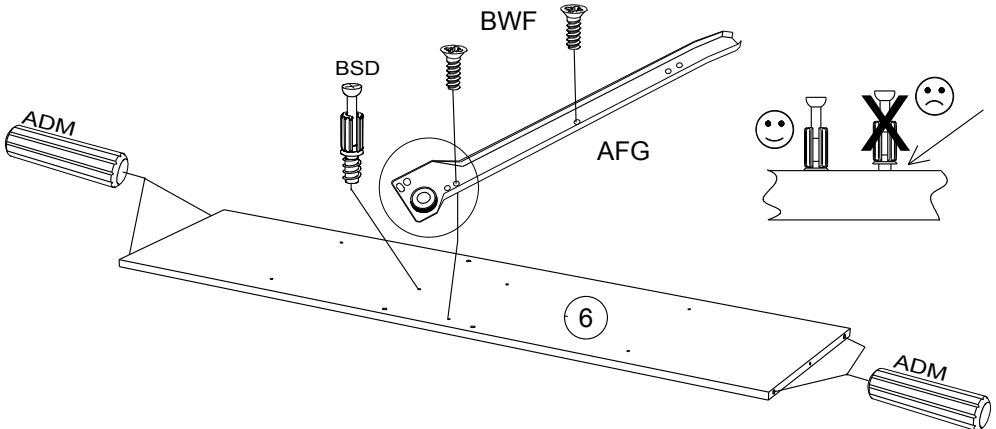

BWF

BSD

AFG

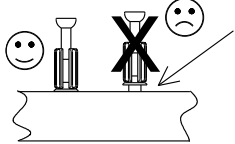

6

ADM

4

HW x 1

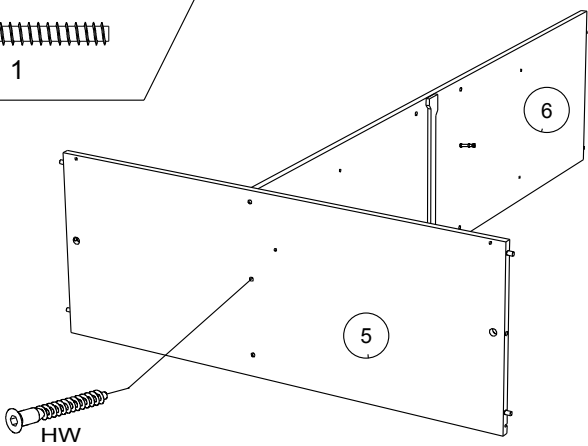

6

5

HW

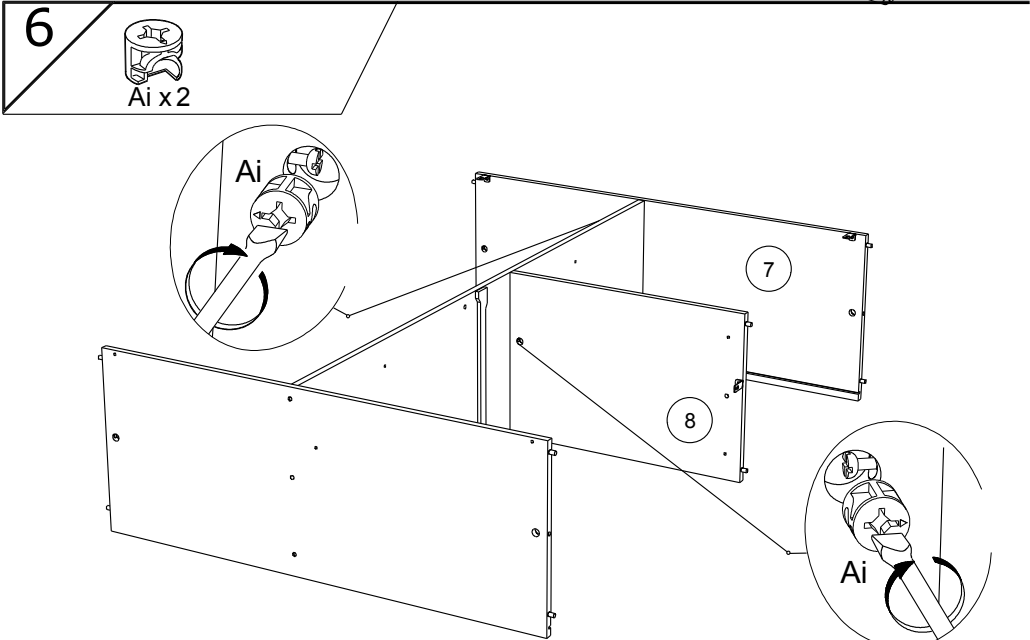
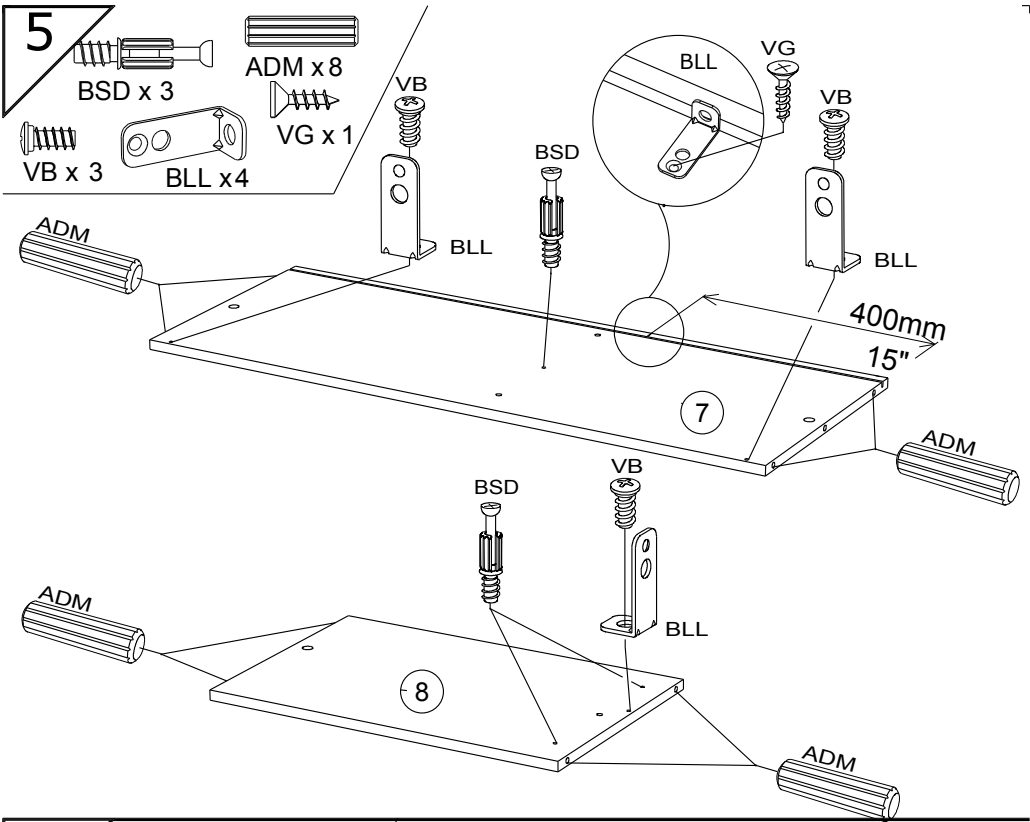

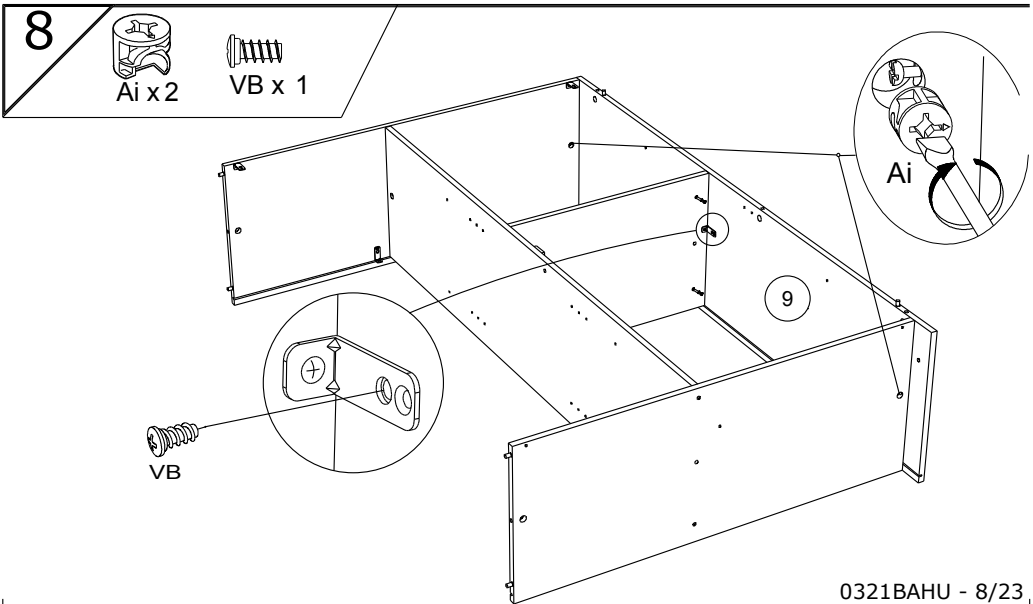
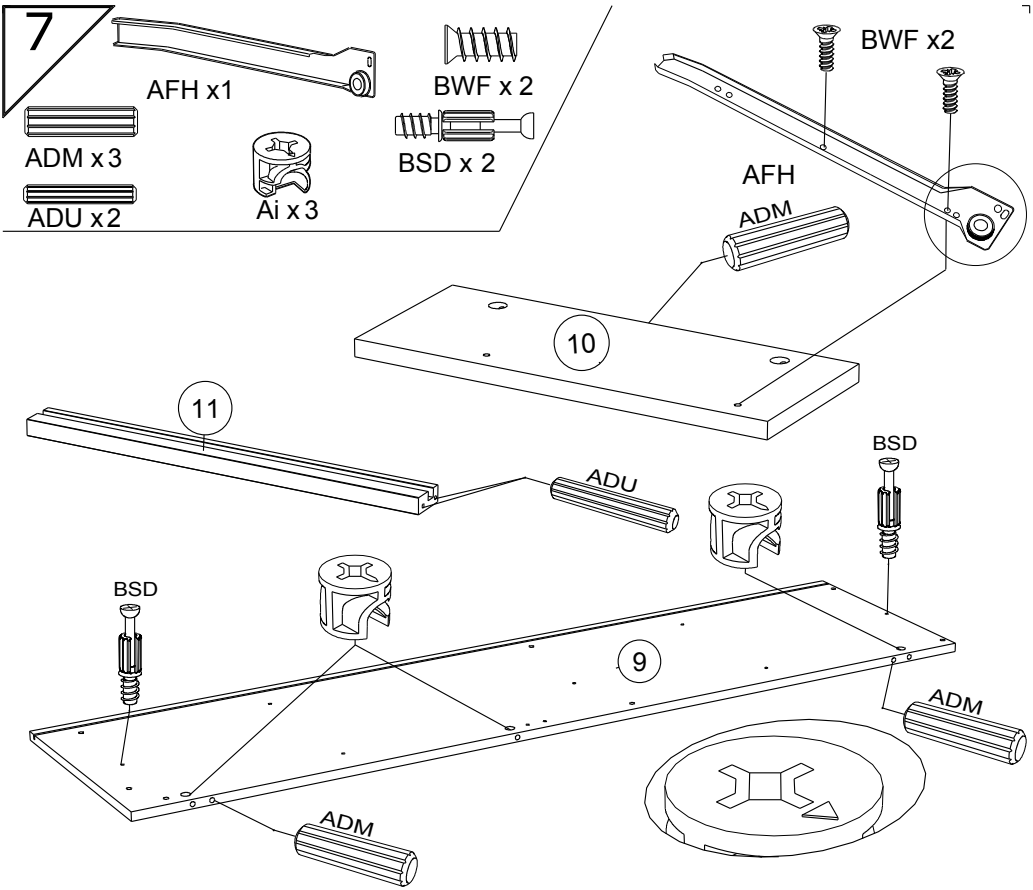

9
Ai x 2

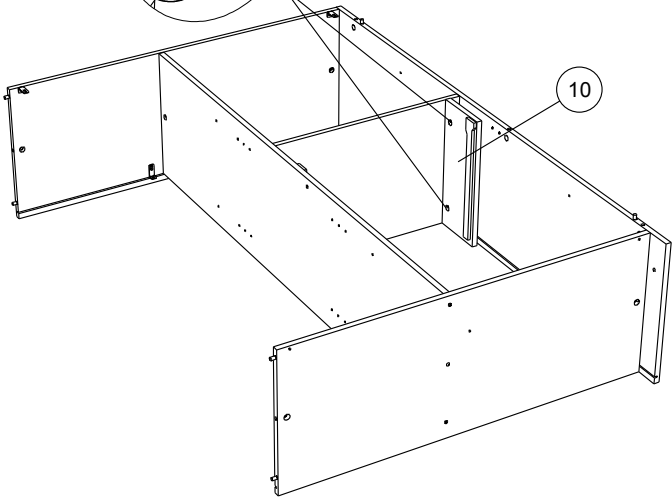
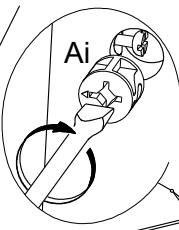

10
HW x 1

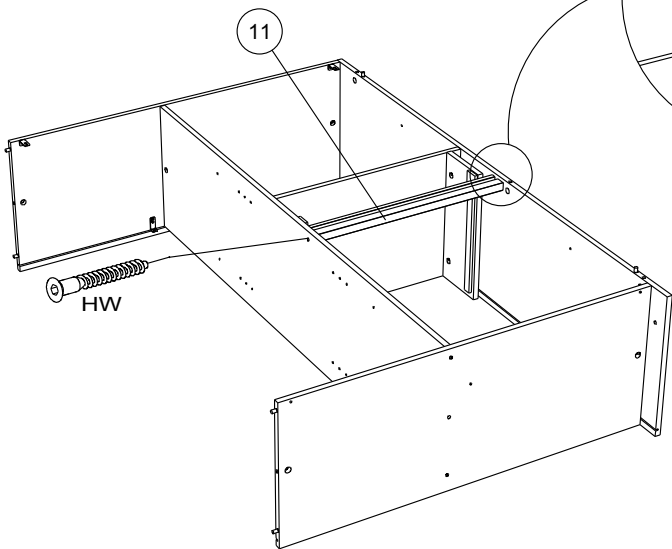
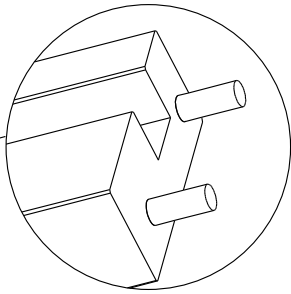
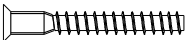

11

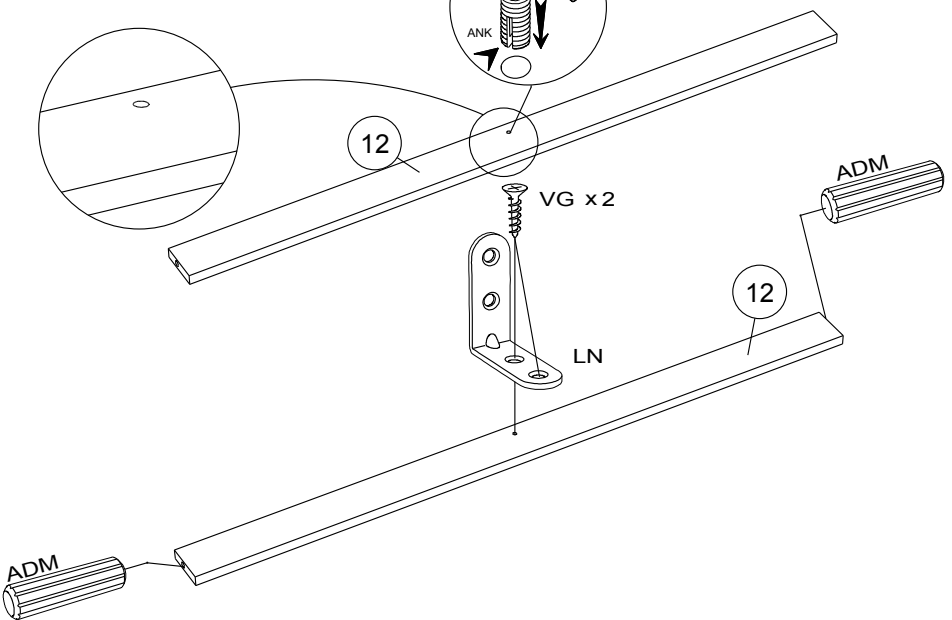
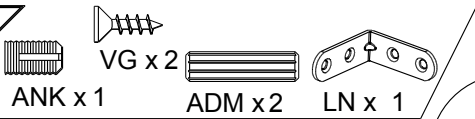

12

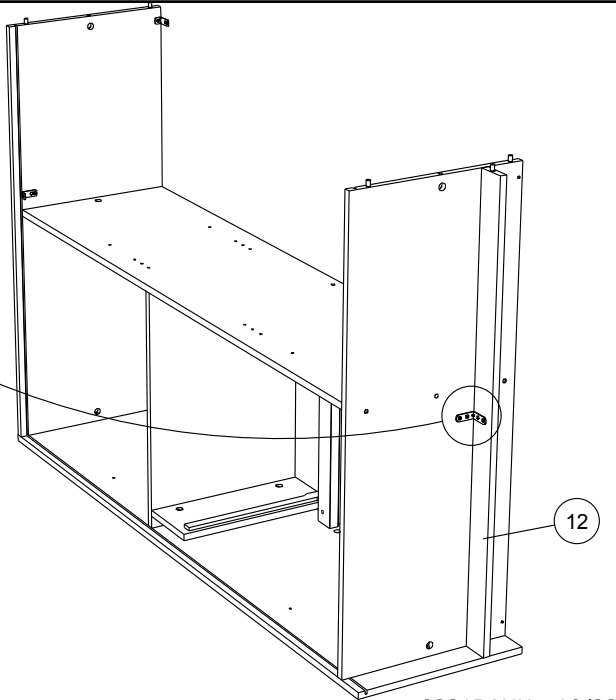
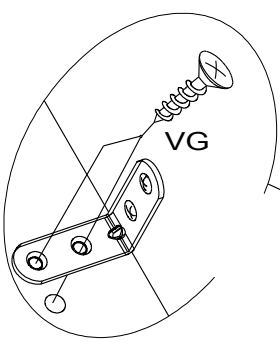



13

BSD x 2 ADM x 2

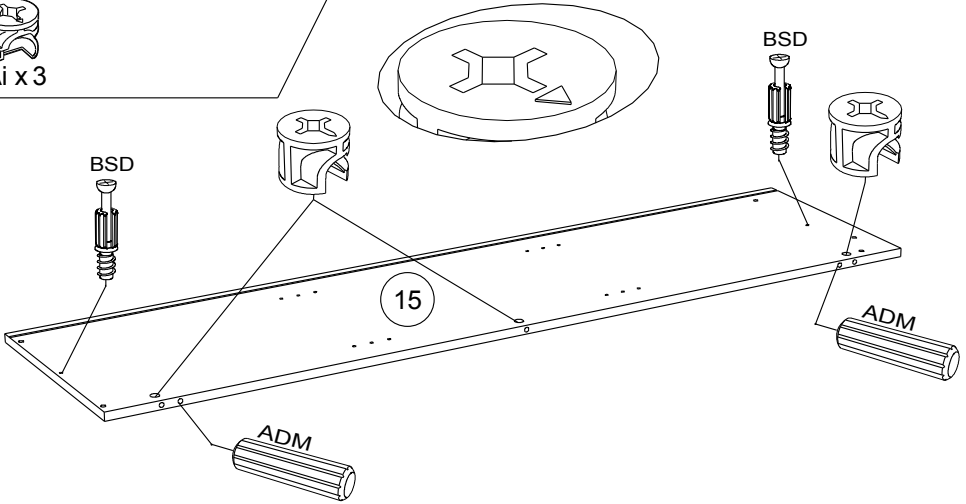
Ai x 3



14

 13	1439 x 565 x 3
 14	1439 x 453 x 3

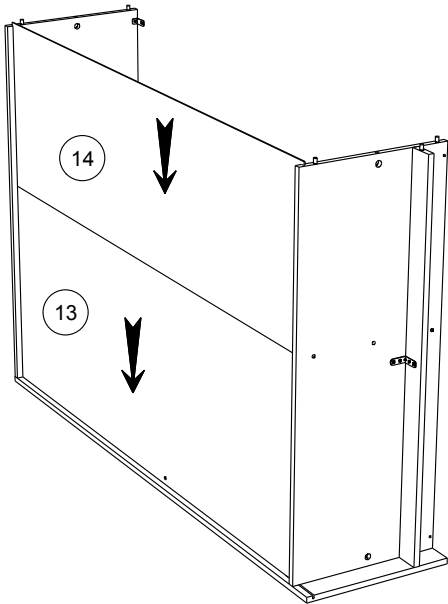

15



Ai x2



EP x4

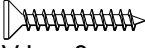

VJ x 8



FA x4

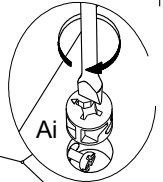

Ai

14mm
1/2"

15

620mm
24"

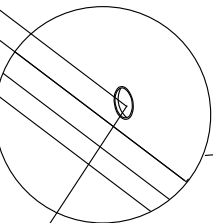

8

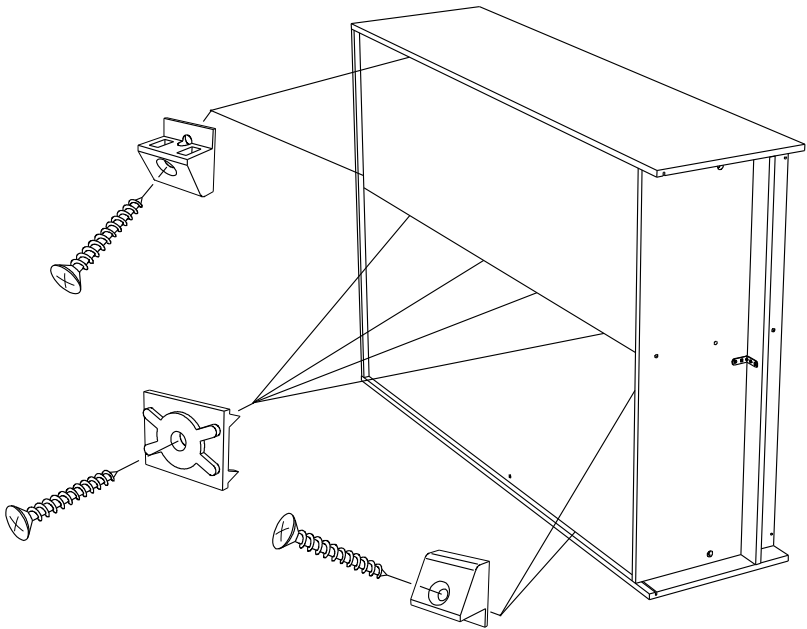
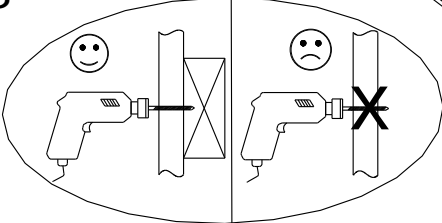
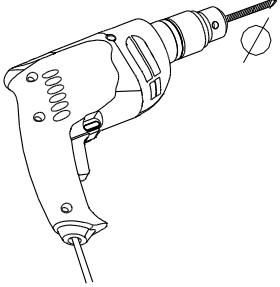

16

CCF x 1

BYF x 1

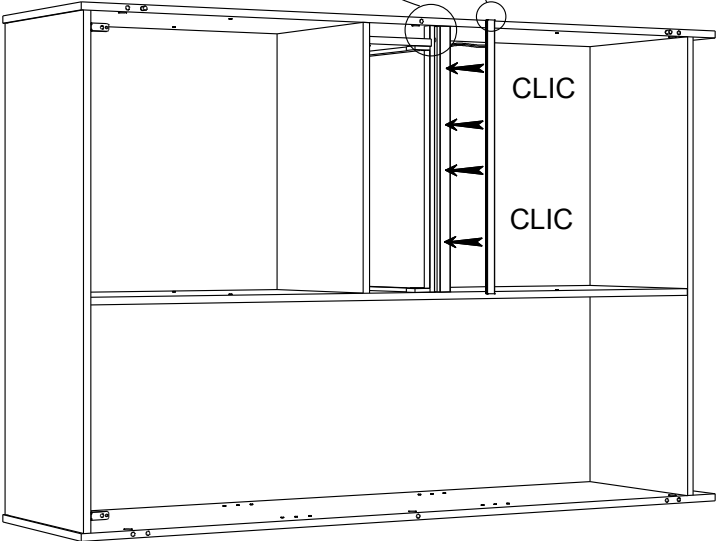
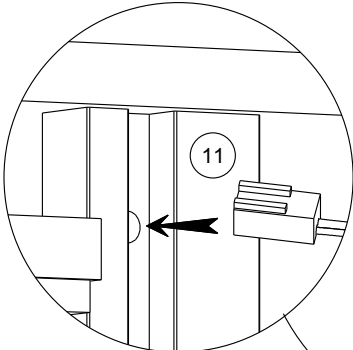
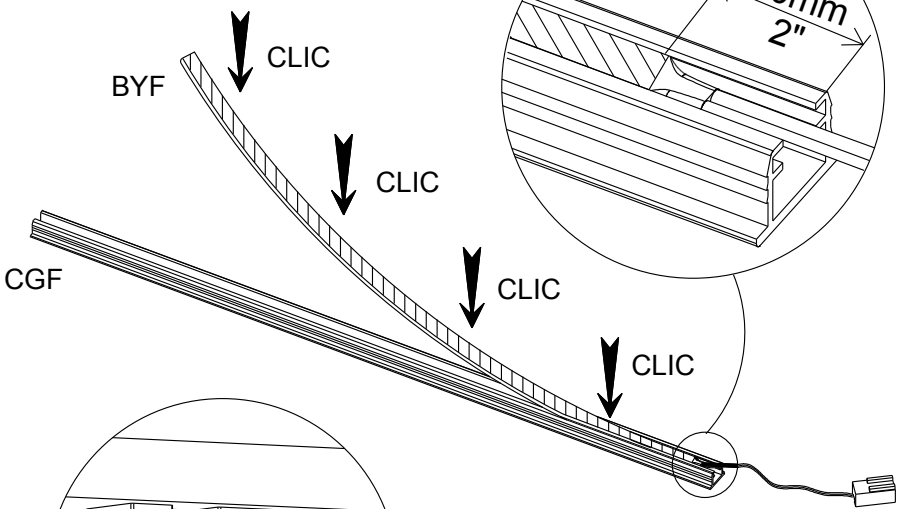
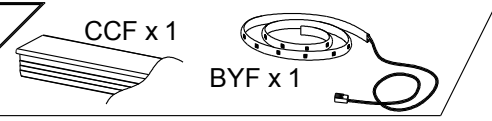

17

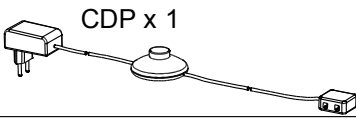

CDP x 1

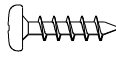

XY x 4



BPN x 2

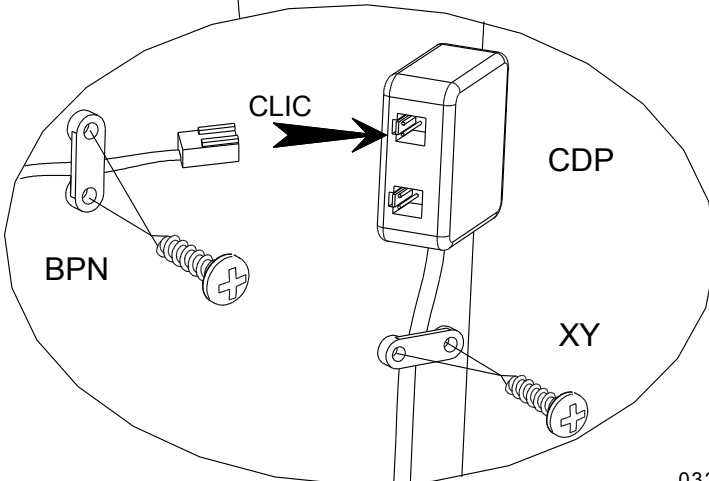
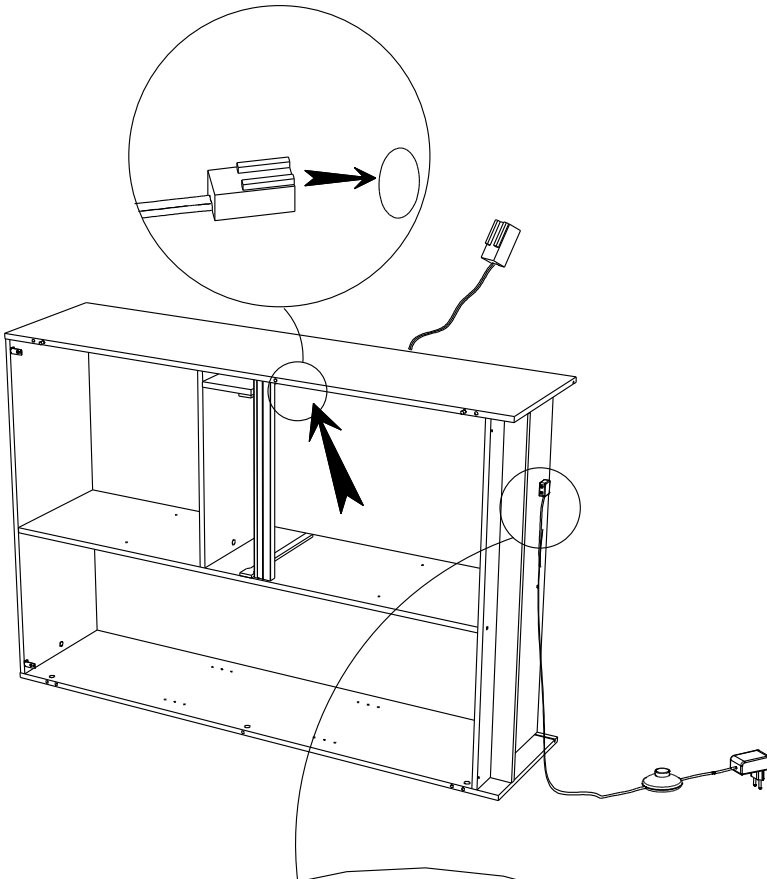

CLIC

CDP

BPN

XY

18

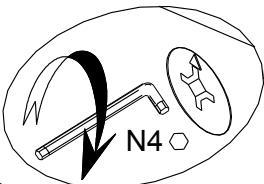
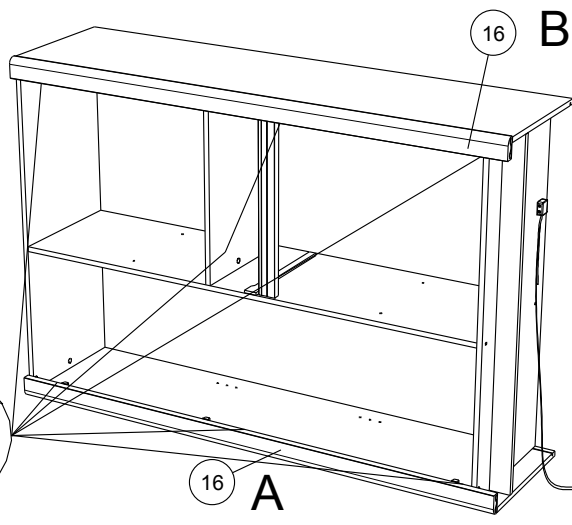
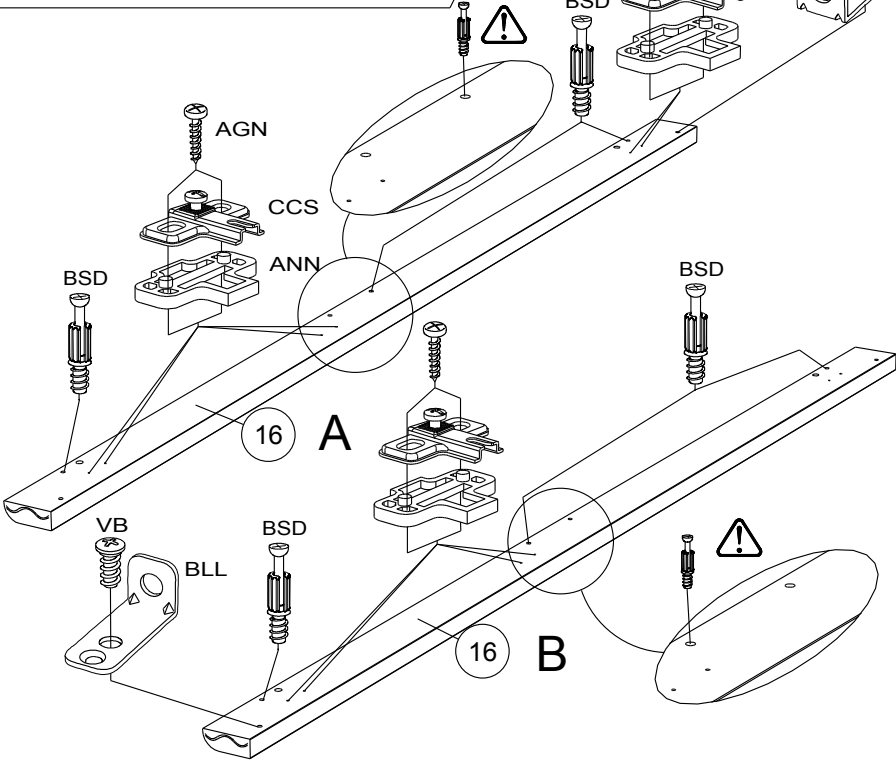
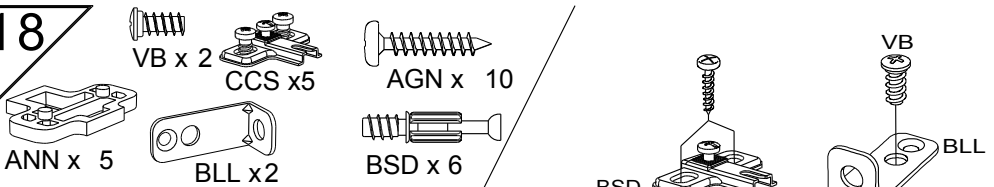

19



VG x 2



VB x 2



VG

VB

20



BPN x 2

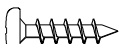

XY x 4

BPN x 2

XY x 4

21



VJ x 1



BPN x 1



XY x 2

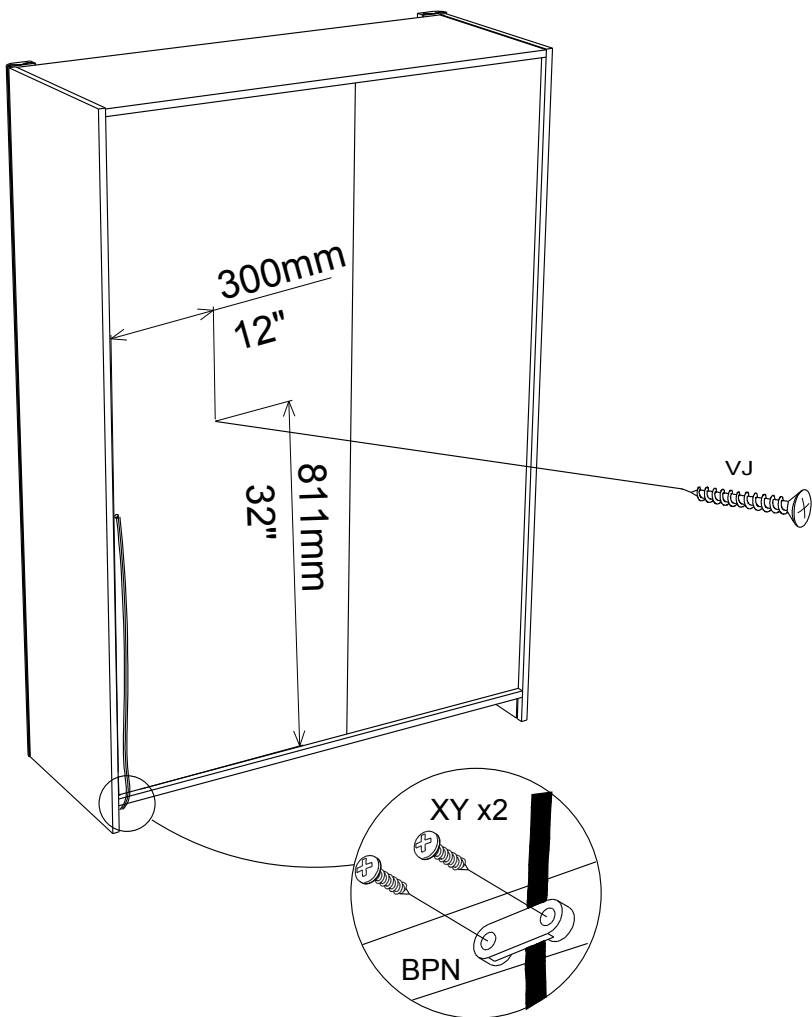

22

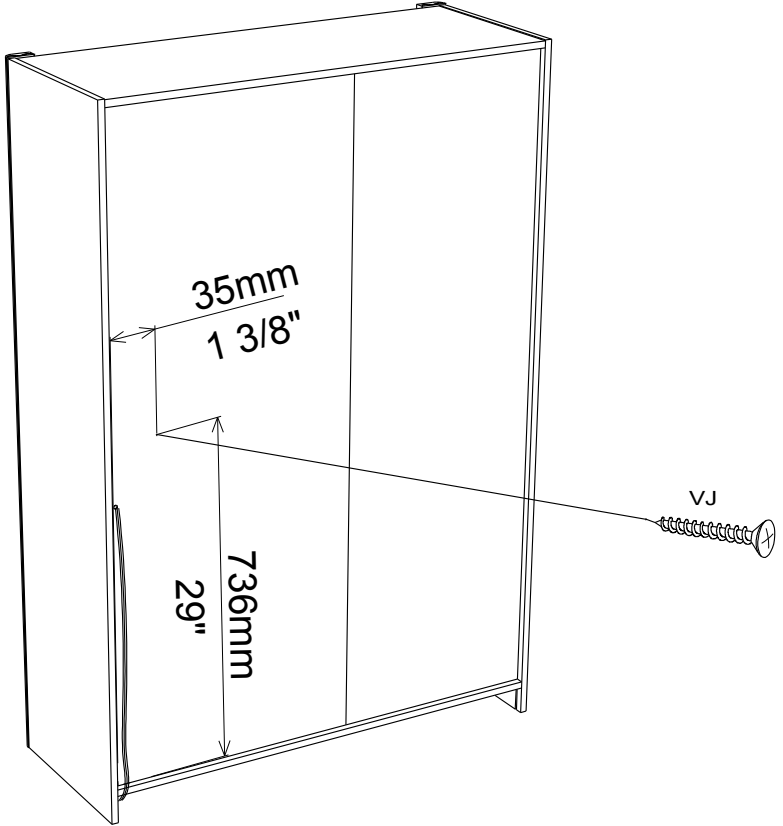
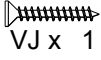

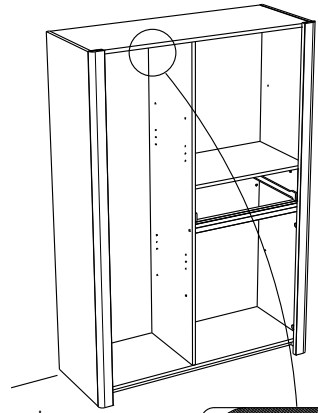

- FR** Pour votre sécurité : Fixation du meuble au mur
Attention, la fixation doit être réalisée par une personne compétente car cela nécessite des chevilles adaptées à la nature de votre mur.
- EN** For your safety: the unit should be secured to the wall.
NB this should be carried out by a competent person as you must use the right rawlplug for your type of wall.
- DE** Zu Ihrer Sicherheit: Befestigen Sie das Hochbett an der Wand.
Achtung: Diese Befestigung ist durch eine fachlich kompetente Person vorzunehmen. Hierfür sind für die Bauweise Ihrer Wand geeignete Dübel einzusetzen.
- ES** Por su seguridad: Fijar el mueble a la pared.
Advertencia: la fijación la ha de llevar a cabo por personal adecuado, ya que requiere el uso de tacos que se adapten al tipo de pared.
- PT** Para sua segurança: fixação do móvel ao muro
Atenção: a fixação deverá ser efetuada por pessoa habilitada, visto que são necessárias cavilhas adaptadas ao tipo de parede.
- IT** Avvertenza di sicurezza: il fissaggio del mobile a parete deve essere realizzato da una persona competente, in quanto l'operazione richiede l'impiego di tasselli adatti alla natura del muro.
- NL** Voor uw veiligheid: bevestiging van het meubel aan de muur.
Opgelet de bevestiging moet worden uitgevoerd door een bekwam persoon daar dit voor uw type muur geschikte pluggen vereist.
- CZ** Z bezpečnostních důvodů: upevněte nábytek do zdi
Pozor, upevnění je třeba svěřit kompetentní osobě, neboť vyžaduje hmoždinky vhodné pro vaši zeď.
- HU** Az Ön biztonsága érdekében : a bútor falra rögzítése
Figyelmeztetés : a rögzítés csak megfelelő szakképesítéssel rendelkező személy által végezhető el, mert a rögzítéshez a falnak megfelelő csavarokra van szükség.
- PL** Dla bezpieczeństwa: mocowanie mebla do ściany
Uwaga, mocowanie musi zostać wykonane przez osobę kompetentną, ponieważ wymaga to zastosowania kółków dostosowanych do rodzaju ściany.
- RO** Pentru securitatea dumneavoastră: fixarea mobilierului de perete
Atenție, fixarea trebuie să fie realizată de o persoană calificată, deoarece sunt necesare dispozitive de fixare adaptate caracteristicilor peretelui dumneavoastră
- RU** Для вашей безопасности: Крепление мебели к стене
Внимание! Крепление должно производиться опытным специалистом, т.к. для такой установки потребуются штифты, соответствующие типу вашей стены.
- SK** Z bezpečnostných dôvodov: nábytok upevnite k stene.
Dbajte na to, aby upevnenie vykonala kompetentná osoba, pretože pri upevňovaní sa vyžadujú kolíky vhodné do materiálu, z ktorého je stena vyrobená.
- TR** Güvenliğiniz için: Mobilyanın duvara sabitlenmesi
Dikkat, sabitleme işlemini uzman biri tarafından yapılmalıdır çünkü bu işlem için duvarınızın malzemesine uygun dübellerin kullanılması gerekmektedir
- GR** Για την ασφάλειά σας : στερέωση των επίπλων στον τοίχο.
Προσοχή, η στερέωση πρέπει να γίνεται από ικανό άτομο, καθώς απαιτούνται σφηνές προσαρμοσμένες στη φύση του τοίχου σας.

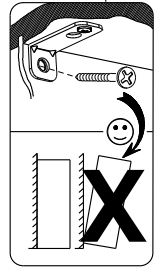

اللغة العربية

لسلامتك الشخصية: تثبيت قطعة الأثاث على الحائط
تحذير، يجب أن يقوم شخص متخصص بعملية التثبيت على الحائط إذ أنها تتطلب اسفينا
معينا يتوافق مع طبيعة الحائط نفسه.

24

BWD x 16

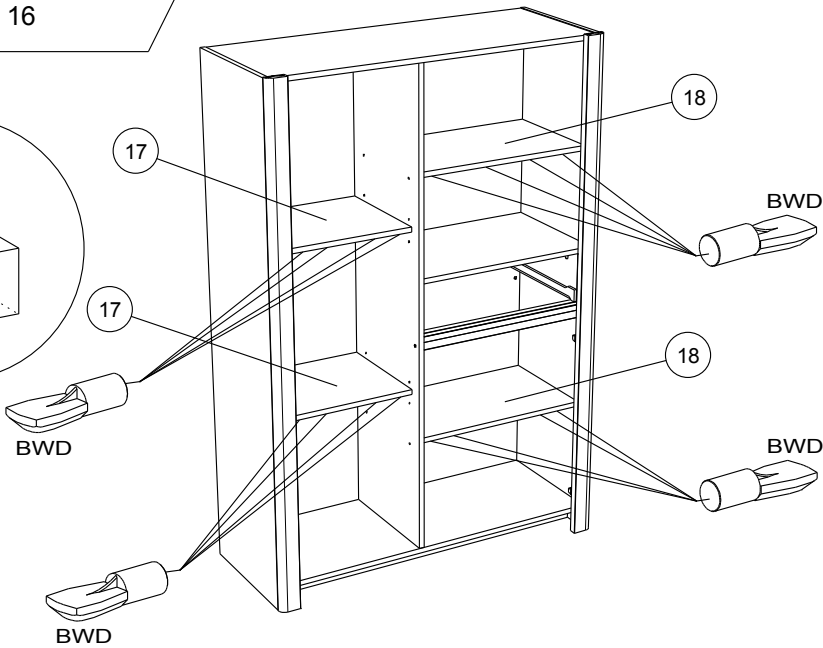
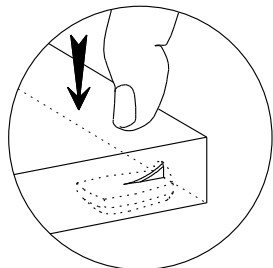

25

AFJ x 1

EP x 1

QA x 4

AFix 1

VJ x 1

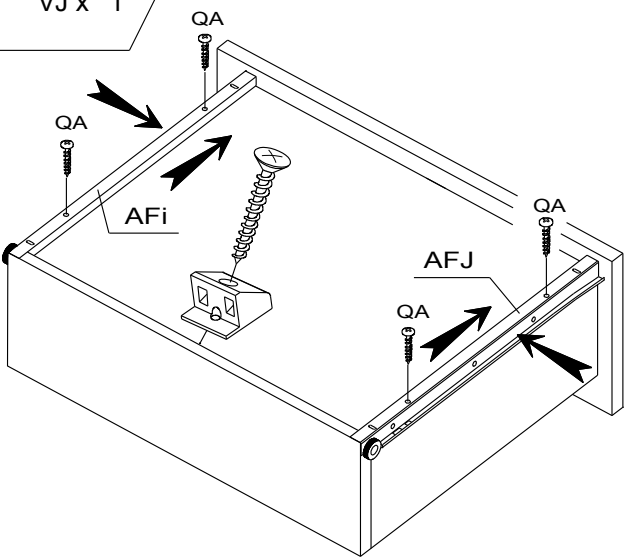

26

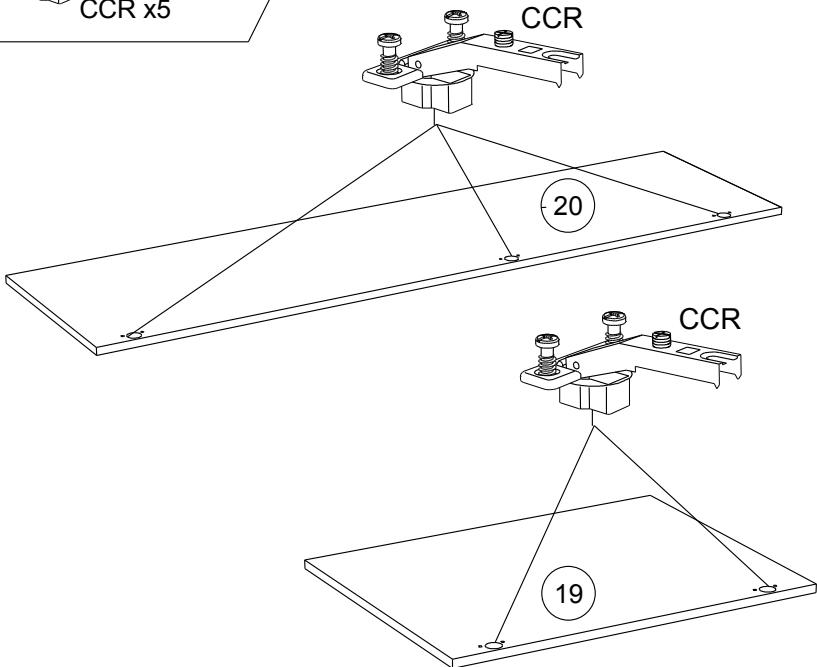
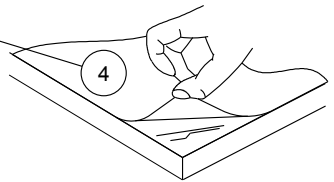
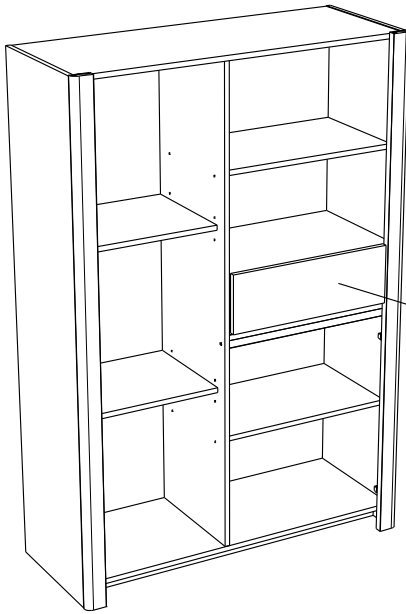

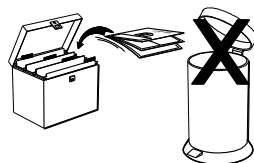
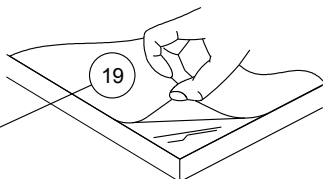

RCH-C-N

MONTAGE

- (GB) LEAFLET
- (D) AUFBAUANLEITUNG
- (E) MONTAJE
- (P) MONTAGEM
- (I) MONTAGGIO
- (NL) MONTAGE

REGLAGE (GB) ADJUSTING (E) AJUSTER (I) AGGIUSTAMENTO (D) ANPASSUNG (P) REGULACAO (NL) AFSTELLING

Faites un geste pour l'environnement en triant vos déchets d'emballage
Make a gesture for the environment by sorting out your waste of packaging
Machen Sie eine Bewegung für die Umwelt, ihre Verpackungsabfälle sortierend
Haga un gesto para el medio ambiente escogiendo sus residuos de embalaje