

9450PATV

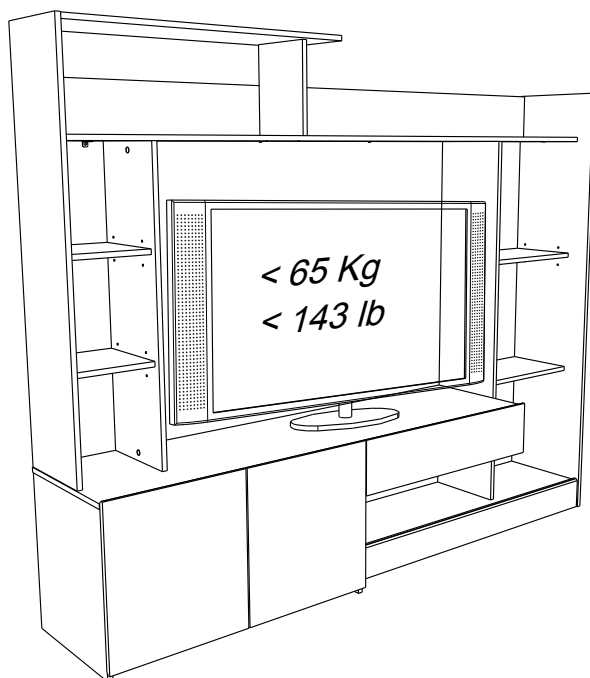

FR Remerciements :

Nous vous remercions d'avoir choisi un meuble créé et fabriqué par le Groupe Pariset et espérons qu'il vous donnera entière satisfaction.

EN Thanks:

Thank you for choosing furniture designed and manufactured by the Pariset Group. We hope you are totally satisfied with your purchase.

DE Danksagung:

Wir danken Ihnen für den Kauf eines Frankreich von der Pariset-Gruppe entworfenen und hergestellten Möbelstücks und hoffen, dass Sie es zu Ihrer vollkommenen Zufriedenheit finden werden.

ES Agradecimientos:

Les damos las gracias por haber elegido un mueble diseñado y fabricado por el Groupe Pariset y esperamos que sea de su total agrado.

PT Agradecimentos:

Obrigado por ter escolhido um móvel concebido e fabricado pelo Grupo Pariset, esperando que seja do seu inteiro agrado.

IT Ringraziamenti:

Grazie per avere scelto un mobile progettato e fabbricato dal Gruppo Pariset. Speriamo soddisfatti appieno le vostre esigenze.

NL Bedankje:

Wij bedanken u voor de aankoop van een door de Groep Pariset ontworpen en vervaardigd meubel en hopen dat u er veel plezier aan zult beleven.

CZ Poděkování:

Děkujeme, že jste si vybrali nábytek navržený a vyrobený společností Pariset Group. Doufáme, že budete svým nákupem naprosto spokojeni.

HU Köszönet.

Köszönjük, hogy a Pariset Groupe által létrehozott és gyártott bútort választott, reméljük, hogy elégedett lesz a termékkel.

PL Podziękowania:

Dziękujemy za wybór mebli stworzonych i wyprodukowanych przez Grupę Pariset. Mamy nadzieję, że będziecie Państwo w pełni zadowoleni z zakupu.

RO Mulțumiri:

Vă mulțumim că ați ales un articol de mobilier conceput și fabricat de Grupul Pariset și sperăm că veți fi pe deplin satisfăcuți de acesta.

RU Благодарность:

Мы благодарим вас за то, что вы выбрали мебель, созданную и произведенную Группой Паризо, и надеемся, что вы будете полностью удовлетворены нашей продукцией.

SK Pod'akovanie:

Ďakujeme, že ste si vybrali nábytok navrhnutý a vyrobený spoločnosťou Pariset Group. Dúfame, že budete svojím nákupom absolútne spokojní.

TR Teşekkür ederiz:

Pariset Group tarafından tasarlanan ve üretilen bu mobilyayı seçtiğiniz için teşekkür ederiz. Ürünümüzden memnun kalmanızı ümit ederiz.

AR : شكر:

نشكركم لاختياركم هذه القطعة من الأثاث من تصميم وتصنيع مجموعة باريزو Pariset ونتمنى أن تتال رضائكم.

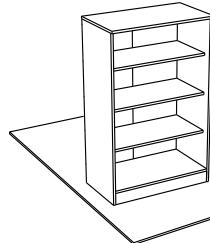
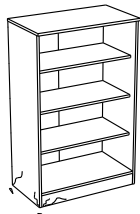
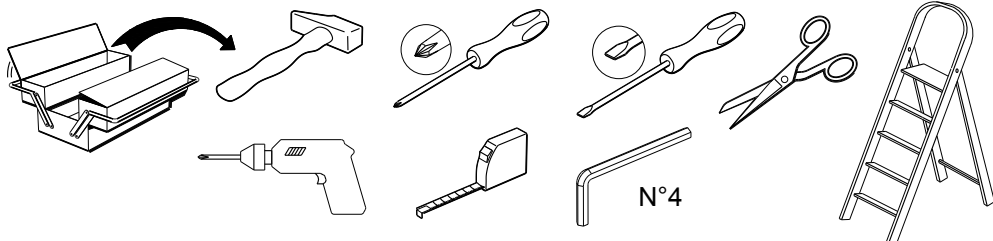

contact@pariset.com

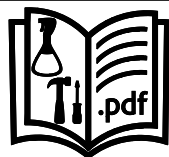

www.pariset.com

165.5cm
65 1/4"
199.5cm
78 1/2"
41cm
16 1/4"

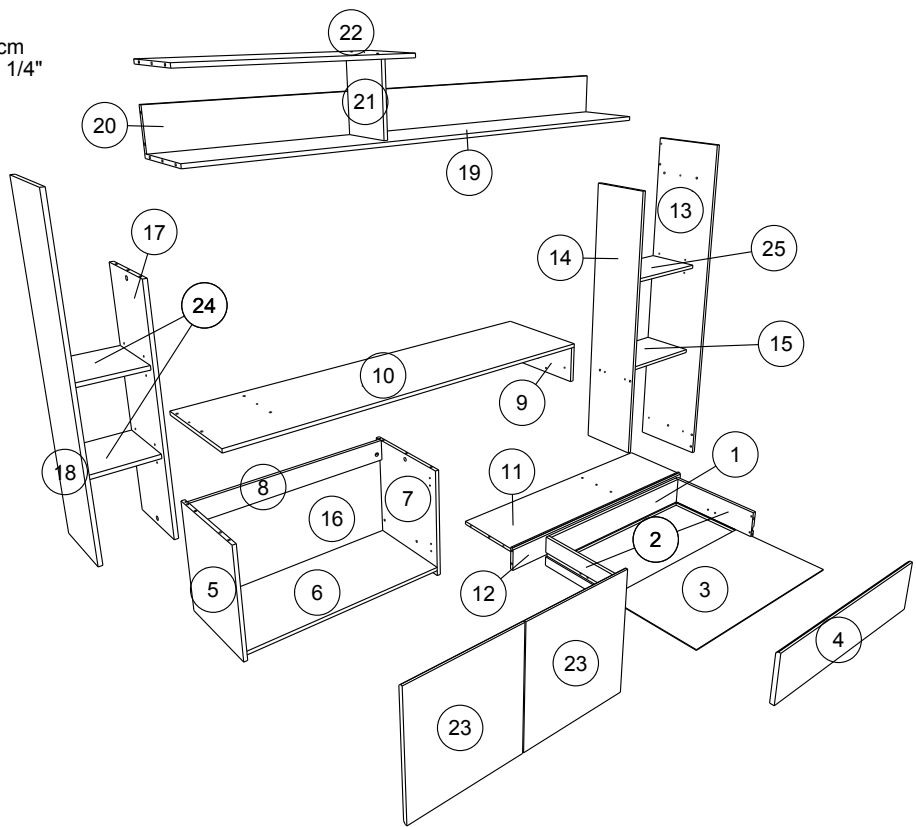

		mm		inch	
24	x	245	15	9 5/8	9 1/4
21	x	270	15	10 5/8	8 1/2
9	x	394	15	15 1/2	5 13/16
25	x	398	15	15 11/16	9 5/8
15	x	398	15	15 11/16	9 5/8
5	x	458	15	18 1/16	15 9/16
7	x	458	15	18 1/16	15 9/16
23	x	461	15	18 1/8	16 3/4
4	x	708	15	27 7/8	6 3/4
8	x	822	15	32 3/8	3 3/8
6	x	822	15	32 3/8	15 9/16
22	x	865	15	34 1/16	10 9/16
17	x	881	15	34 11/16	10 1/2
12	x	1124	15	44 1/4	4 1/4
11	x	1124	15	44 1/4	12 3/16
18	x	1182	15	46 9/16	10 5/8
14	x	1253	15	49 5/16	10 1/2
13	x	1522	15	59 7/8	13
10	x	1565	15	61 5/8	15 9/16
20	x	1961	15	77 3/16	5 15/16
19	x	1961	15	77 3/16	10 9/16
2	x	350	110	13 3/4	4 5/16
1	x	663	110	26 1/8	4 5/16
3	x	674	349	26 9/16	13 3/4
16	x	838	356	33	14

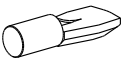

BWD x12

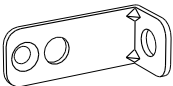

BLL x 2



EP x4



Ai x26

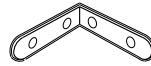

LN x 1

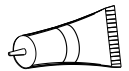

CF x 1

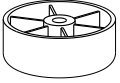

BXC x 1



Ci x2

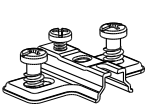

BWU x4

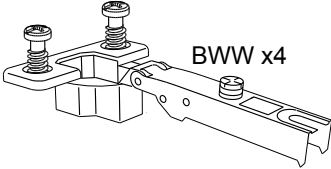

BWW x4

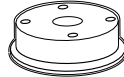

Aii x 1

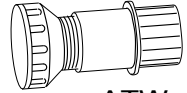

ATW x1

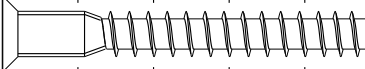
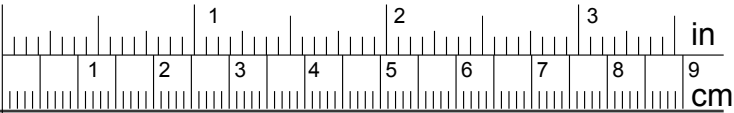

HW x7

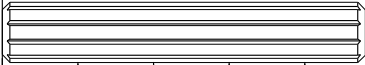

AB x 1

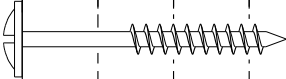

WE x 9

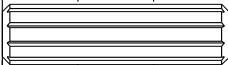

ADM x42



ADU x4

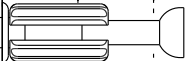

BSD x26

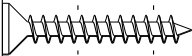

VJ x4

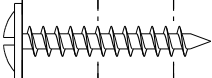

XN x 3

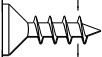

VG x10



ANK x6



VR x2

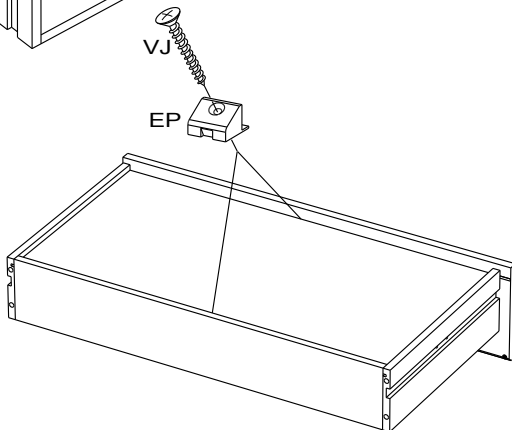
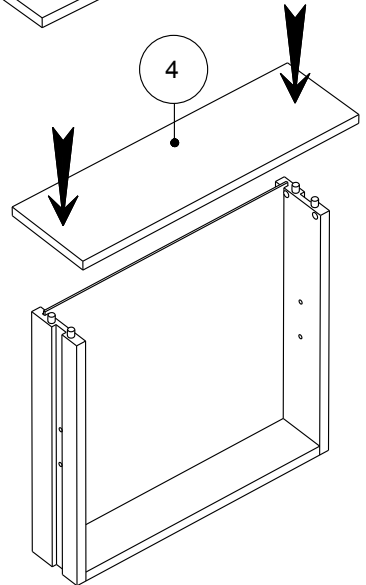
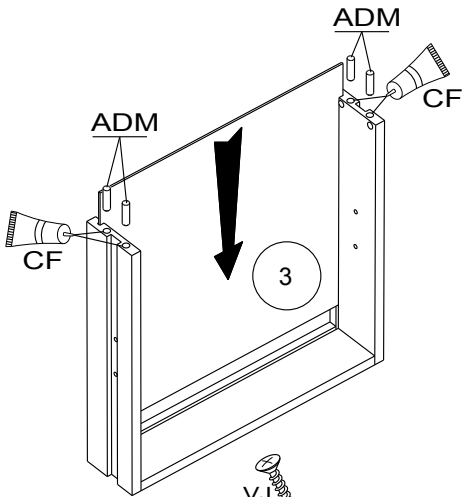
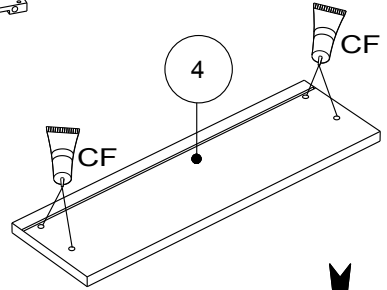
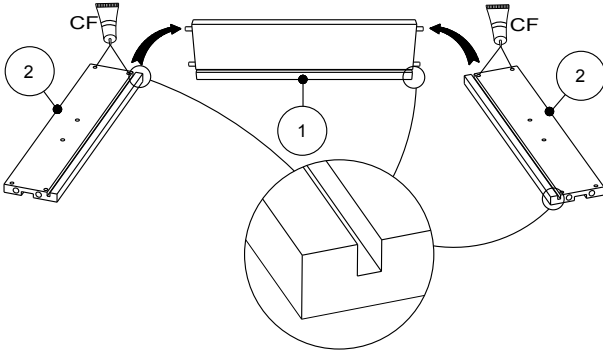
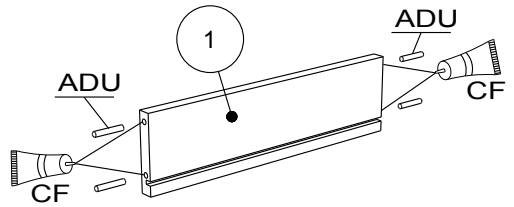
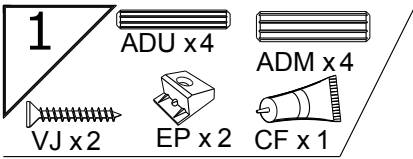

2



AB x 1



ADM x 1



BSD x 3



BWU x 2

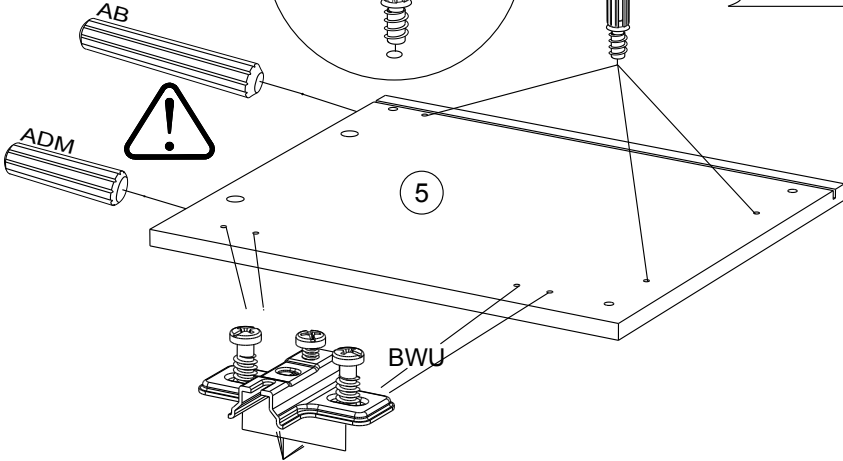
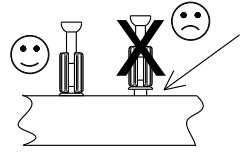
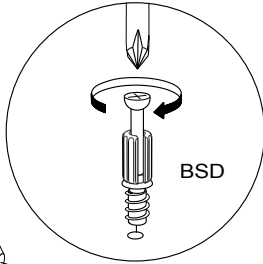

3



BXC x 1



XN x 1



ADM x 4

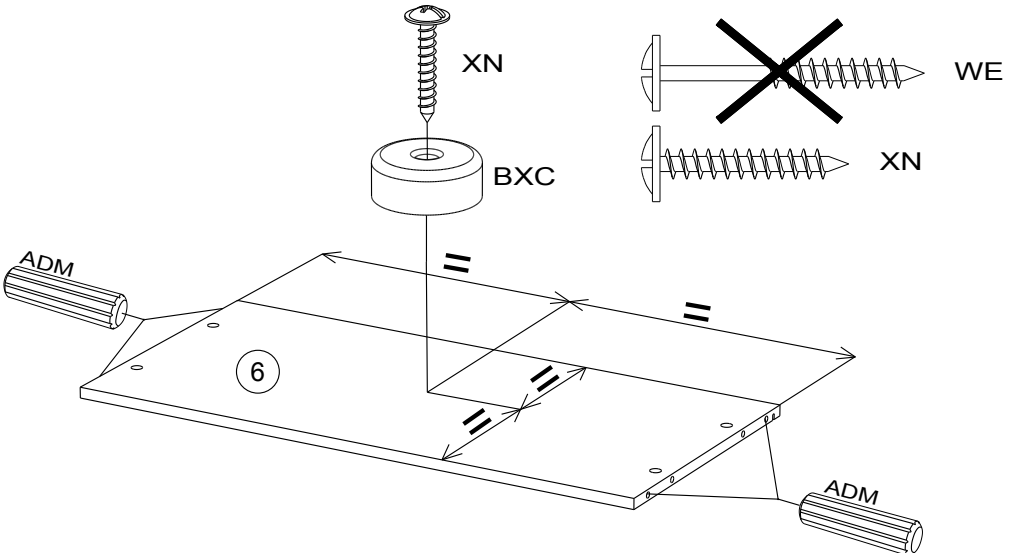

4



VG x 2

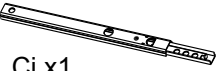

Ci x 1



ANK x 2

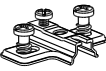

BWU x 2



ADM x 2



BSD x 3

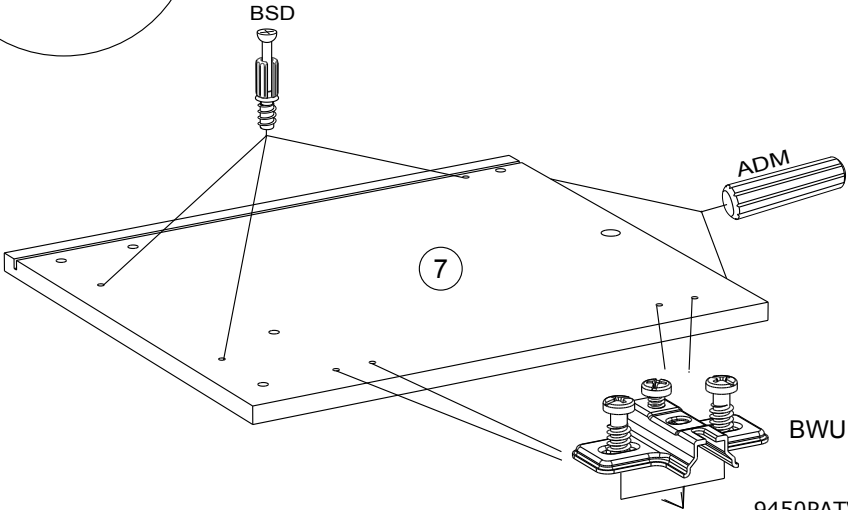
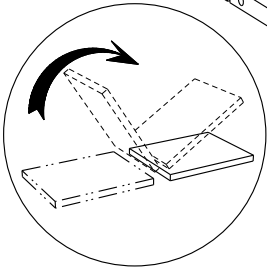
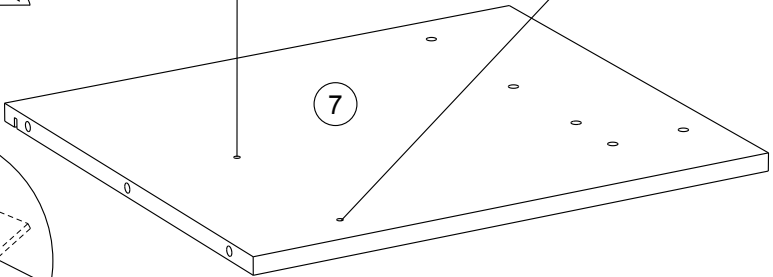
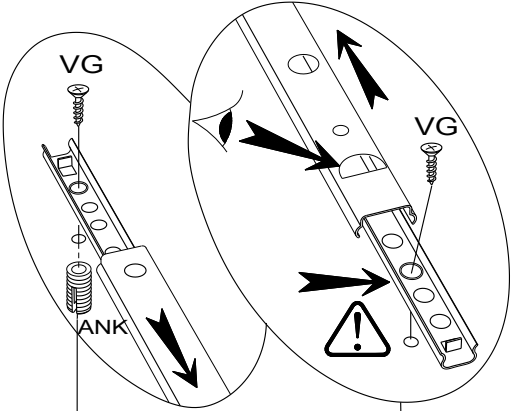
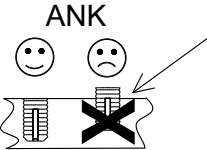
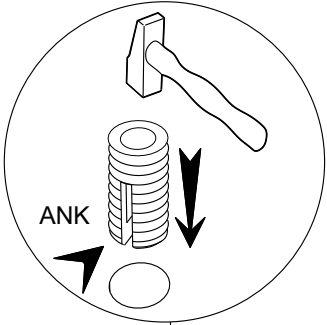

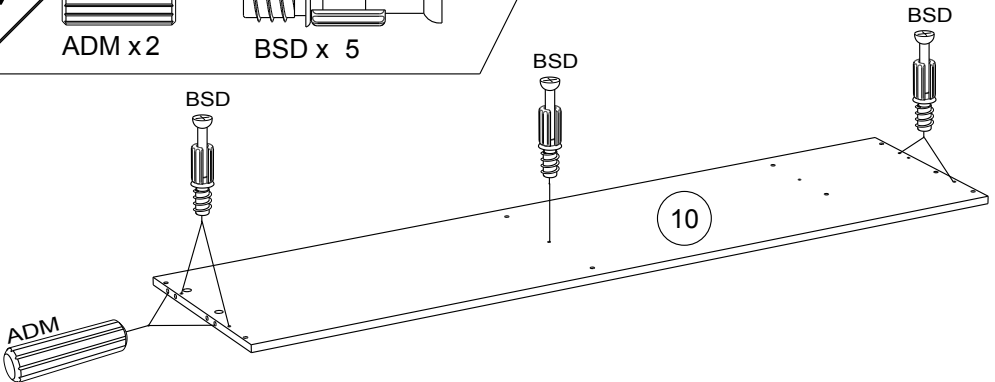
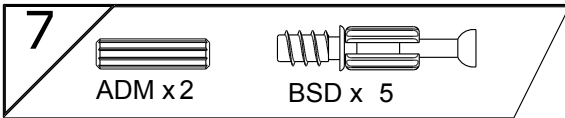
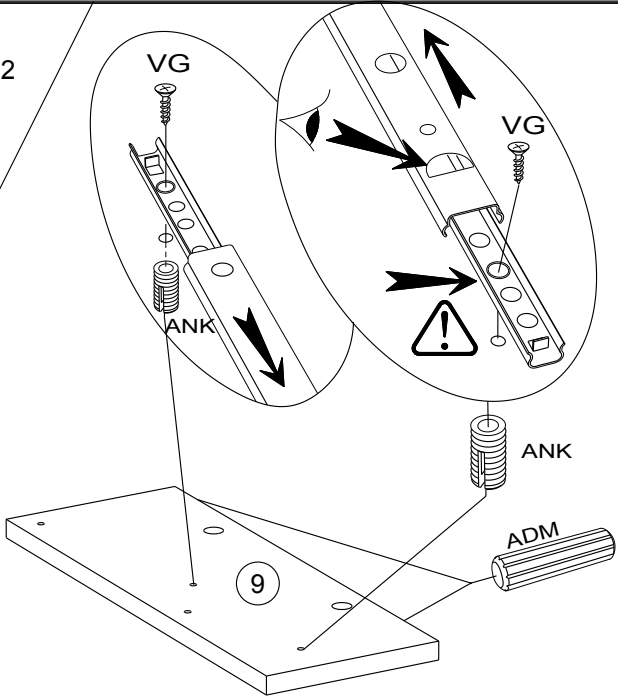
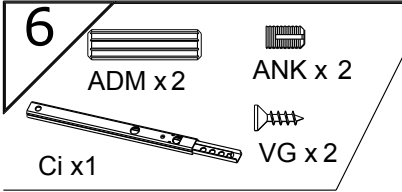
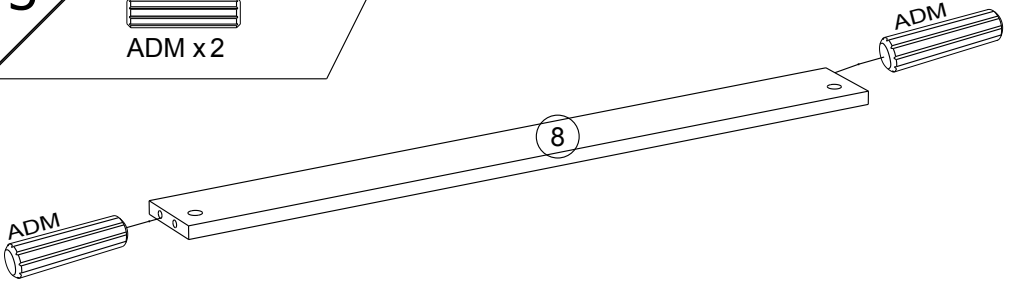
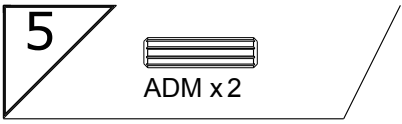

8

ADM x 2

ANK x 1

Aii x 1

ATW x 1

WE x 4

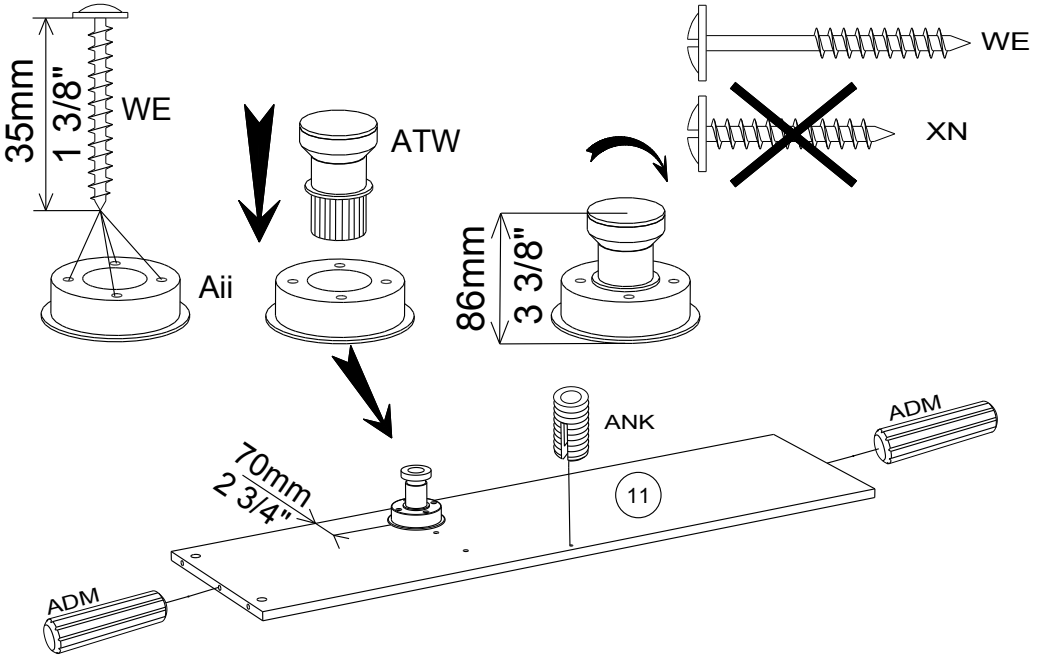

9

VG x 2

ANK x 1

ADM x 4

LN x 1

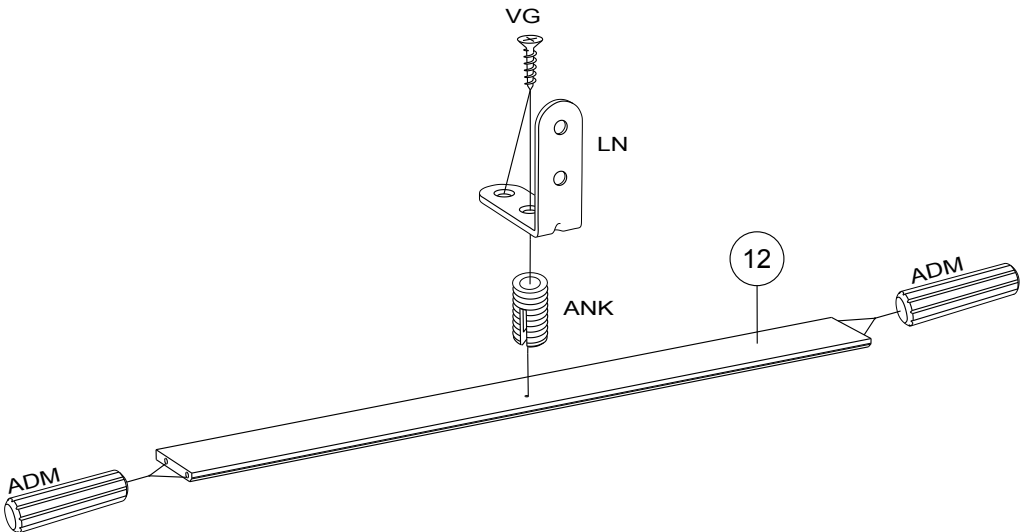

10

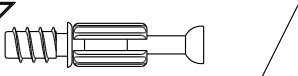

BSD x 5

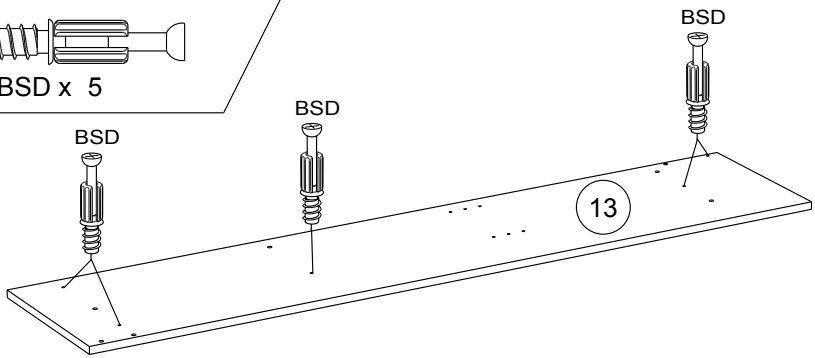

11



BSD x 3

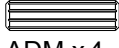

ADM x 4

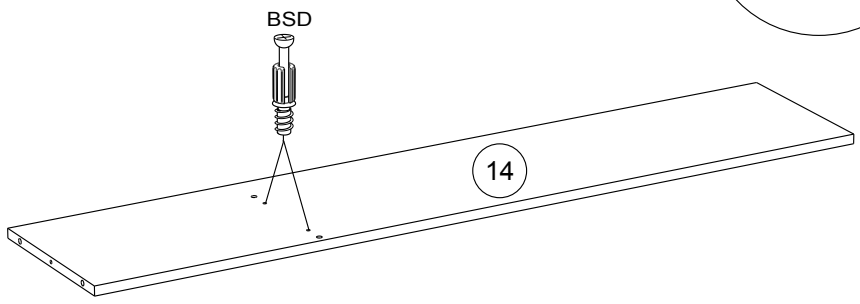
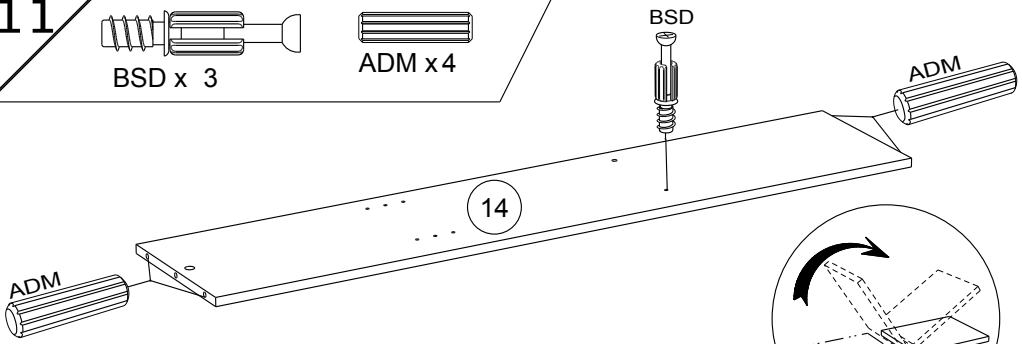

12



ADM x 2

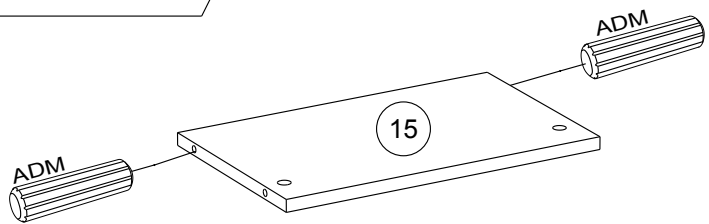

13

ADM x 7

BSD x 3

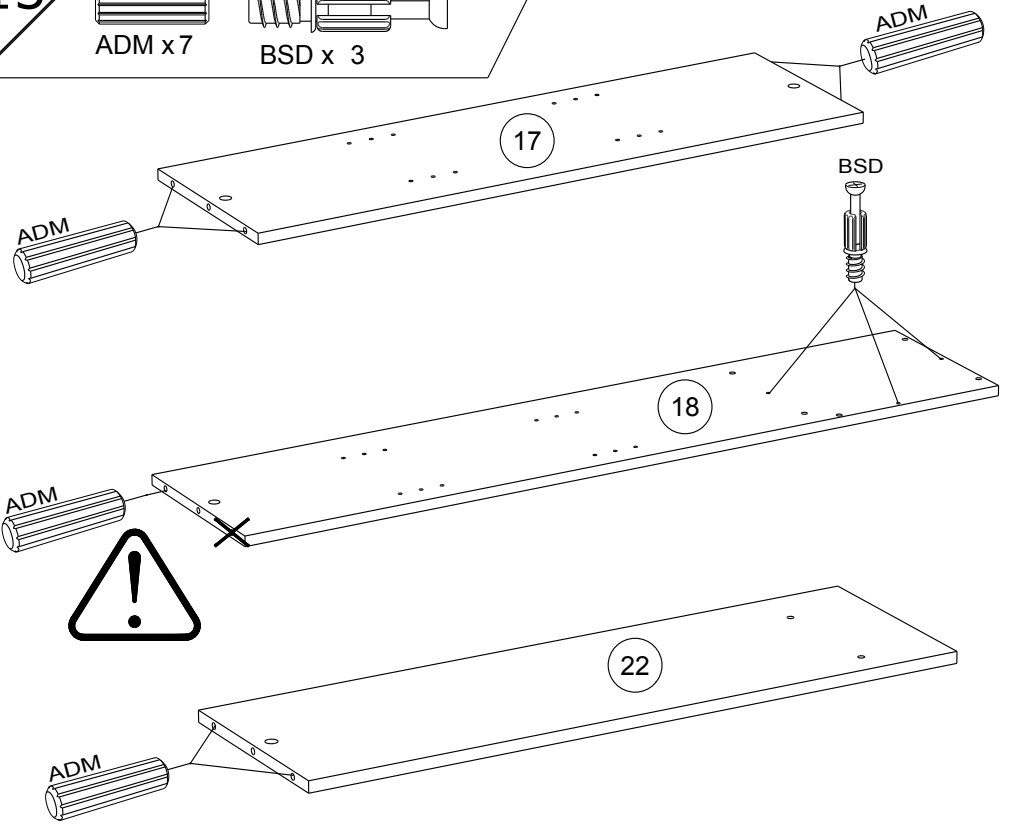

14

ADM x 6

BSD x 2

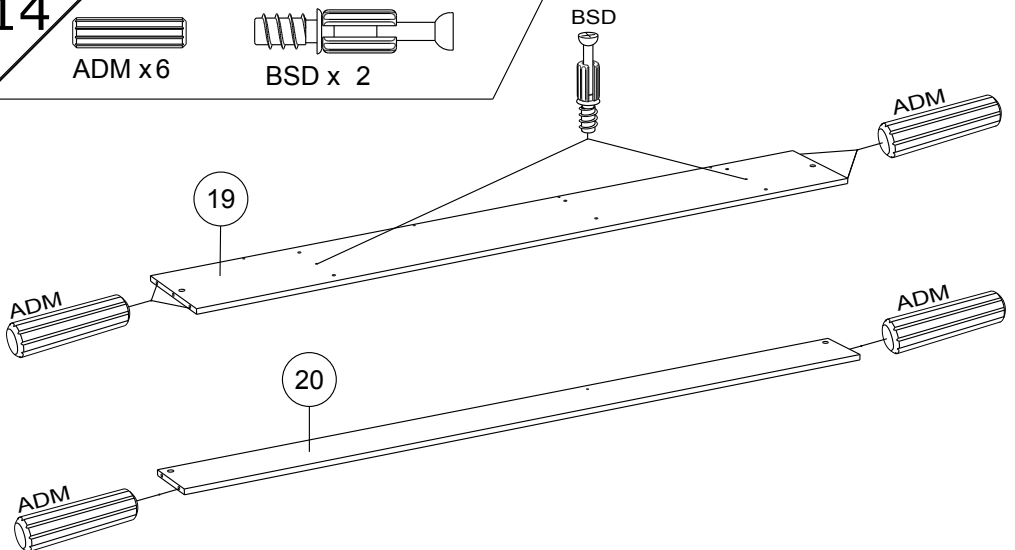

15



Ai x 3

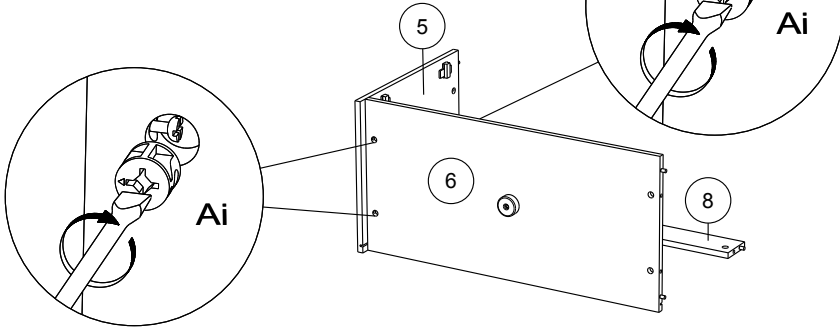

16



Ai x 3

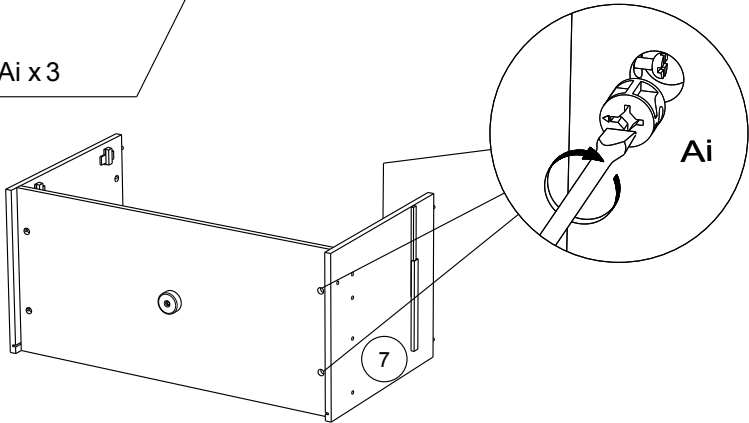

17

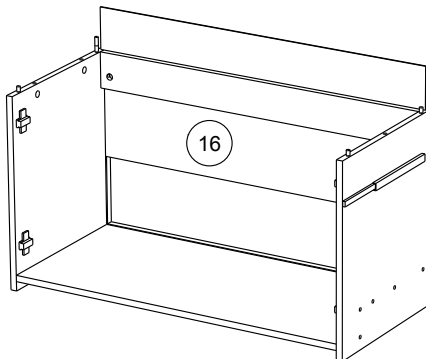

18



Ai x 3

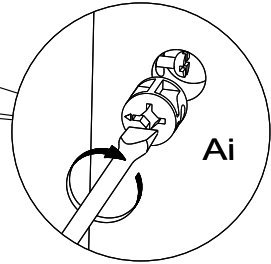
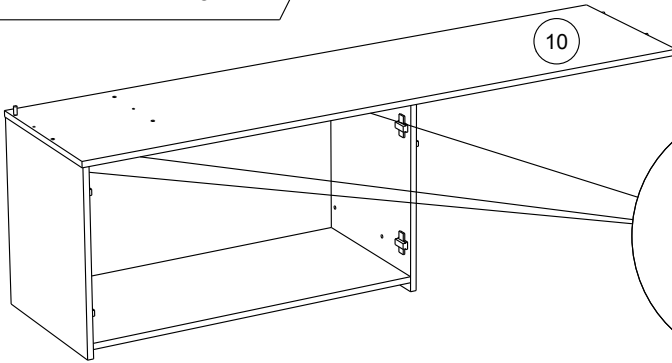

19



Ai x 2

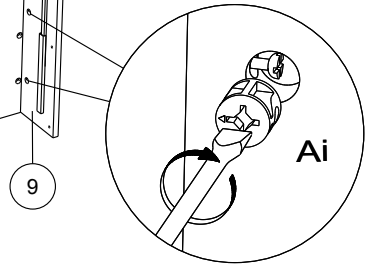
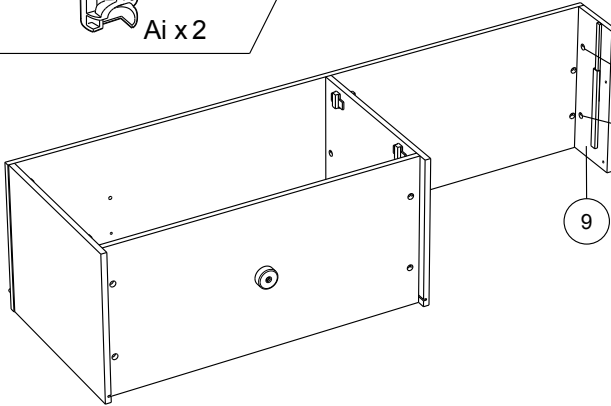

20



Ai x 2



XN x 2

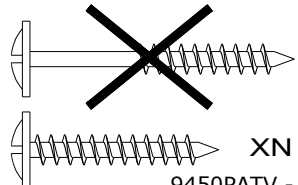
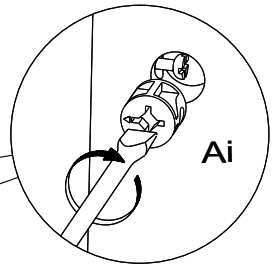
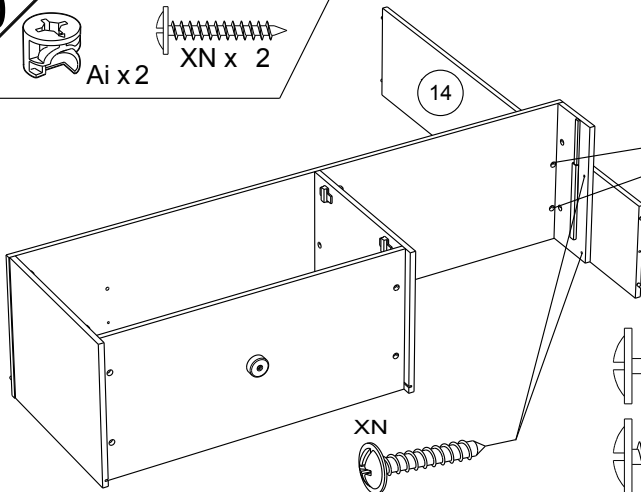

WE

XN

21

VG x 2

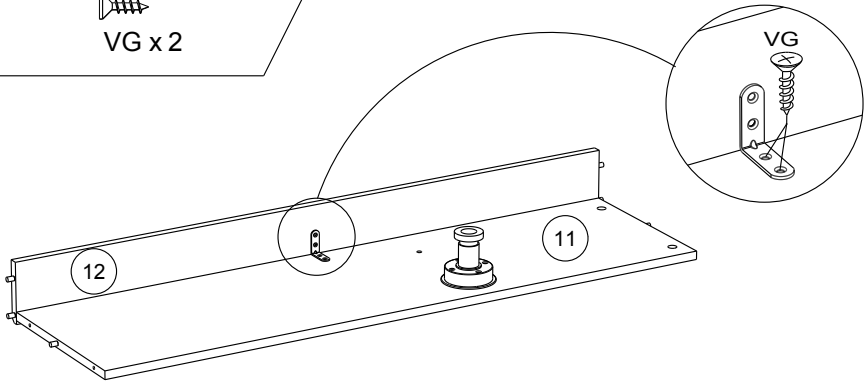

22

HW x 3

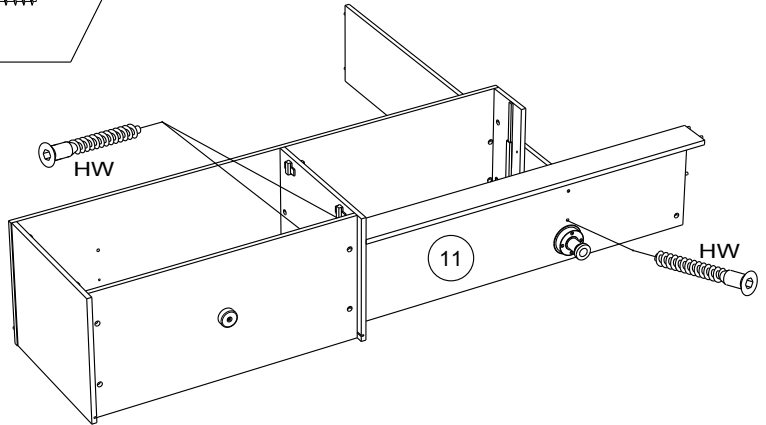

23

Ai x 1

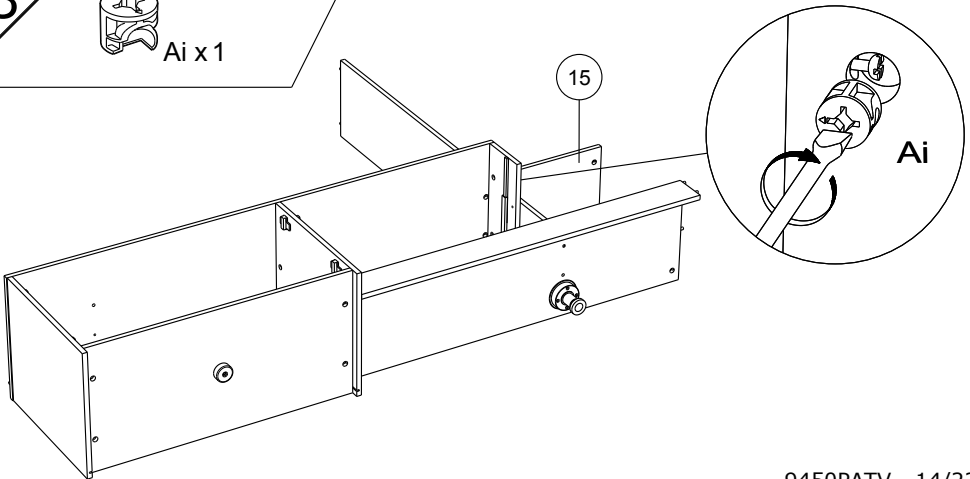

24

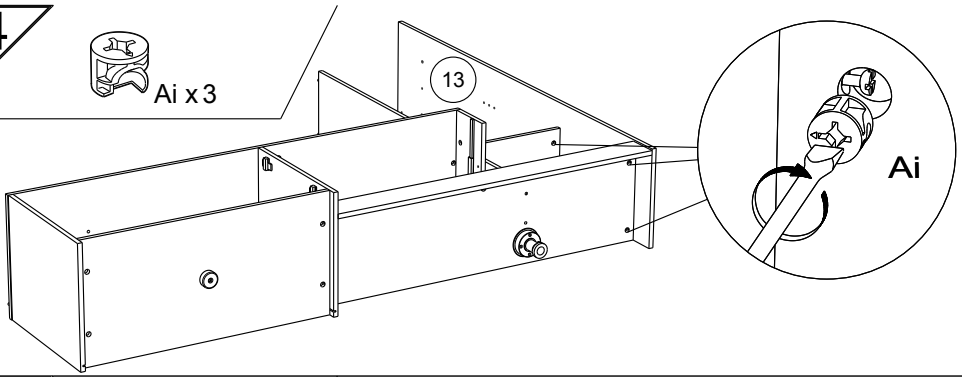

25

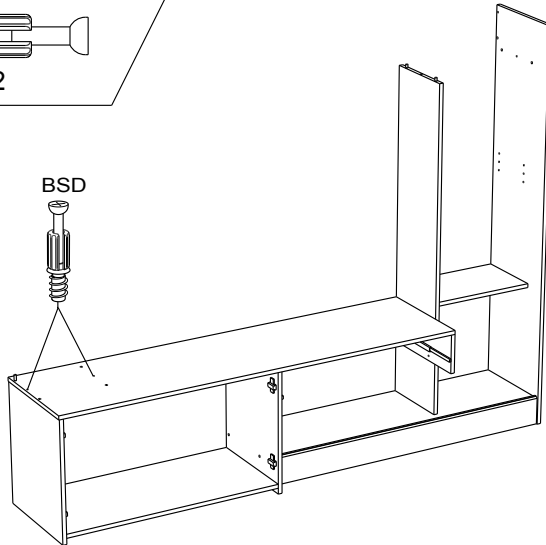
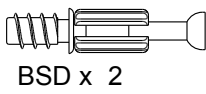

26

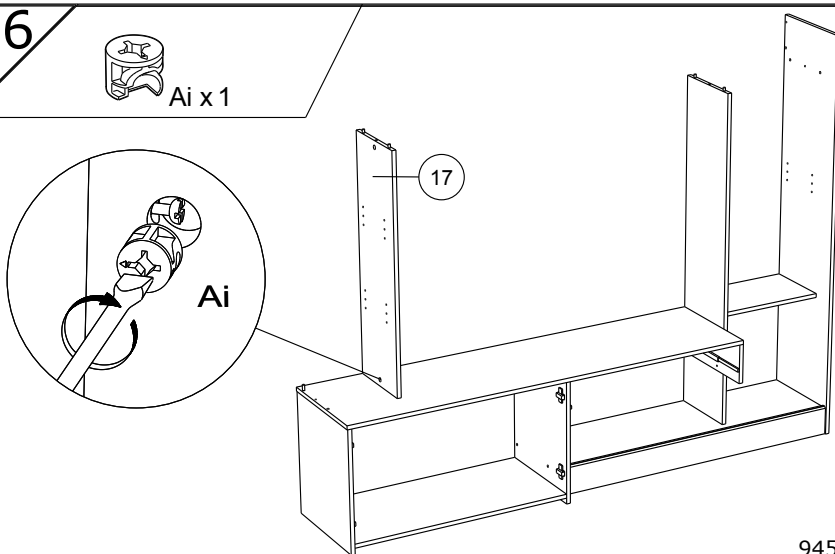

27



Ai x 3

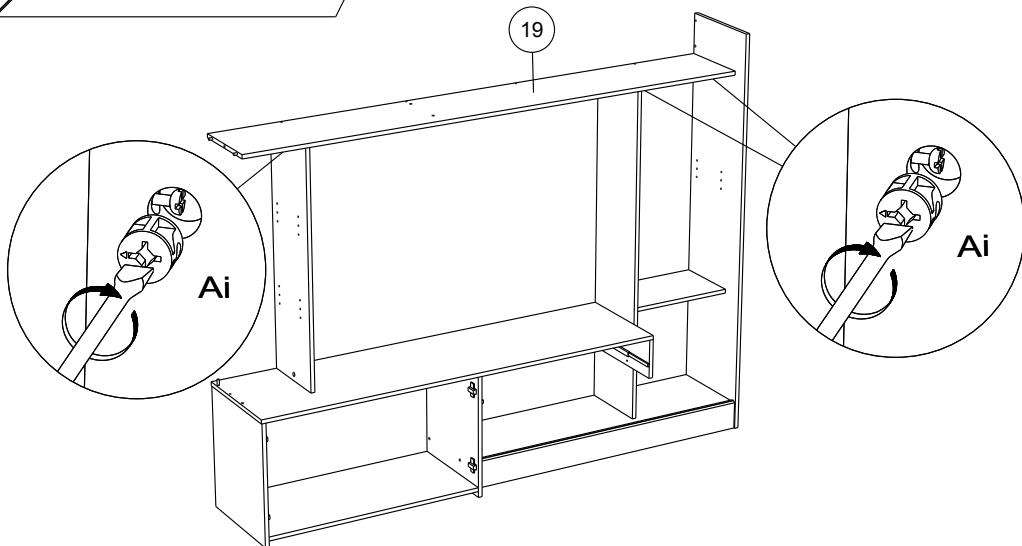

28



Ai x 1

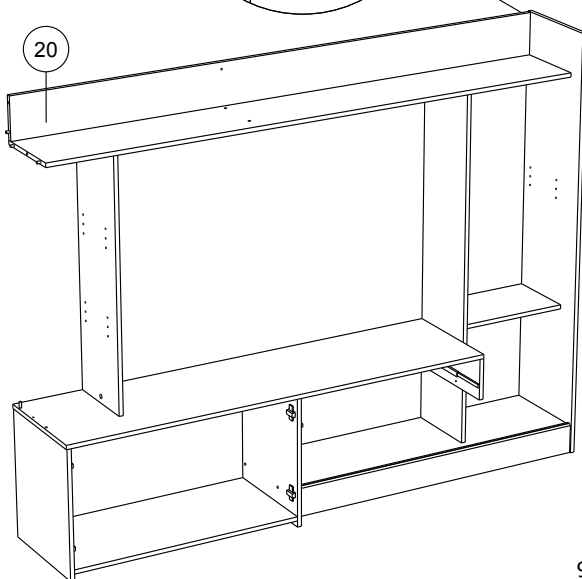
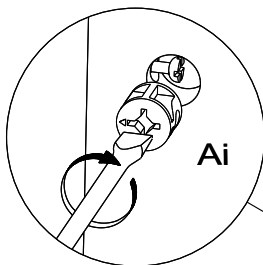

29



Ai x 3

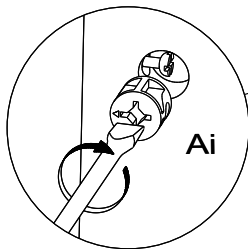

Ai

18

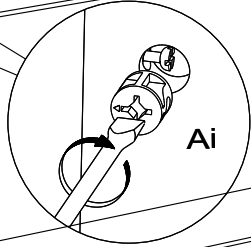

Ai

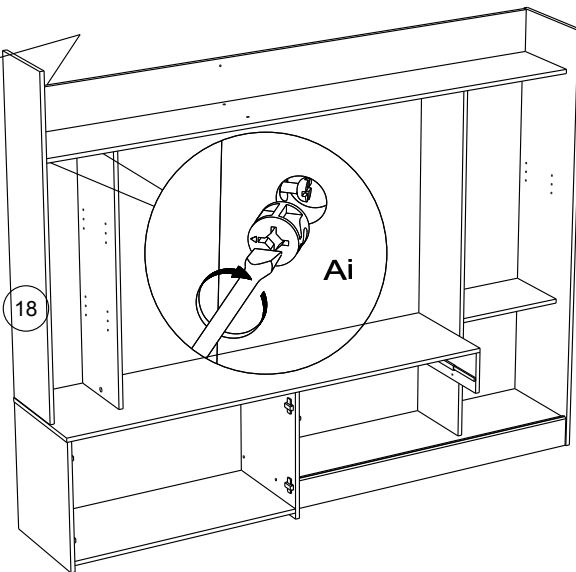

30



HW x 2

21



HW

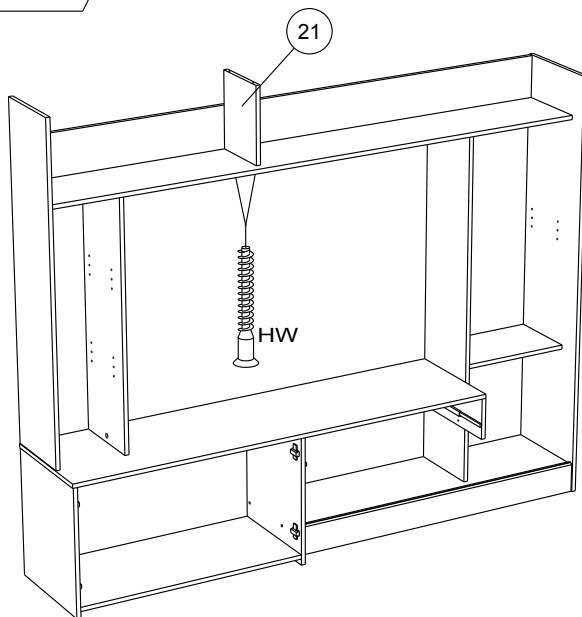

31

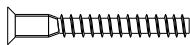

HW x 2



Ai x 1

22

HW

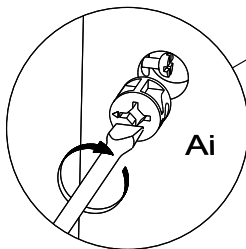

Ai

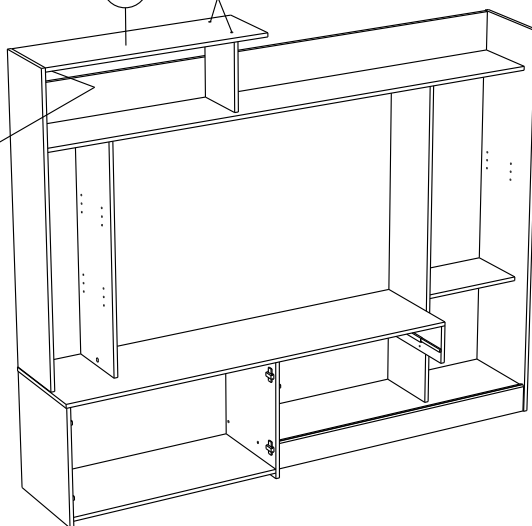

32

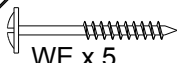

WE x 5

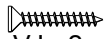

VJ x 2



EP x 2

WE

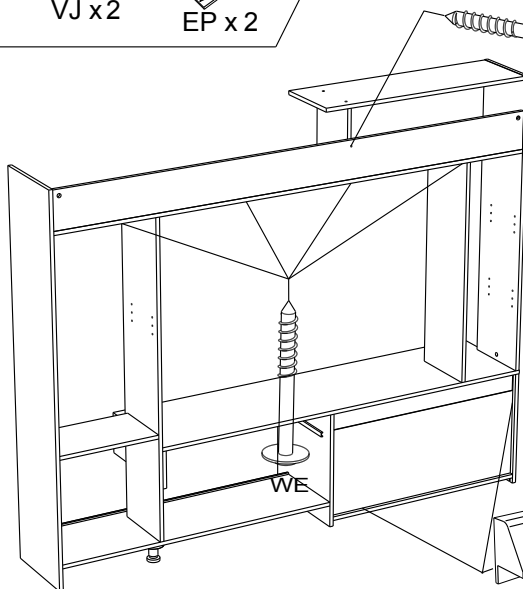

WE

EP

VJ

33



VG x 2

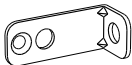

BLL x 2

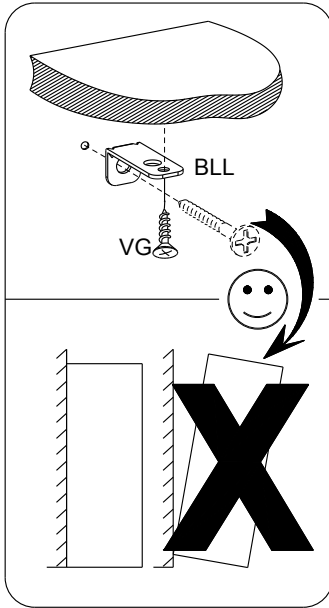

FR Pour votre sécurité : Fixation du meuble au mur

Attention, la fixation doit être réalisée par une personne compétente car cela nécessite des chevilles adaptées à la nature de votre mur.

EN For your safety: the unit should be secured to the wall.

NB this should be carried out by a competent person as you must use the right rawlplug for your type of wall.

DE Zu Ihrer Sicherheit: Befestigen Sie das Hochbett an der Wand.

Achtung: Diese Befestigung ist durch eine fachlich kompetente Person vorzunehmen. Hierfür sind für die Bauweise Ihrer Wand geeignete Dübel einzusetzen.

ES Por su seguridad: Fijar el mueble a la pared.

Advertencia: la fijación la ha de llevar a cabo por personal adecuado, ya que requiere el uso de tacos que se adapten al tipo de pared.

PT Para sua segurança: fixação do móvel ao muro

Atenção: a fixação deverá ser efetuada por pessoa habilitada, visto que são necessárias cavilhas adaptadas ao tipo de parede.

IT Avvertenza di sicurezza: il fissaggio del mobile a parete deve essere

realizzato da una persona competente, in quanto l'operazione richiede l'impiego di tasselli adatti alla natura del muro.

NL Voor uw veiligheid: bevestiging van het meubel aan de muur.

Opgelet de bevestiging moet worden uitgevoerd door een bekwam persoon daar dit voor uw type muur geschikte pluggen vereist.

CZ Z bezpečnostních důvodů: upevněte nábytek do zdi

Pozor, upevnění je třeba svěřit kompetentní osobě, neboť vyžaduje hmoždinky vhodné pro vaši zeď.

HU Az Ön biztonsága érdekében : a bútor falra rögzítése

Figyelmeztetés : a rögzítés csak megfelelő szakképítéssel rendelkező személy által végezhető el, mert a rögzítéshez a falnak megfelelő csavarokra van szükség.

PL Dla bezpieczeństwa: mocowanie mebla do ściany

Uwaga, mocowanie musi zostać wykonane przez osobę kompetentną, ponieważ wymaga to zastosowania kołków dostosowanych do rodzaju ściany.

RO Pentru securitatea dumneavoastră: fixarea mobilierului de perete

Atentie, fixarea trebuie să fie realizată de o persoană calificată, deoarece sunt necesare dispozitive de fixare adaptate caracteristicilor peretelui dumneavoastră

RU Для вашей безопасности: Крепление мебели к стене

Внимание! Крепление должно производиться опытным специалистом, т.к. для такой установки потребуются шпильки, соответствующие типу вашей стены.

SK Z bezpečnostných dôvodov: nábytok upevnite k stene.

Dajte na to, aby upevnenie vykonala kompetentná osoba, pretože pri upevňovaní sa vyžadujú koľky vhodné do materiálu, z ktorého je stena vyrobená.

TR Güvenliğiniz için: Mobilyanın duvara sabitlenmesi

Dikkat, sabitleme işlemini uzman biri tarafından yapılmalıdır çünkü bu işlem için duvarınızın malzemesine uygun dübellerin kullanılması gerekmektedir

GR Για την ασφάλειά σας : στερέωση των επίπλων στον τοίχο.

Προσοχή, η στερέωση πρέπει να γίνεται από ικανό άτομο, καθώς απαιτούνται σφίγγες προσαρμοσμένες στη φύση του τοίχου σας.

اللغة العربية

لسلامتكم الشخصية: تثبيت قطعة الأثاث على الحائط
تحذير، يجب أن يقوم شخص متخصص بعملية التثبيت على الحائط إذ أنها تتطلب اسفيننا
معينا يتوافق مع طبيعة الحائط نفسه.

34

BWW x4

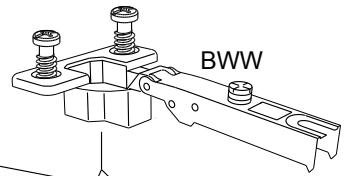
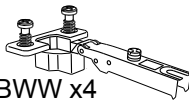

BWW

x2

23

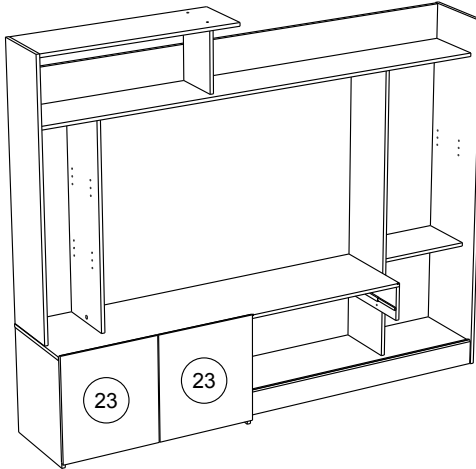
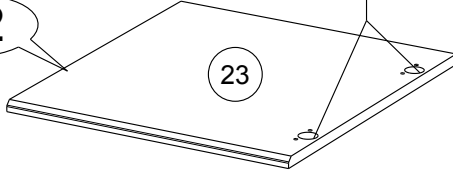

RCH-I

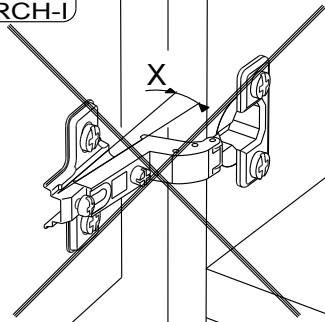

MONTAGE

- (GB) LEAFLET
- (D) AUFBAUANLEITUNG
- (E) MONTAJE
- (P) MONTAGEM
- (I) MONTAGGIO
- (NL) MONTAGE

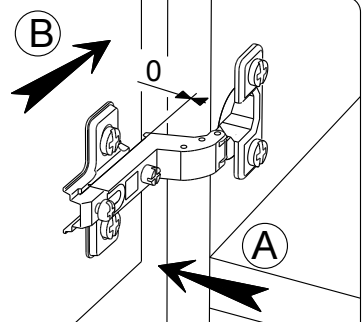

REGLAGE (GB) ADJUSTING (E) AJUSTER (I) AGGIUSTAMENTO
(D) ANPASSUNG (P) REGULACAO (NL) AFSTELLING

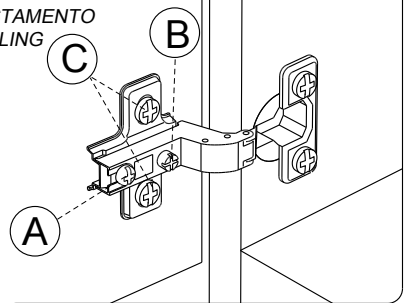
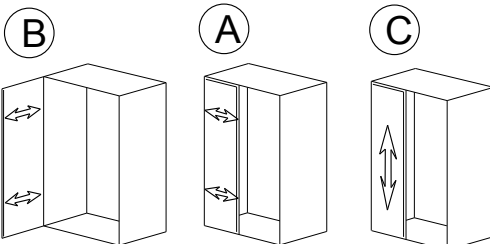

35

BWD x 12

VR x 2

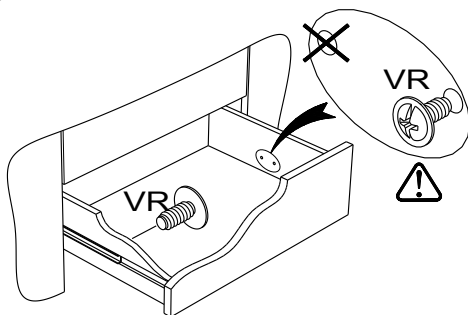
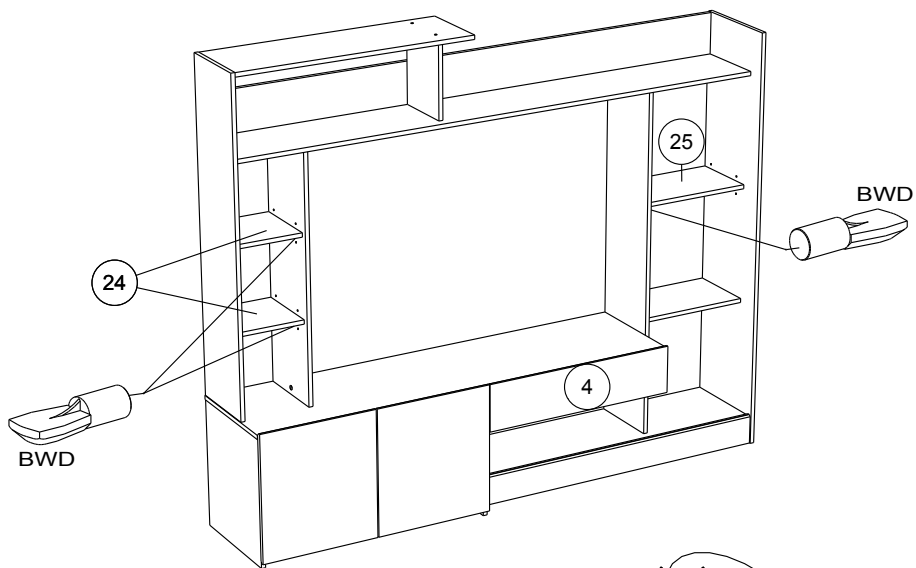
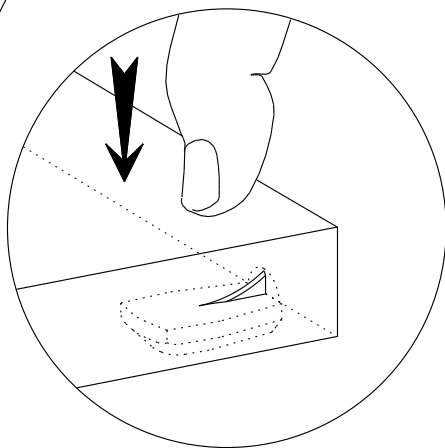

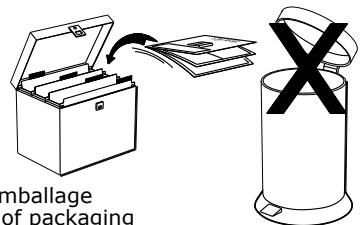
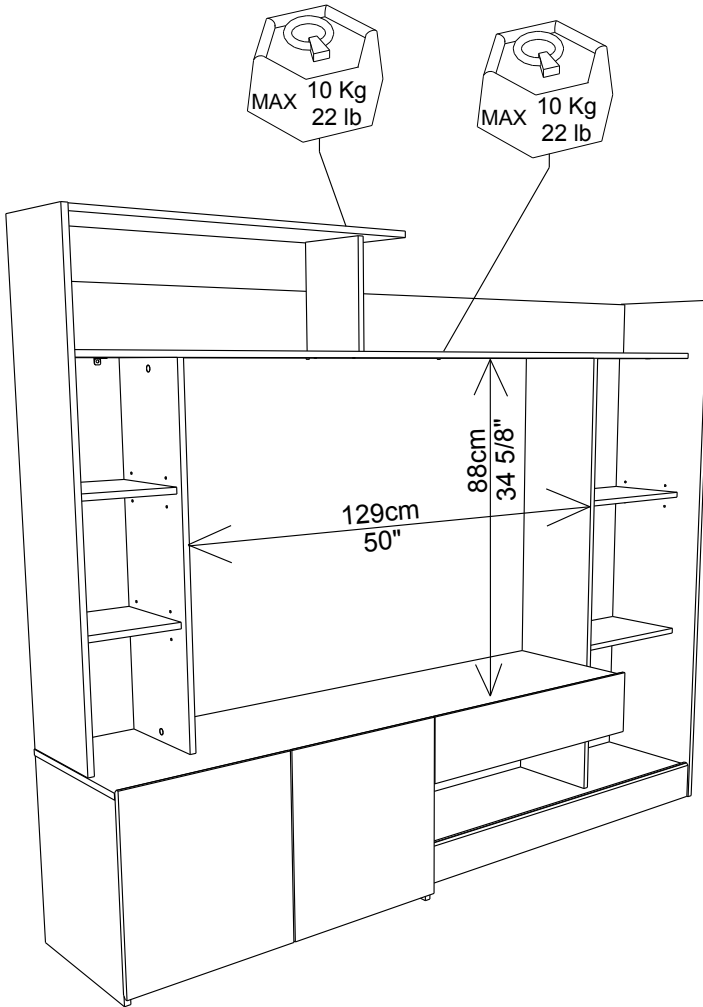

Faites un geste pour l'environnement en triant vos déchets d'emballage
Make a gesture for the environment by sorting out your waste of packaging
Machen Sie eine Bewegung für die Umwelt, ihre Verpackungsabfälle sortierend
Haga un gesto para el medio ambiente escogiendo sus residuos de embalaje