

		mm			inch		
④	x 3	412	150	15	16 1/4	5 7/8	9/16
⑳	x 3	412	392	15	16 1/4	15 7/16	9/16
⑰	x 2	478	417	15	18 13/16	16 7/16	9/16
⑨	x 1	506	417	15	19 15/16	16 7/16	9/16
⑬	x 1	512	398	15	20 3/16	15 11/16	9/16
⑫	x 2	544	398	15	21 7/16	15 11/16	9/16
⑲	x 1	933	412	15	36 11/16	16 1/4	9/16
⑦	x 2	1263	86	15	49 3/4	3 3/8	9/16
⑥	x 1	1263	538	15	49 3/4	21 3/16	9/16
⑪	x 2	1297	550	15	51 1/16	21 5/8	9/16
⑱	x 2	1412	412	15	55 9/16	16 1/4	9/16
⑩	x 1	1418	512	15	55 13/16	20 3/16	9/16
⑧	x 1	1519	544	15	59 13/16	21 7/16	9/16
⑤	x 1	1519	544	15	59 13/16	21 7/16	9/16
①	x 6	400	110	13	15 3/4	4 5/16	1/2
②	x 3	384	110	13	15 1/8	4 5/16	1/2
③	x 3	399	394	3	15 11/16	15 1/2	1/8
⑮	x 1	1277	406	3	50 1/4	16	1/8
⑭	x 1	1430	432	3	56 1/4	17	1/8
⑯	x 1	1430	846	3	56 1/4	33 5/16	1/8

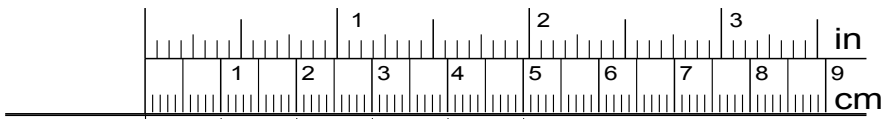

HW x 16

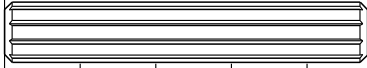

AB x 6

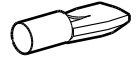

BWD x 8

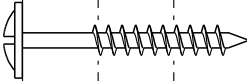

WH x 18



EP x 5



FA x 4

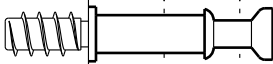

BWC x 12

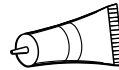

CF x 2



Ai x 12



ADU x 12

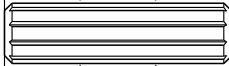

ADM x 32



GZ x 2



WA x 6



VJ x 5

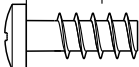

BWT x 56



LN x 4



HV x 1



VE x 6

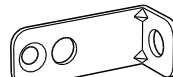

BLL x 1

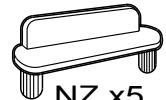

NZ x 5

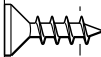

VG x 31



ANK x 20

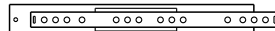

Ci x 6



DC x 1

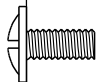

VR x 6



BWV x 14

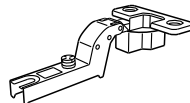

BWY x 14

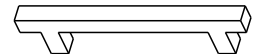

X9

3

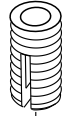
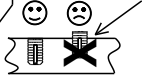
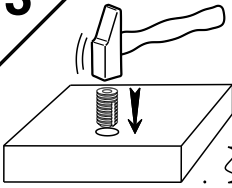

ANK X4

ADM

6

ADM

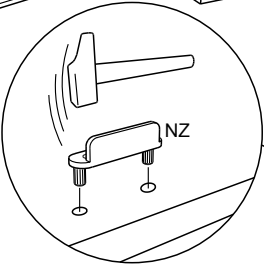

6

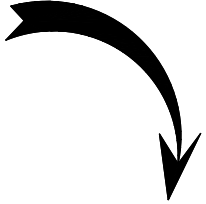

4



ANK X2

7

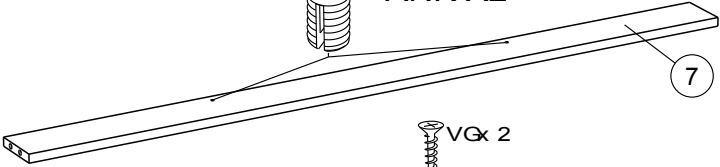

X2



VGx 2

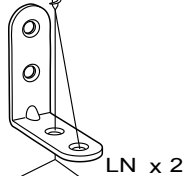

LN x 2

ADMx 2

7



5

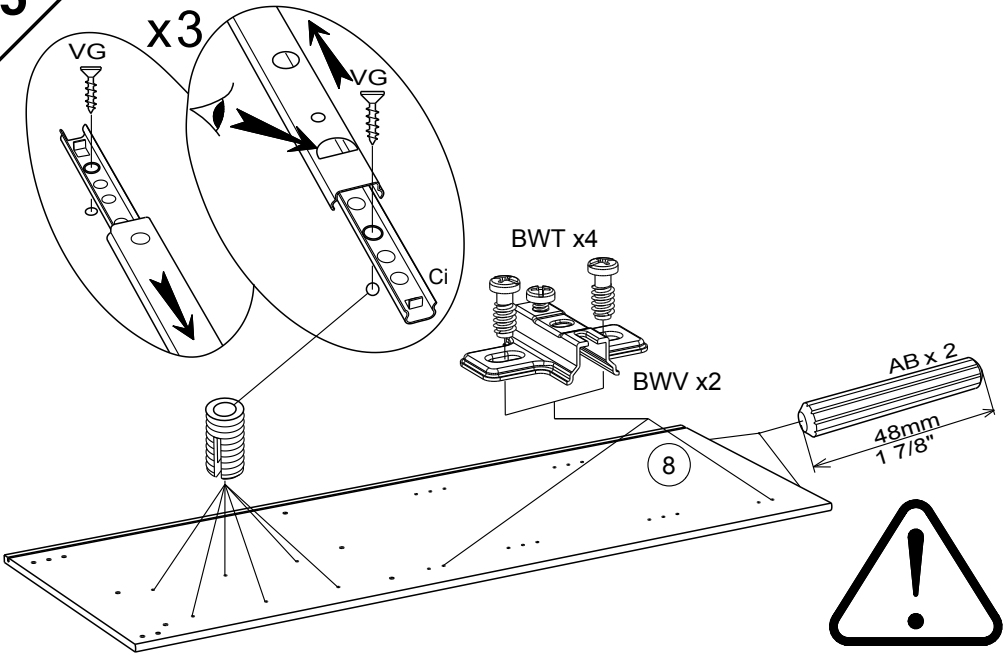

6

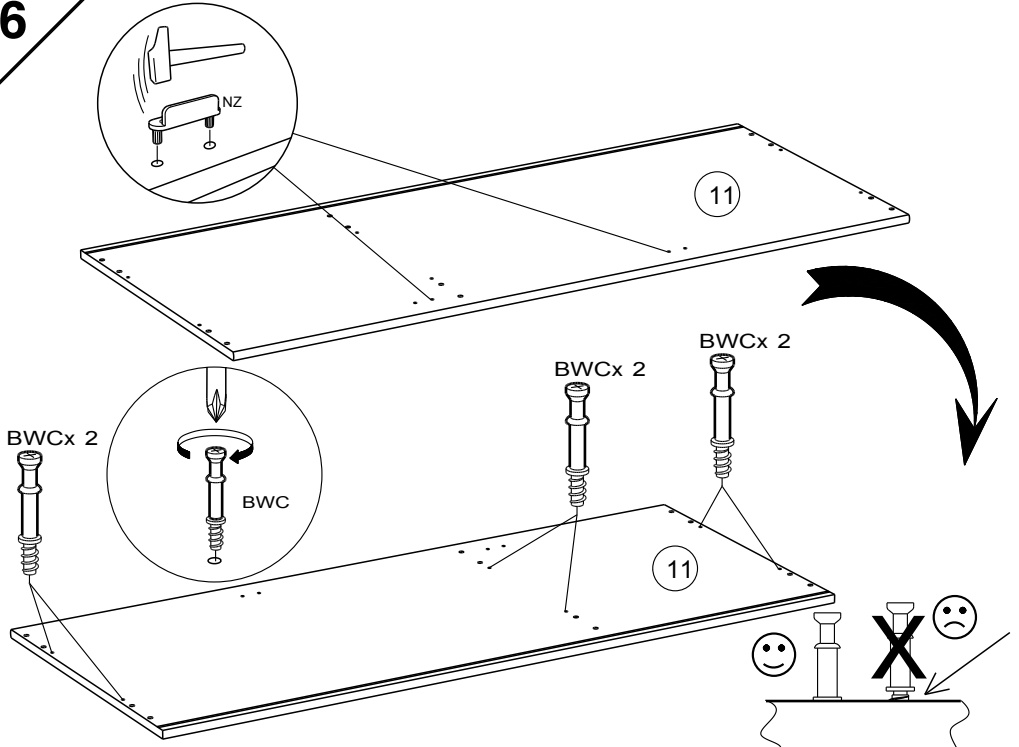

7

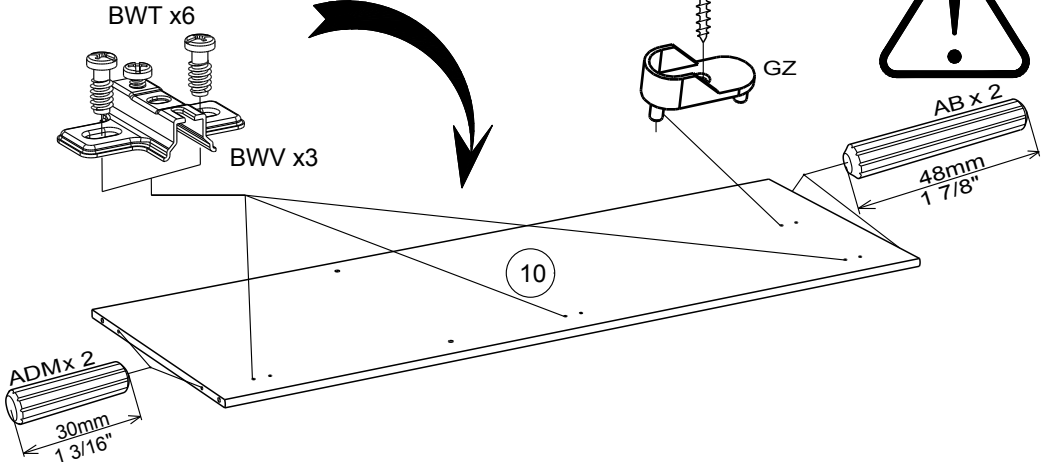
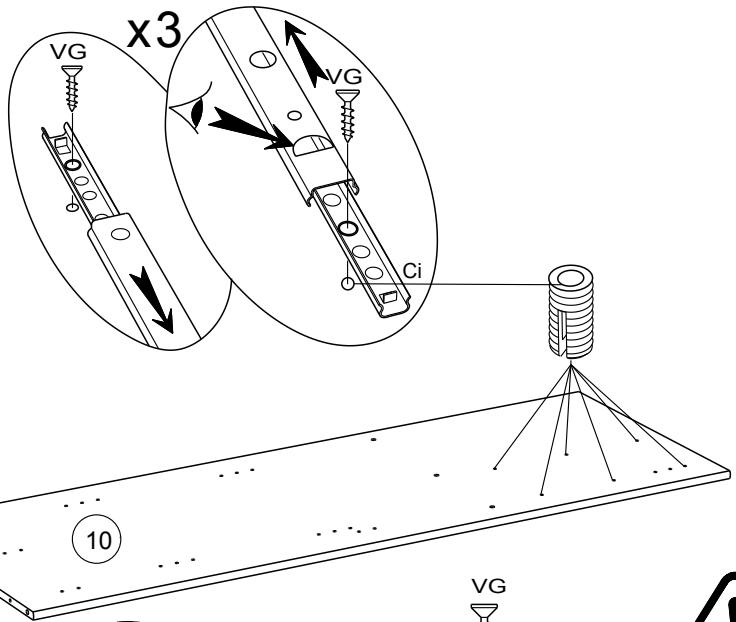

8

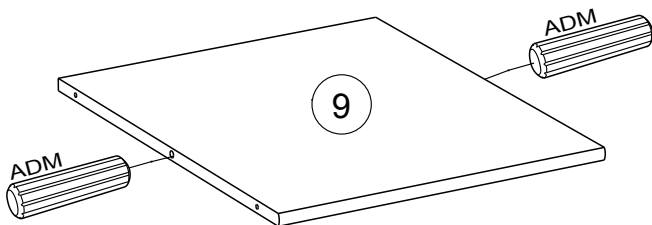

9

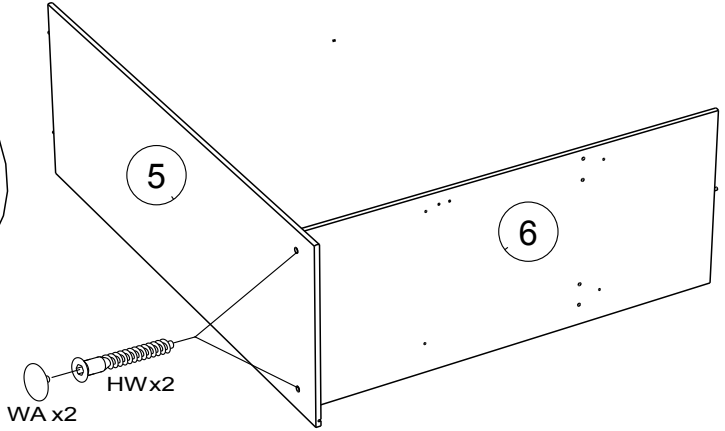
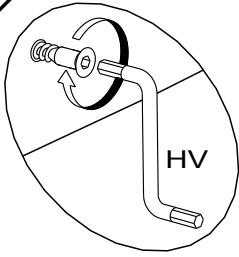

10

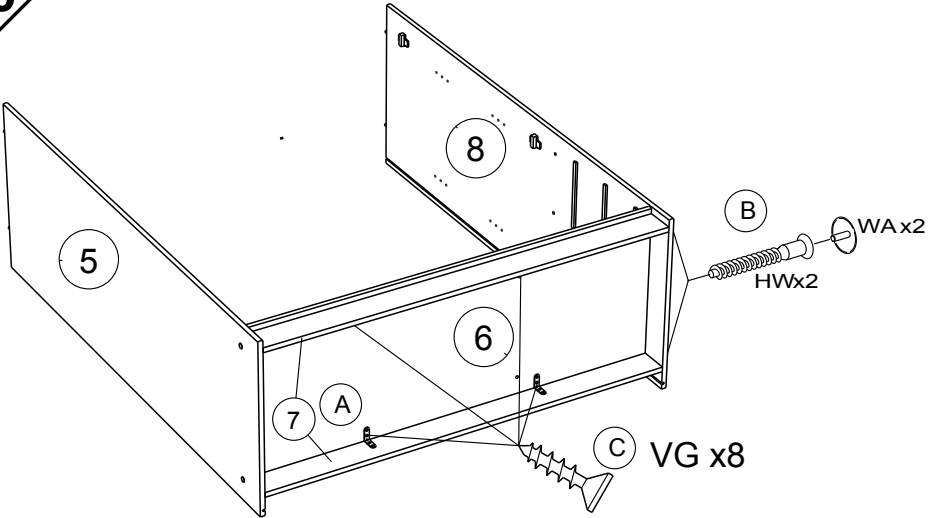

11

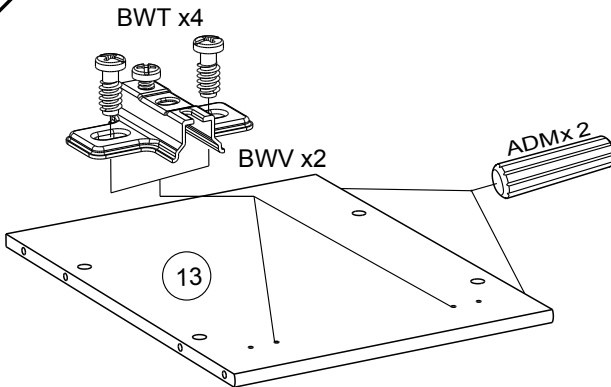

12

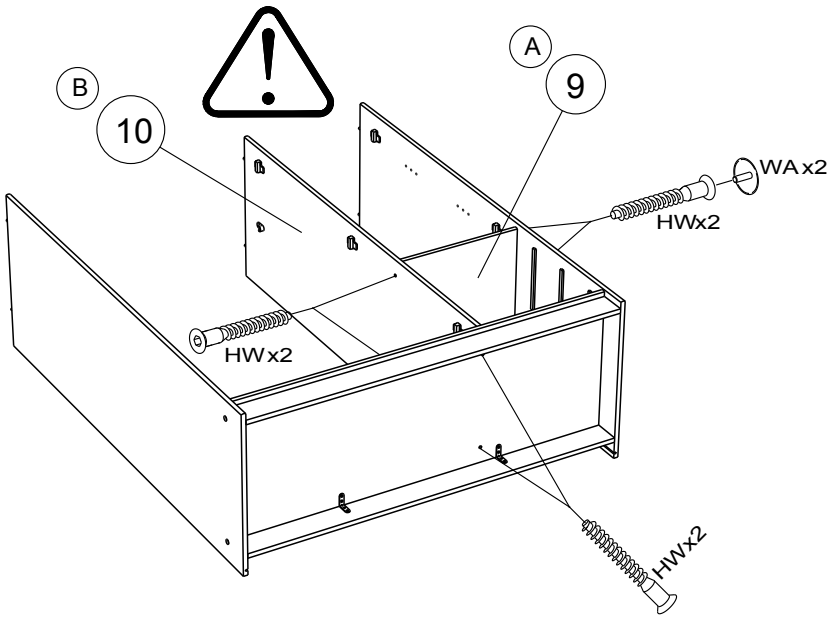

13

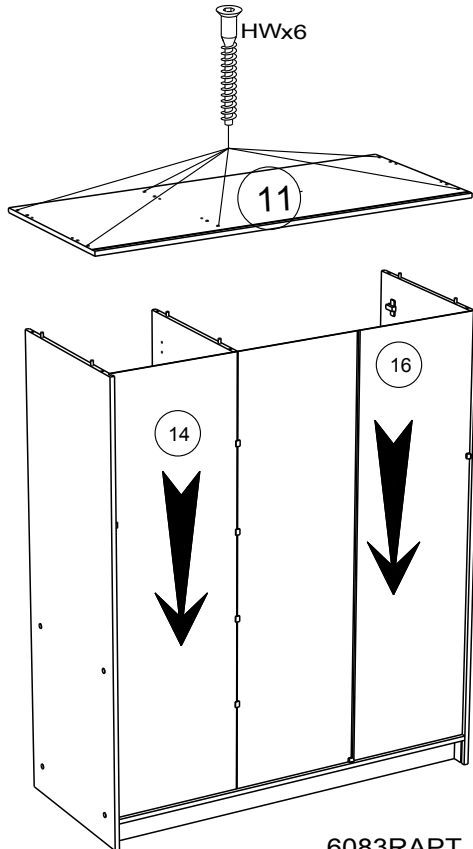

14

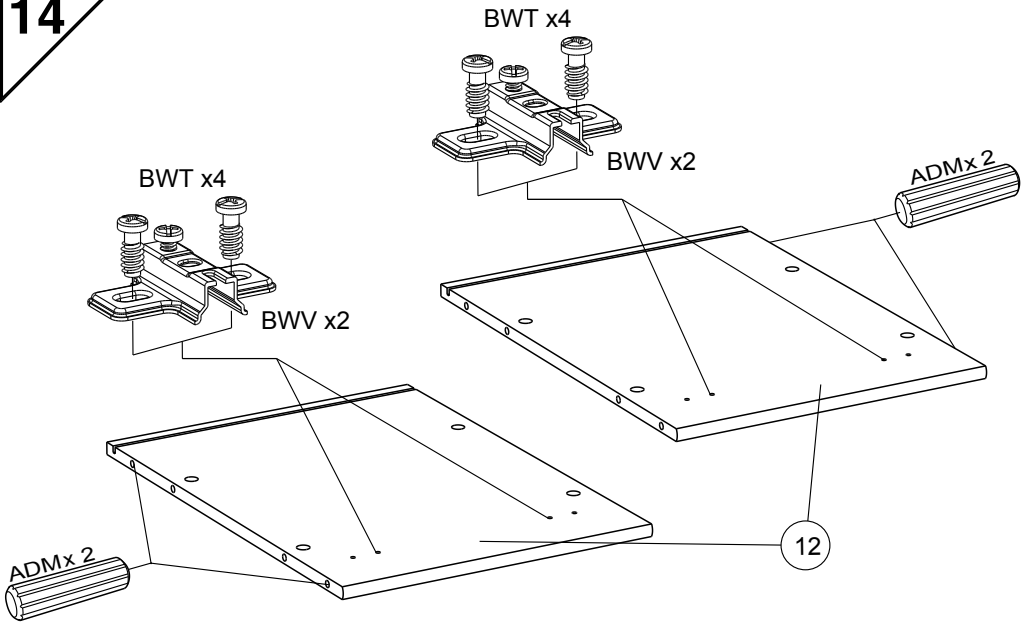

15

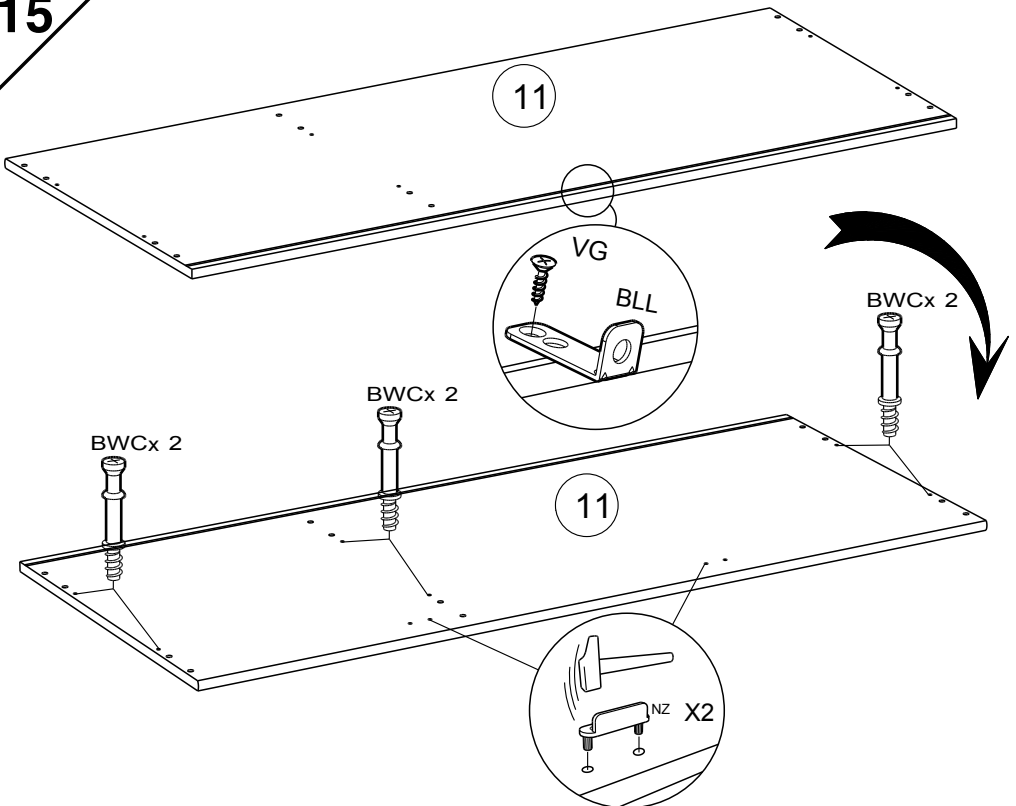

16

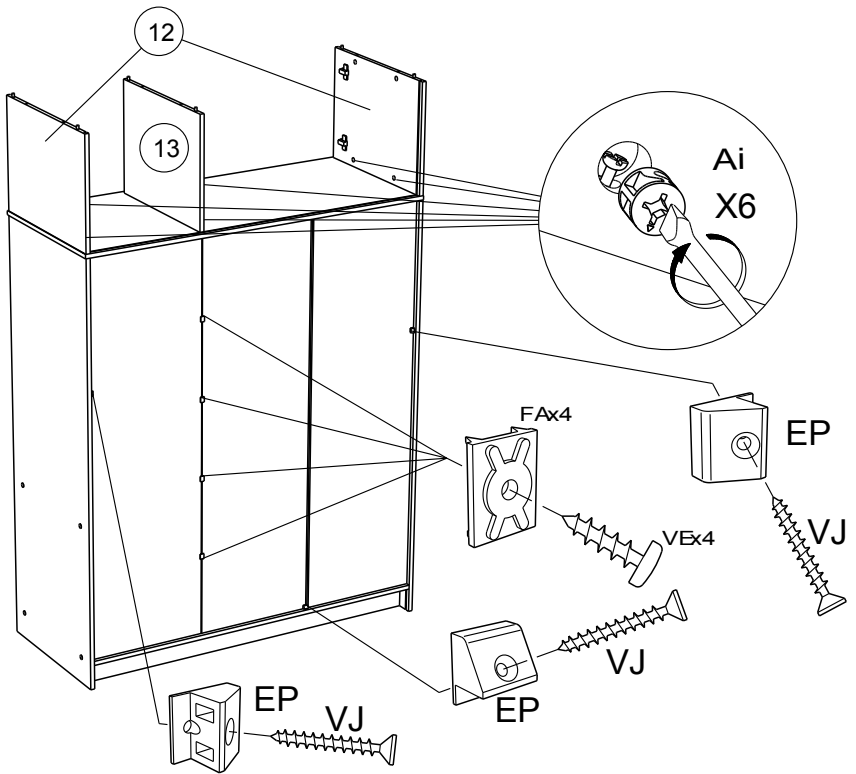

17

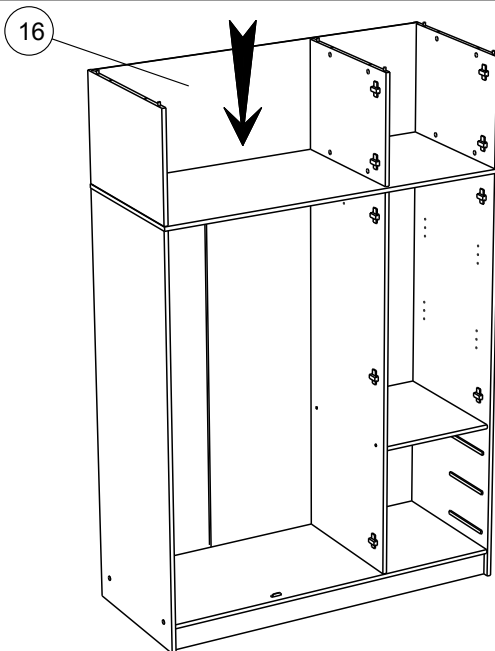

18

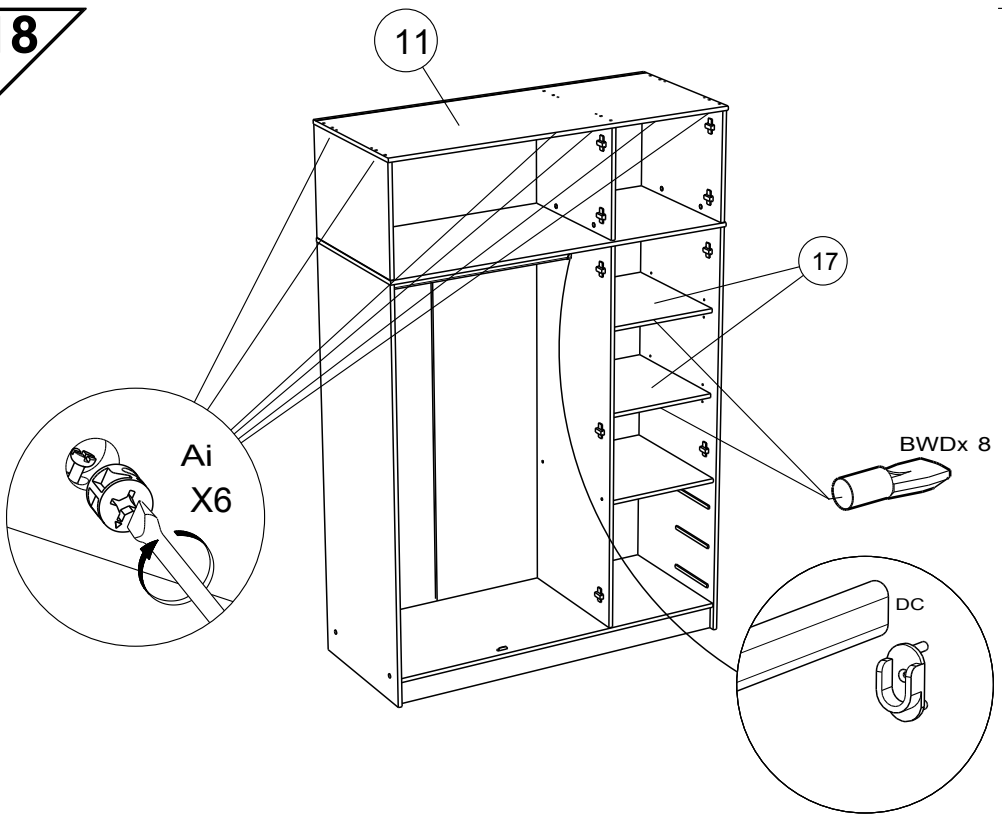

19

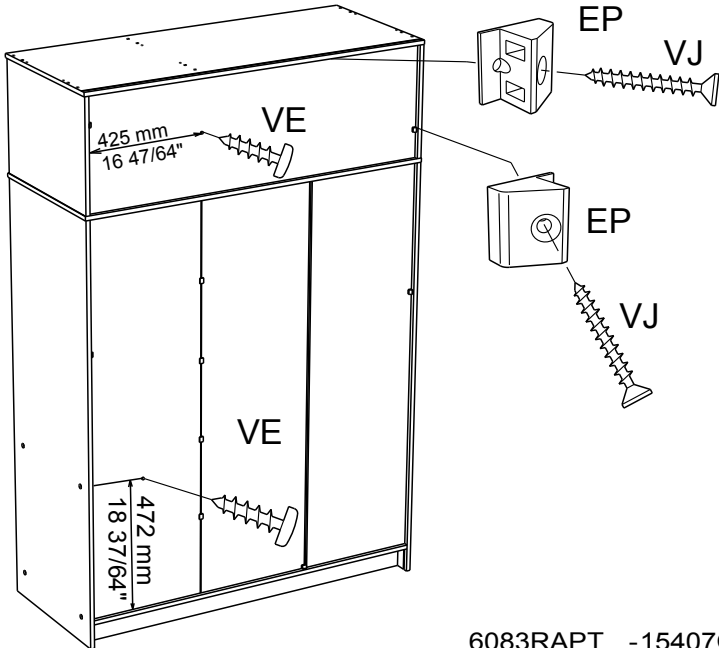

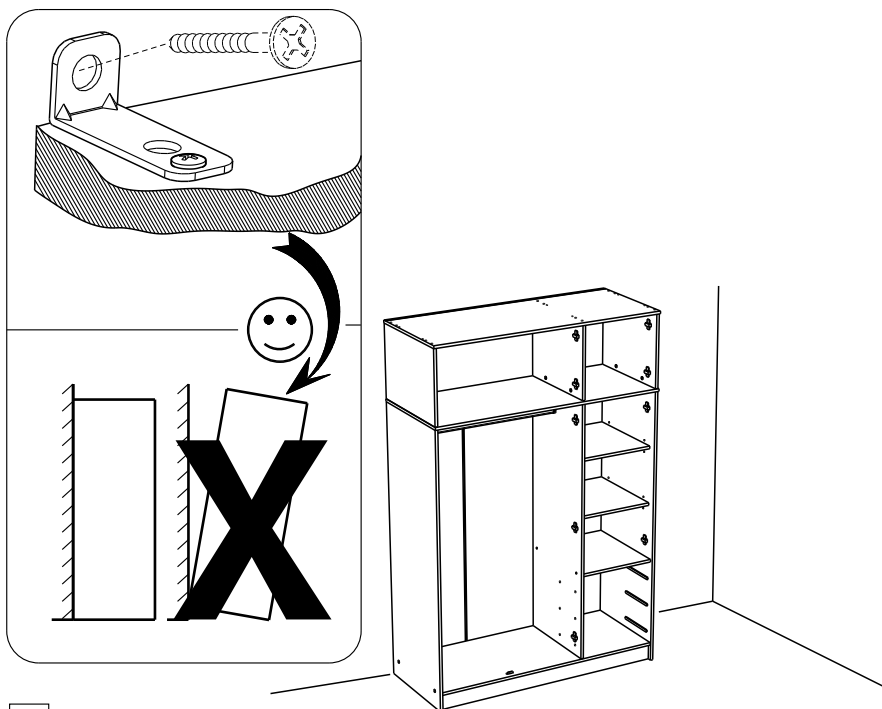

- FR** Pour votre sécurité : Fixation du meuble au mur
Attention, la fixation doit être réalisée par une personne compétente car cela nécessite des chevilles adaptées à la nature de votre mur.
- GB** For your own safety: attach the furniture to the wall
Important! The furniture must be attached by a qualified person using dowels that are suited to the type of wall.
- D** Für Ihre Sicherheit: Befestigung des Möbelstücks an der Wand
Achtung, die Befestigung muss von einem Fachmann vorgenommen werden, weil sie an die Wand angepasste Dübel erfordert.
- E** Para su seguridad: Fijación del mueble a la pared
¡Ojo! La fijación deberá llevarla a cabo una persona competente ya que necesitará unos tacos adaptados a tipo de pared.
- PT** Para a sua segurança: Fixação do móvel na parede
Atenção, a fixação deve ser efectuada por uma pessoa competente, pois exige a utilização de cavilhas adaptadas à natureza da parede.
- I** Per la vostra sicurezza: fissaggio del mobile alla parete.
Nota bene, il fissaggio deve essere eseguito da personale specializzato, poiché l'utilizzo di tasselli adattati alla parete.
- NL** Voor uw veiligheid: bevestiging van het meubel aan de muur.
Let op, de bevestiging moet worden uitgevoerd door een bevoegd persoon, want hiervoor zijn pluggen nodig die specifiek geschikt zijn voor de betreffende muur.

X3

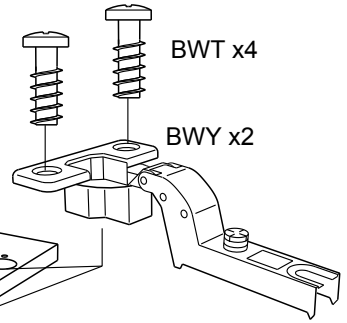
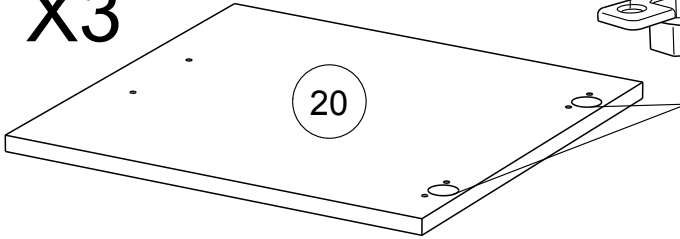

X2

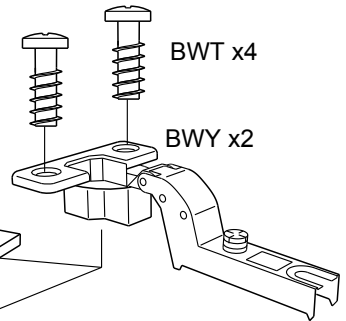
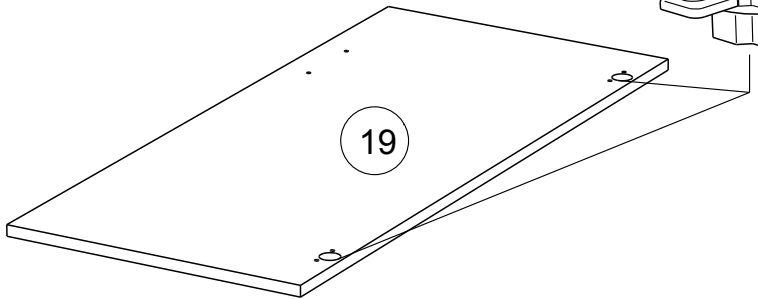
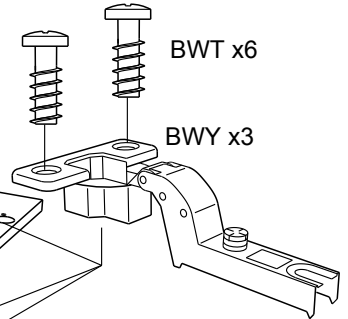
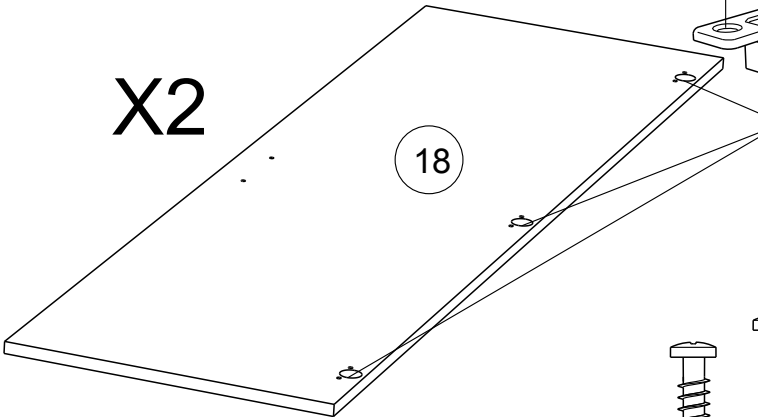

22

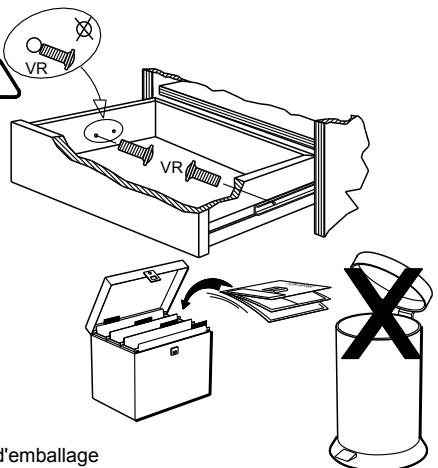
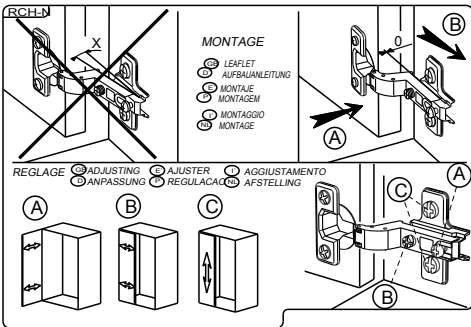
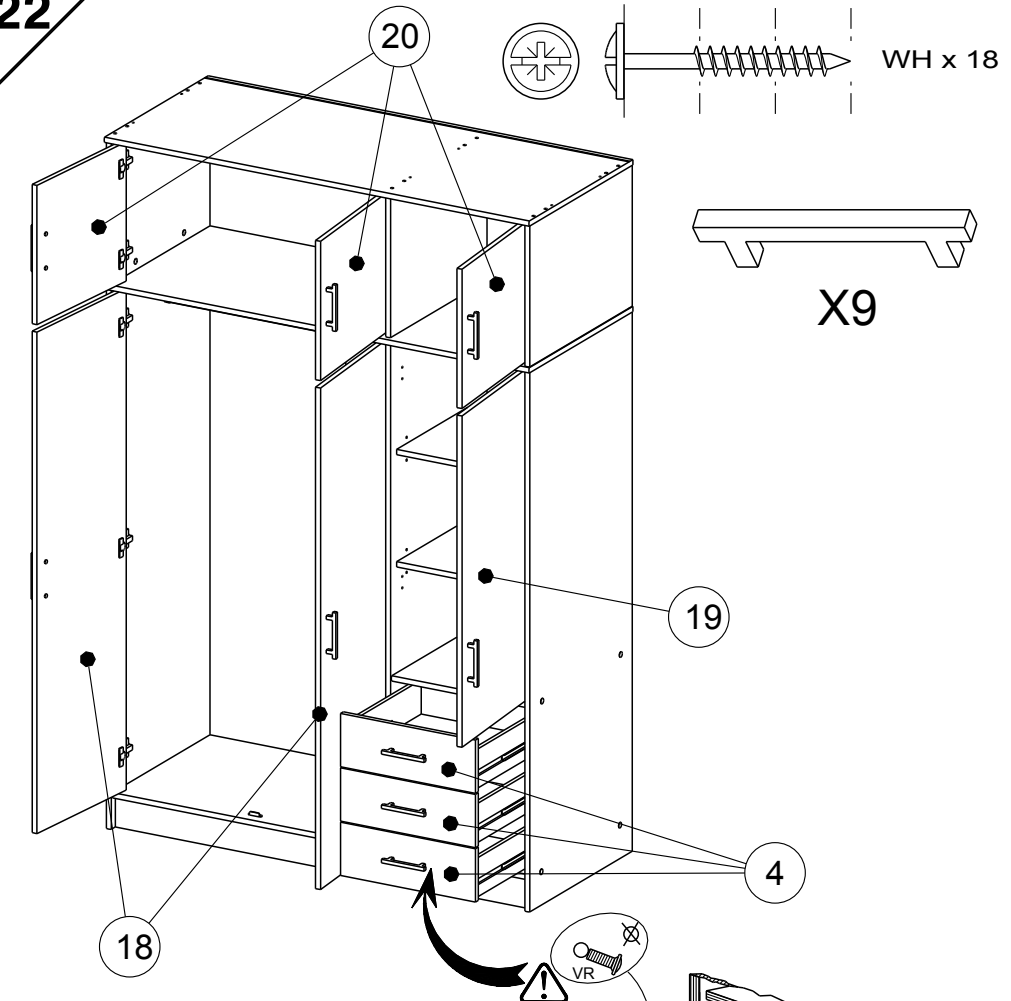

Faites un geste pour l'environnement en triant vos déchets d'emballage
 Make a gesture for the environment by sorting out your waste of packaging
 Machen Sie eine Bewegung für die Umwelt, ihre Verpackungsabfälle sortierend
 Haga un gesto para el medio ambiente escogiendo sus residuos de embalaje