

6024RAPT

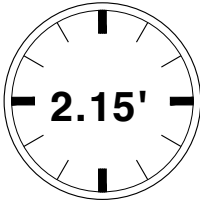

GREEN
way



202.5cm
79 3/4 "

176 cm
69 1/4 "

55 cm
21 3/4 "

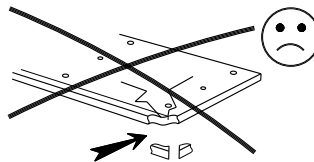
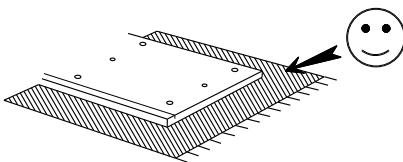
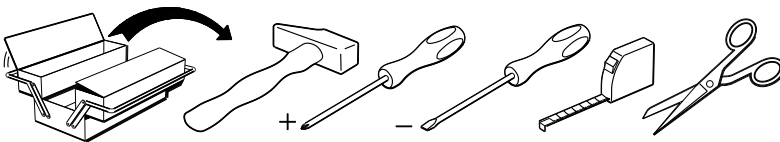

Gamme : INFINITY



Parisot

www.parisot.com

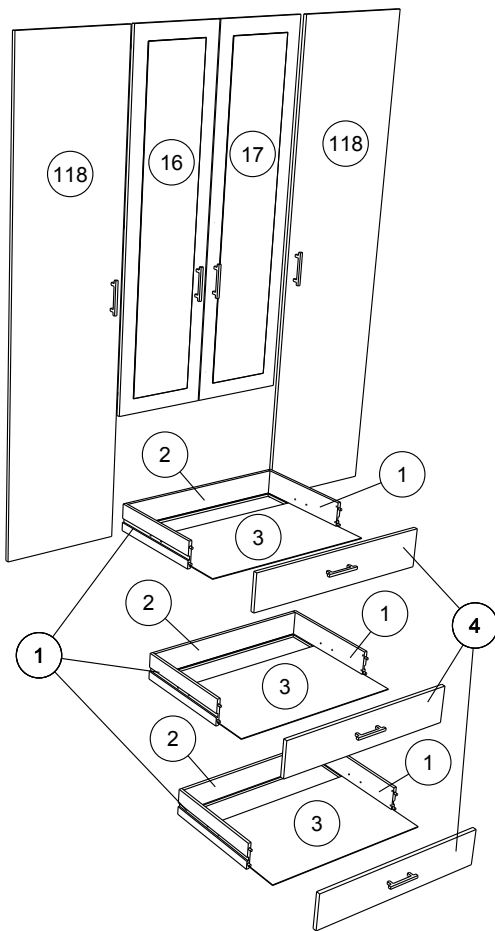
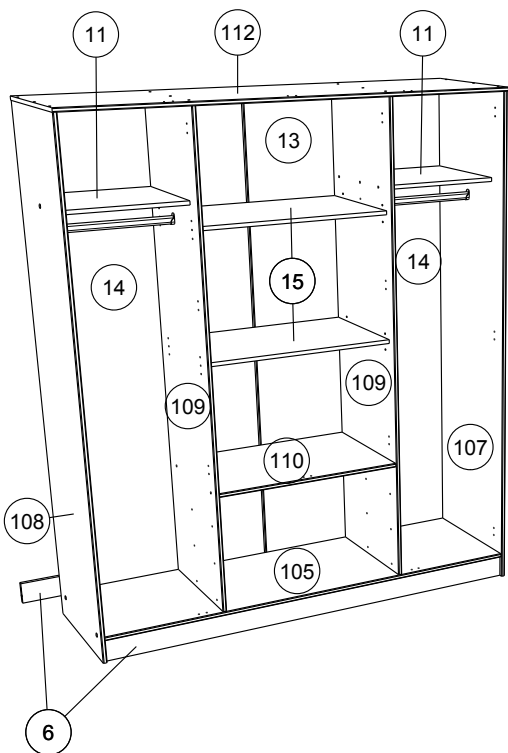

		mm			inch		
(11)	x 2	471	430	15	18 9/16	16 15/16	9/16
(4)	x 3	746	150	15	29 3/8	5 7/8	9/16
(15)	x 2	750	468	15	29 1/2	18 7/16	9/16
(110)	x 1	750	505	15	29 1/2	19 7/8	9/16
(17)	x 1	1419	371	19	55 7/8	14 5/8	3/4
(16)	x 1	1419	371	19	55 7/8	14 5/8	3/4
(6)	x 2	1722	86	15	67 13/16	3 3/8	9/16
(105)	x 1	1722	537	15	67 13/16	21 1/8	9/16
(112)	x 1	1756	547	15	69 1/8	21 9/16	9/16
(118)	x 2	1898	466	15	74 3/4	18 3/8	9/16
(109)	x 2	1904	511	15	74 15/16	20 1/8	9/16
(107)	x 1	2006	543	15	78 15/16	21 3/8	9/16
(108)	x 1	2006	543	15	78 15/16	21 3/8	9/16
(1)	x 6	400	110	13	15 3/4	4 5/16	1/2
(2)	x 3	699	110	13	27 1/2	4 5/16	1/2
(3)	x 3	709	399	3	27 15/16	15 11/16	1/8
(14)	x 2	1920	486	3	75 9/16	19 1/8	1/8
(13)	x 1	1920	765	3	75 9/16	30 1/8	1/8

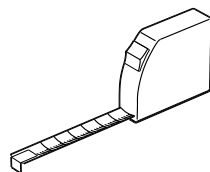

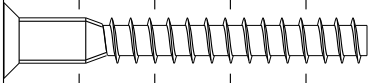
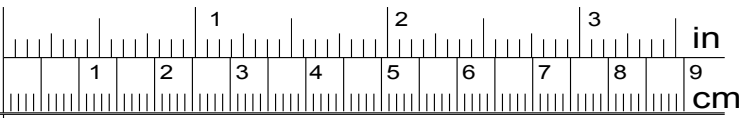

HW x 20



EP x 9

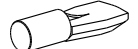

BWD x 8

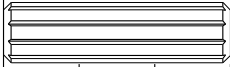

ADM x 40



WA x 6

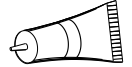

CF x 2



ADU x 12

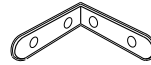

LN x 6

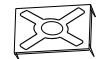

FA x 10

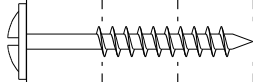

WH x 14



HV x 1

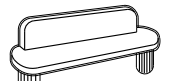

NZ x 6

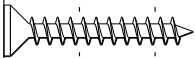

VJ x 19



GZ x 4

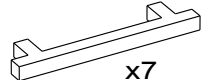

x7

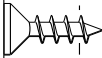

VG x 34

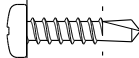

BRL x 12

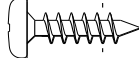

VE x 4

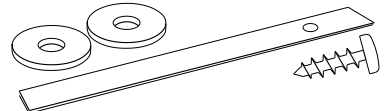

BIP x 1

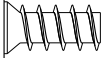

BWF x 12

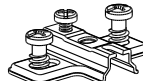

BWU x 12

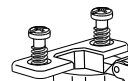

BWY x 12



ANK x 12



DC x 2



AFM x 3



AFN x 3



AFK x 3



AFL x 3

1

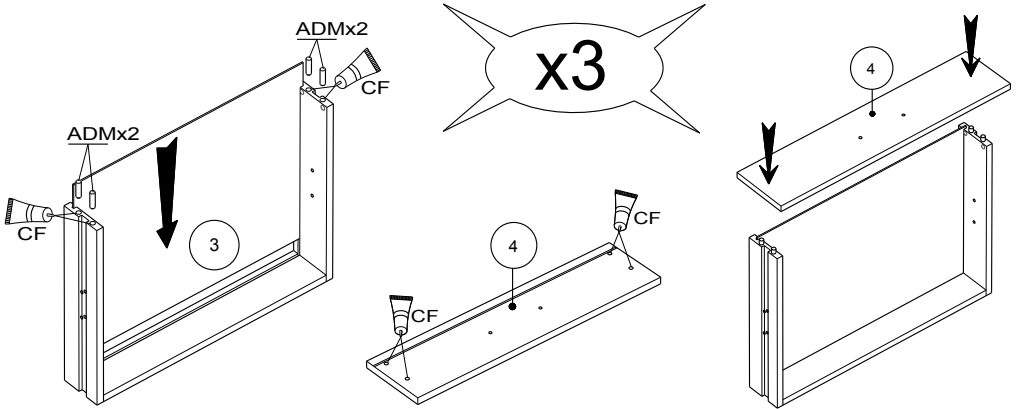
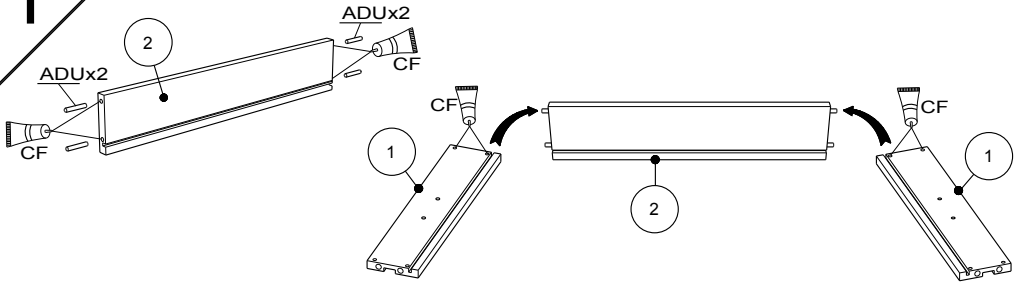

2

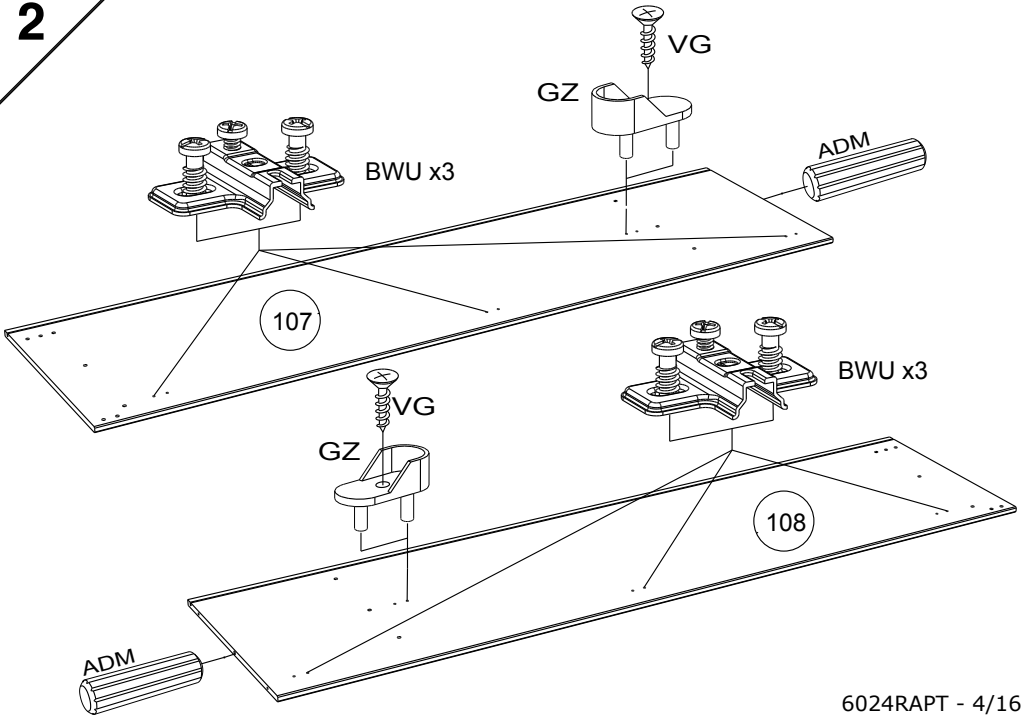

3

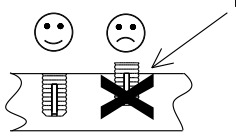
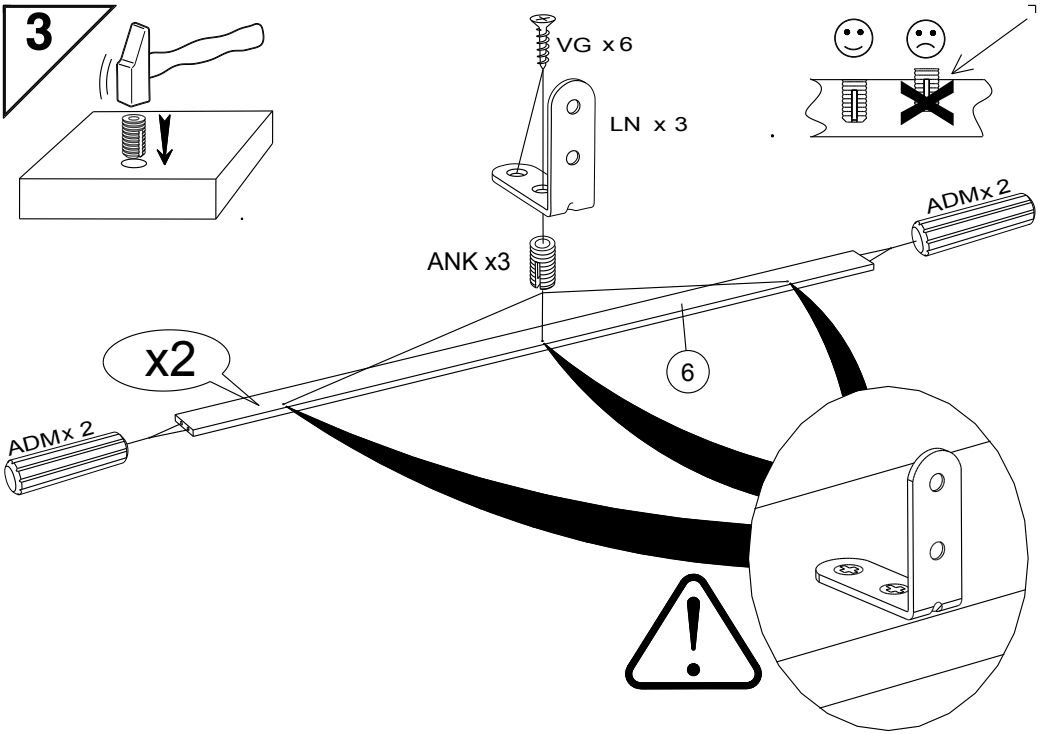
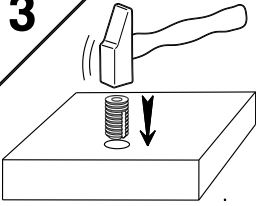

4

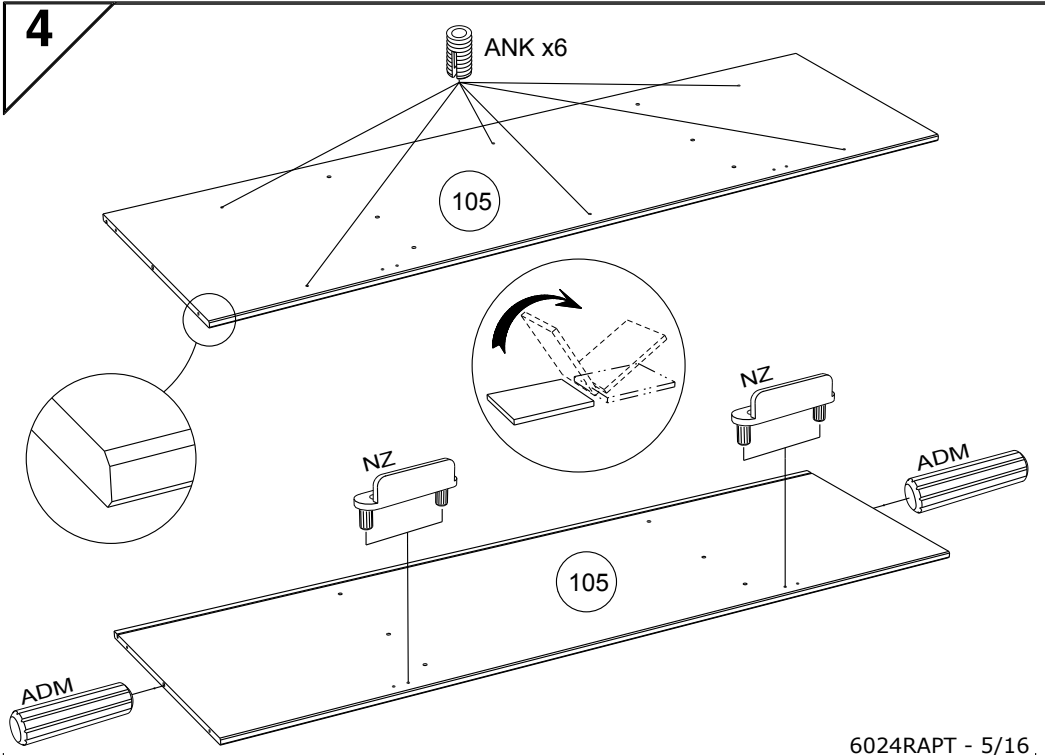

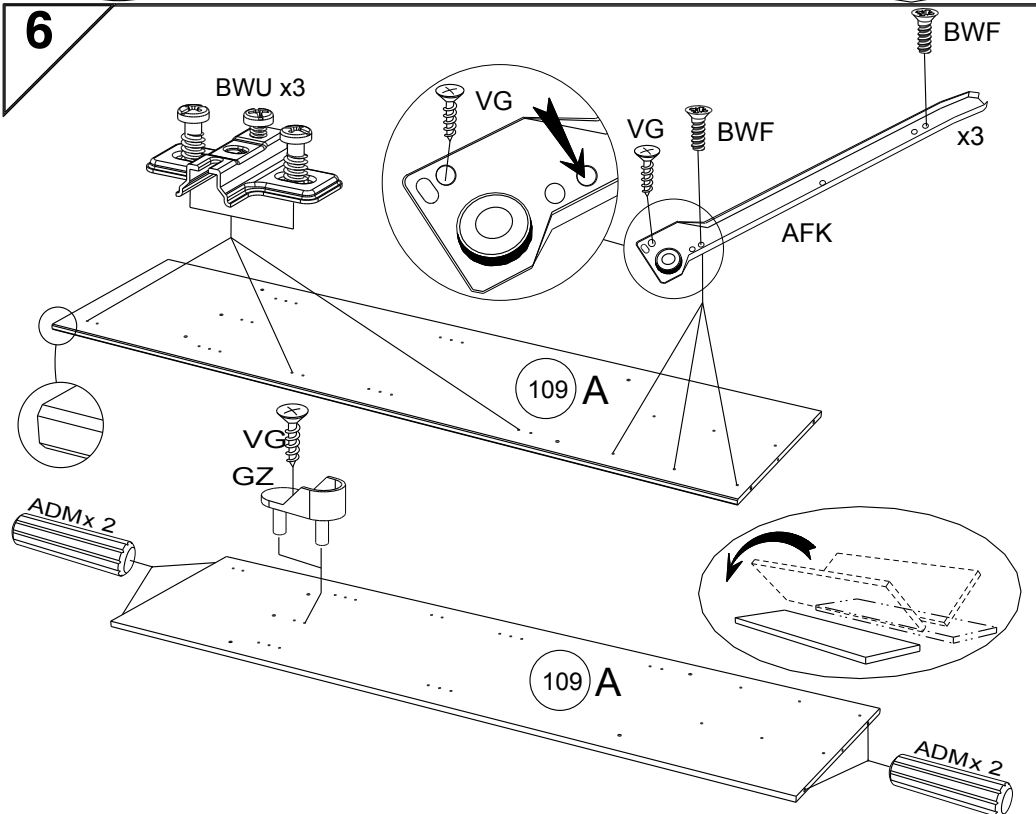
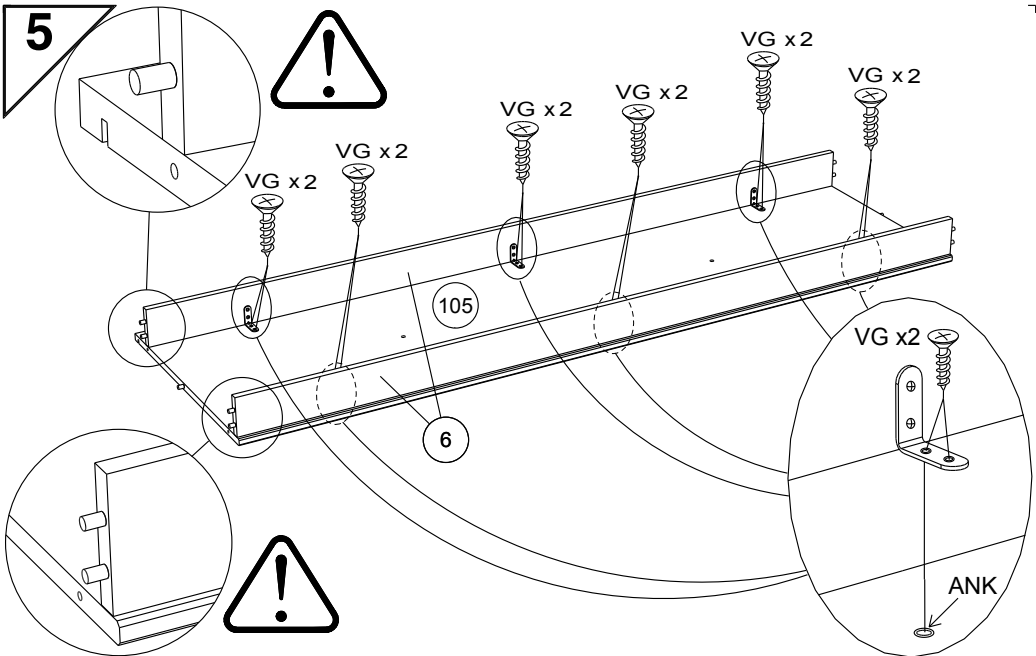

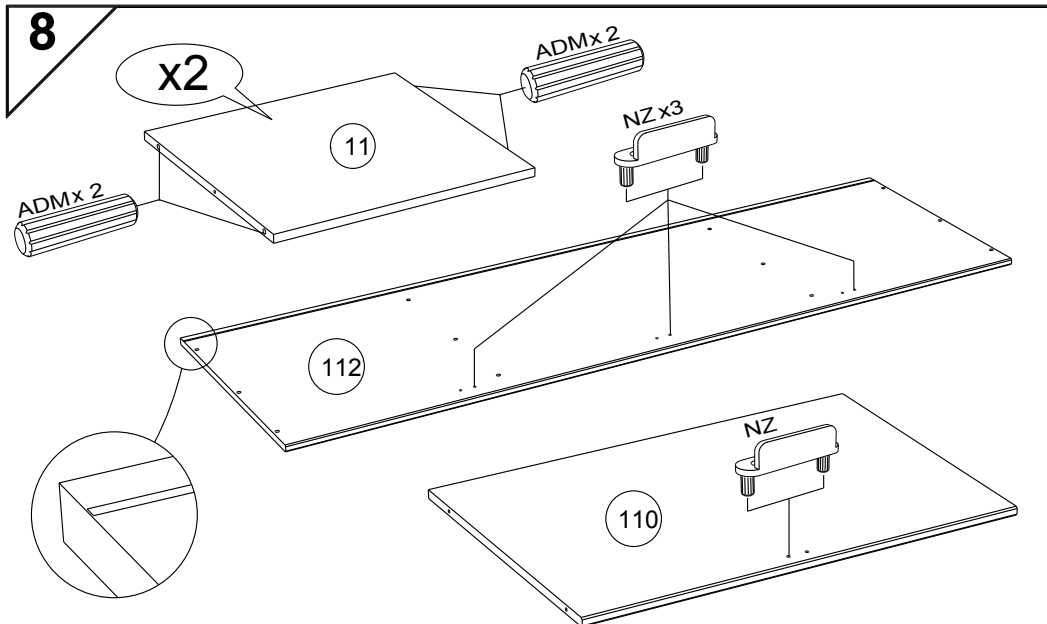
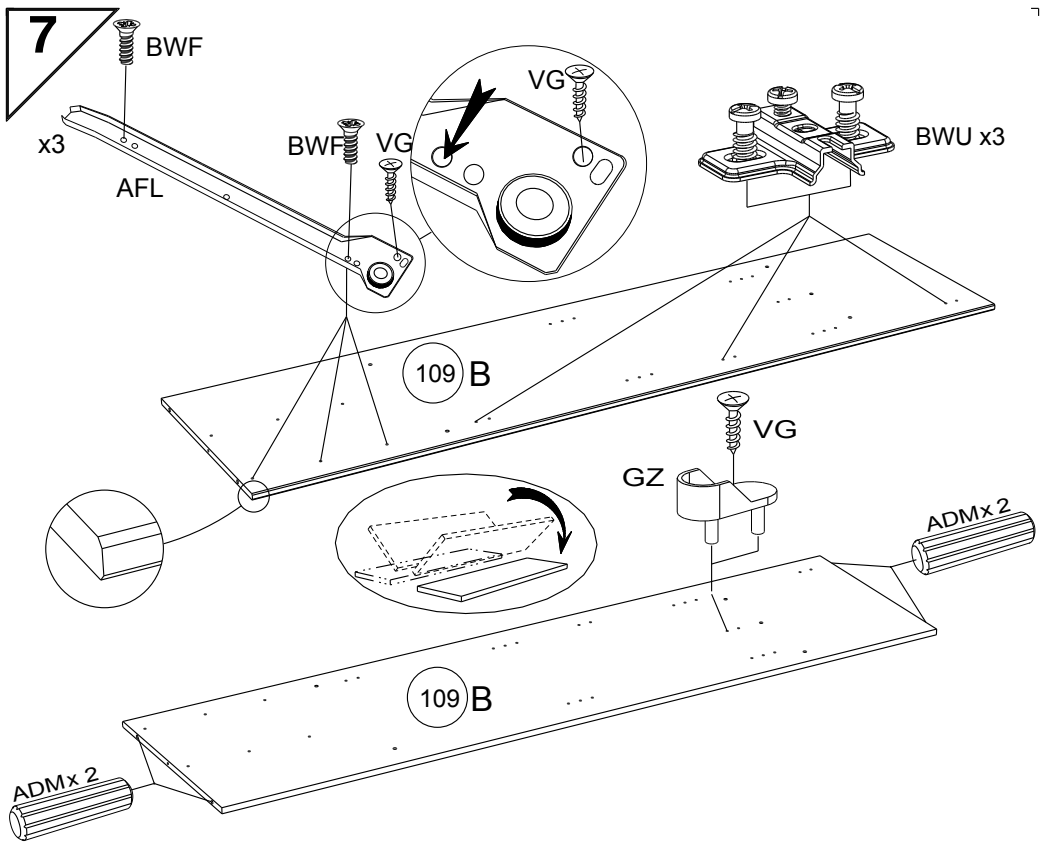

9

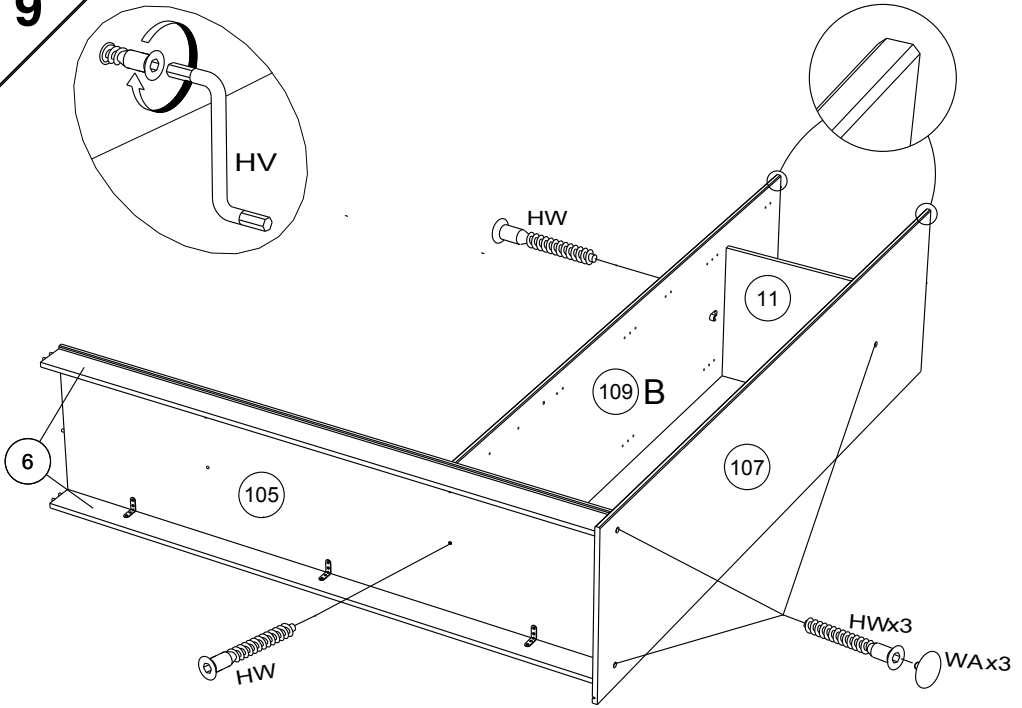

10

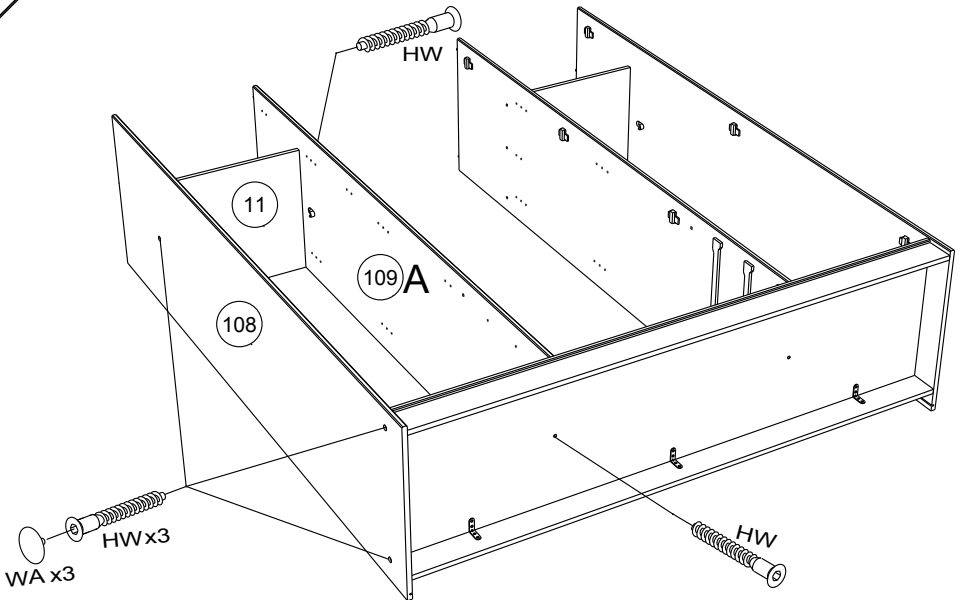

11

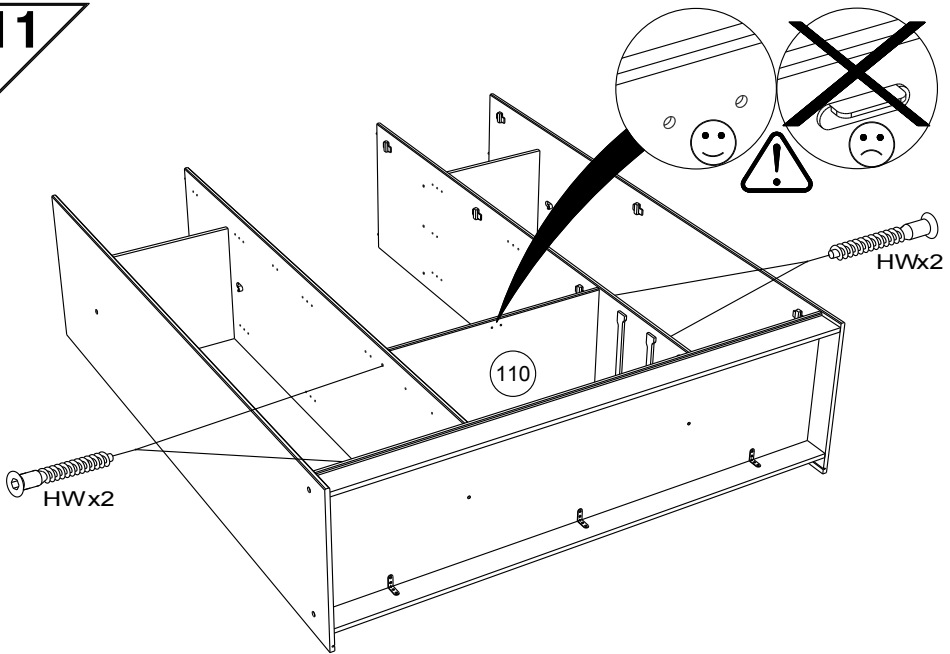

12

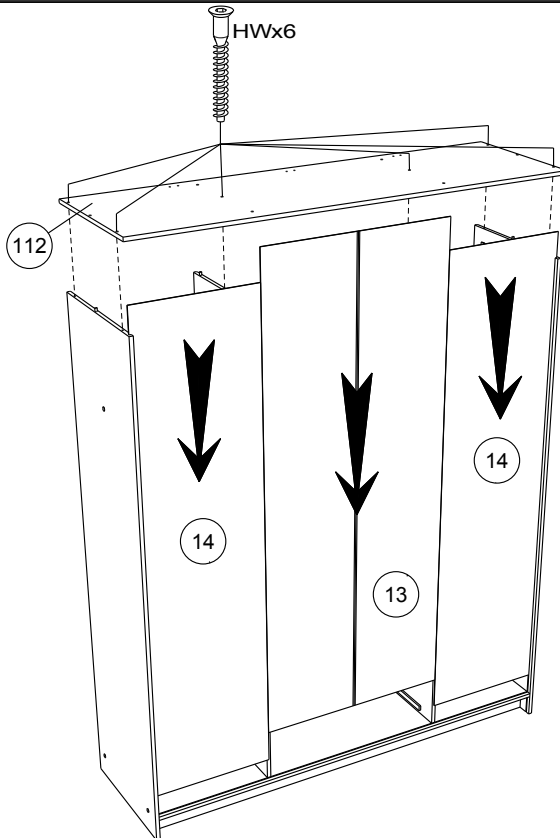

13

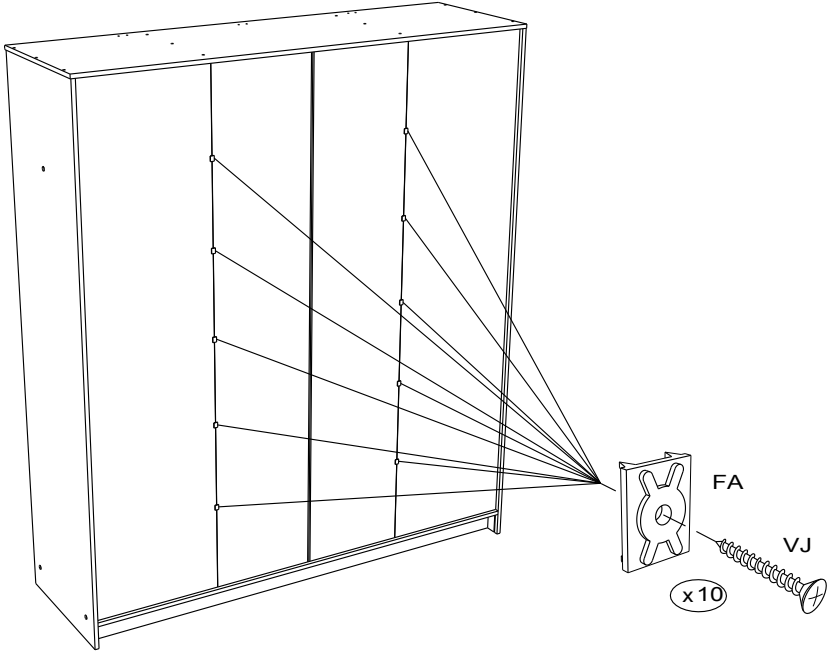

14

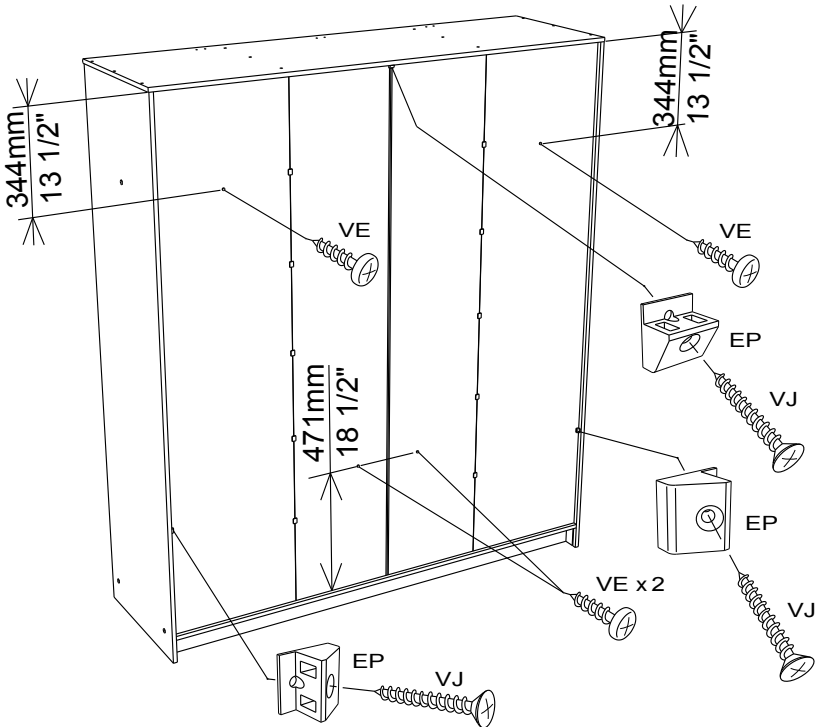

15

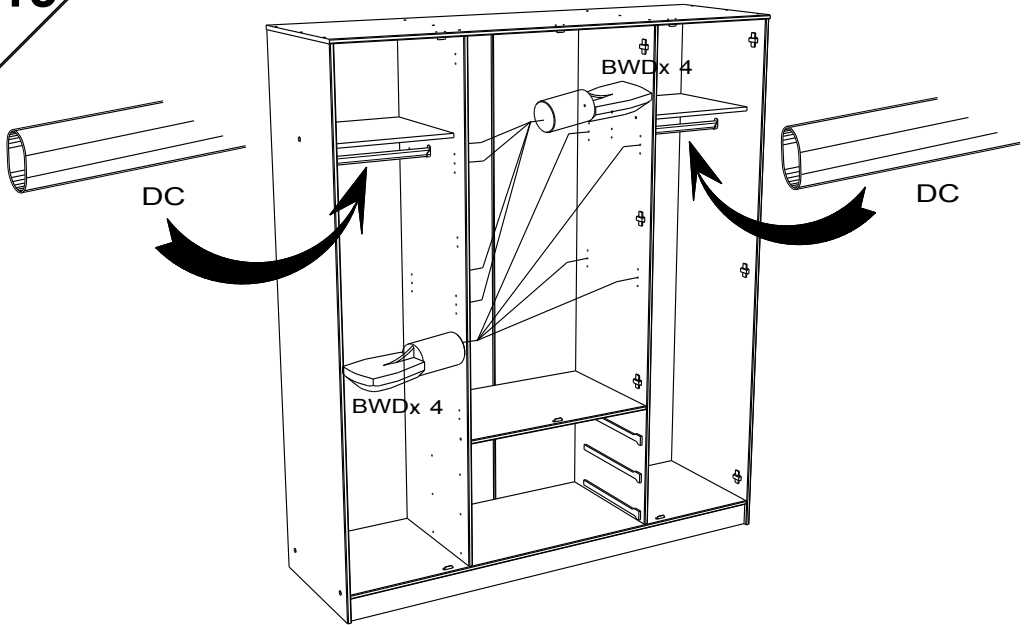

16

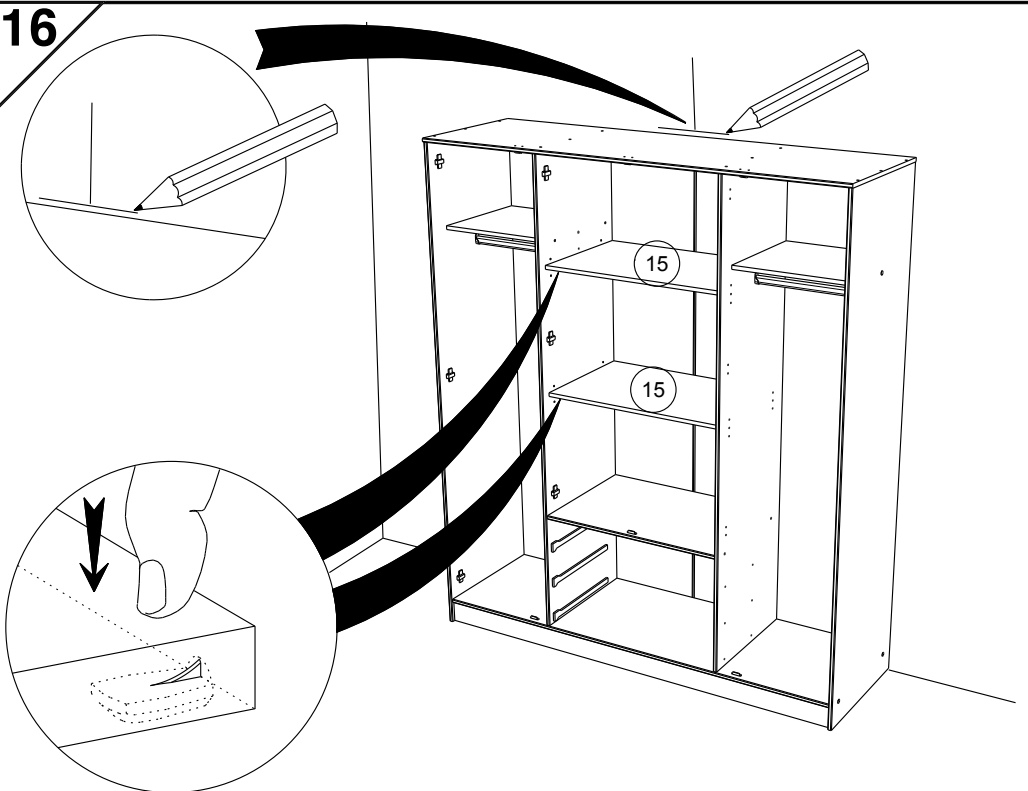

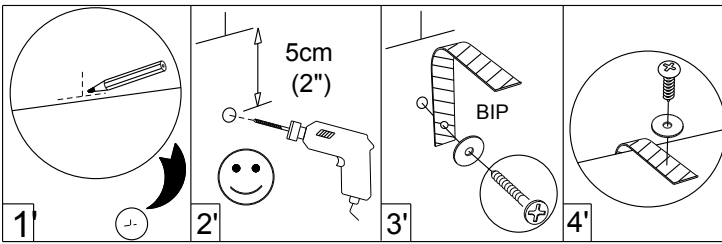

FR Pour votre sécurité : Fixation du meuble au mur
Attention, la fixation doit être réalisée par une personne compétente car cela nécessite des chevilles adaptées à la nature de votre mur.

EN For your safety: the unit should be secured to the wall.
NB this should be carried out by a competent person as you must use the right rawlplug for your type of wall.

DE Zu Ihrer Sicherheit: Befestigen Sie das Hochbett an der Wand.
Achtung: Diese Befestigung ist durch eine fachlich kompetente Person vorzunehmen. Hierfür sind für die Bauweise Ihrer Wand geeignete Dübel einzusetzen.

ES Por su seguridad: Fijar el mueble a la pared.
Advertencia: la fijación la ha de llevar a cabo por personal adecuado, ya que requiere el uso de tacos que se adapten al tipo de pared.

PT Para sua segurança: fixação do móvel ao muro
Atenção: a fixação deverá ser efetuada por pessoa habilitada, visto que são necessárias cavilhas adaptadas ao tipo de parede.

IT Avvertenza di sicurezza: il fissaggio del mobile a parete deve essere realizzato da una persona competente, in quanto l'operazione richiede l'impiego di tasselli adatti alla natura del muro.

NL Voor uw veiligheid: bevestiging van het meubel aan de muur.
Opgelet de bevestiging moet worden uitgevoerd door een bekwaam persoon daar dit voor uw type muur geschikte pluggen vereist.

CZ Z bezpečnostních důvodů: upevněte nábytek do zdi
Pozor, upevnění je třeba svěřit kompetentní osobě, neboť vyžaduje hmoždinky vhodné pro vaši zed.

HU Az Ön biztonsága érdekében : a bútor falra rögzítése
Figyelmeztetés : a rögzítés csak megfelelő szakképesítéssel rendelkező személy által végezhető el, mert a rögzítéshez a falnak megfelelő csavarokra van szükség.

PL Dla bezpieczeństwa: mocowanie mebla do ściany
Uwaga, mocowanie musi zostać wykonane przez osobę kompetentną, ponieważ wymaga to zastosowania kołków dostosowanych do rodzaju ściany.

RO Pentru securitatea dumneavoastră: fixarea mobilierului de perete
Atenție, fixarea trebuie să fie realizată de o persoană calificată, deoarece sunt necesare dispozitive de fixare adaptate caracteristicilor peretelui dumneavoastră

RU Для вашей безопасности: Крепление мебели к стене
Внимание! Крепление должно производиться опытным специалистом, т.к. для такой установки потребуются штифты, соответствующие типу вашей стены.

SK Z bezpečnostných dôvodov: nábytek upevnite k stene.
Dbajte na to, aby upevnenie vykonala kompetentná osoba, pretože pri upevňovaní sa vyžadujú kolíky vhodné do materiálu, z ktorého je stena vyrobená.

TR Güvenliğiniz için: Mobilyanın duvara sabitlenmesi
Dikkat, sabitleme işlemi uzman biri tarafından yapılmalıdır çünkü bu işlem için duvarınızın malzemesine uygun dübellerin kullanılması gerekmektedir

GR Για την ασφάλειά σας : στερέωση των επίπλων στον τοίχο.
Προσοχή, η στερέωση πρέπει να γίνεται από ικανό άτομο, καθώς απαιτούνται σφήνες προσαρμοσμένες στη φύση του τοίχου σας.

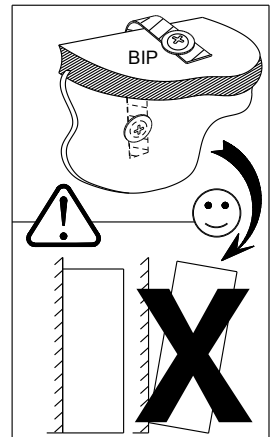
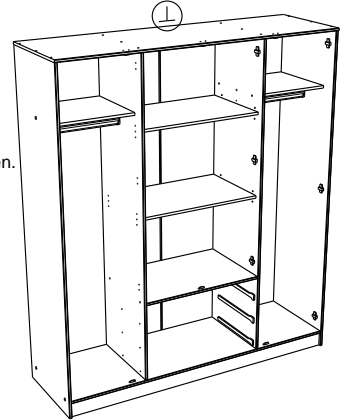

اللغة العربية

لسلامتكم الشخصية: تثبيت قطعة الأثاث على الحائط

تحذير، يجب أن يقوم شخص متخصص بعملية التثبيت على الحائط إذ أنها تتطلب اسفينا معينا يتوافق مع طبيعة الحائط نفسه.

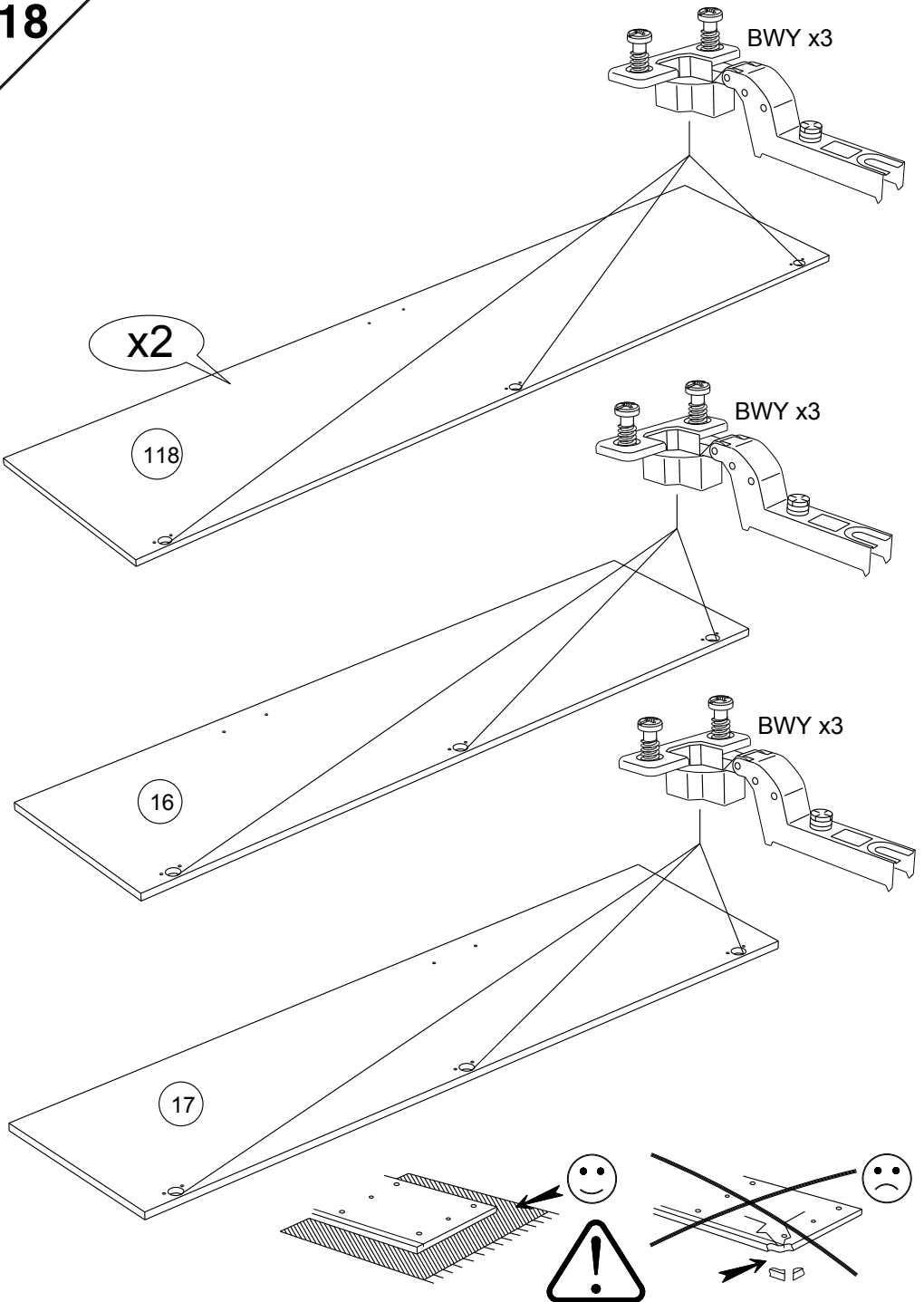

19

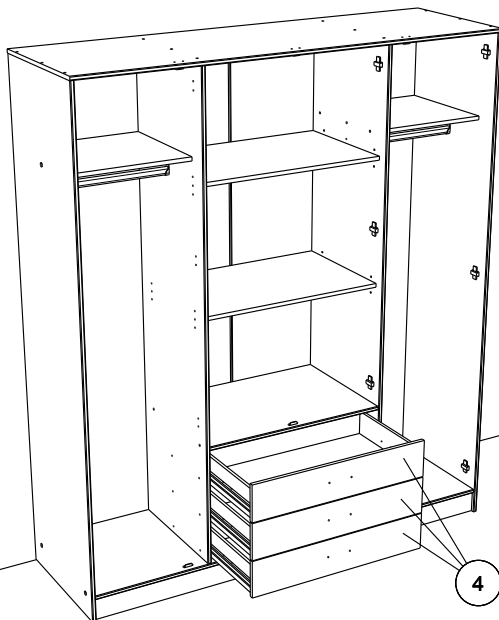
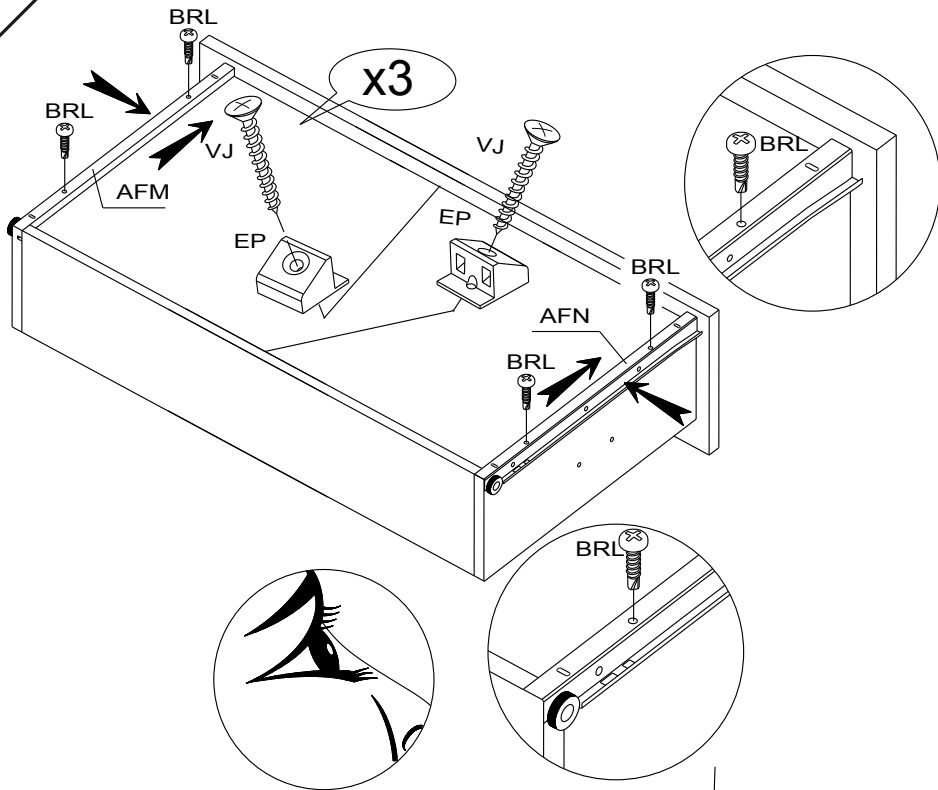

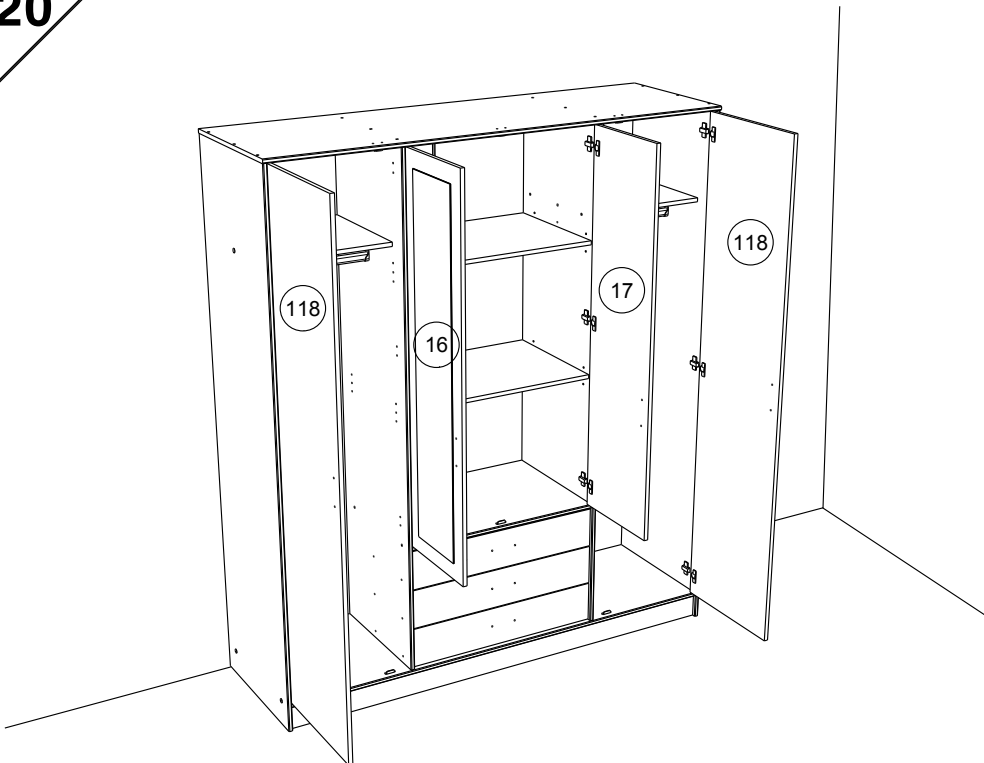

RCH-N

MONTAGE

- (GB) LEAFLET
- (D) AUFBAUANLEITUNG
- (E) MONTAJE
- (P) MONTAGEM
- (I) MONTAGGIO
- (NL) MONTAGE

REGLAGE (GB) ADJUSTING (E) AJUSTER (I) AGGIUSTAMENTO
(D) ANPASSUNG (P) REGULACAO (NL) AFSTELLING

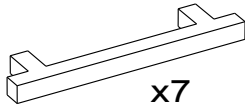
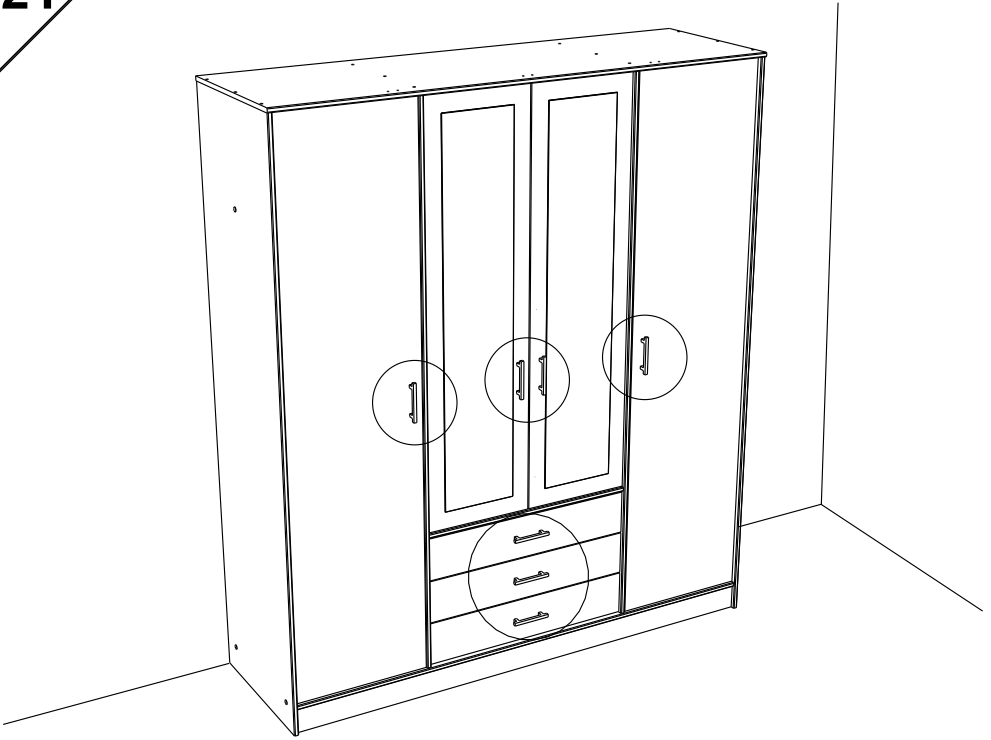

x7

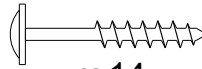

x 14

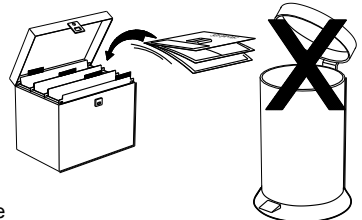

Faites un geste pour l'environnement en triant vos déchets d'emballage
Make a gesture for the environment by sorting out your waste of packaging
Machen Sie eine Bewegung für die Umwelt, ihre Verpackungsabfälle sortierend
Haga un gesto para el medio ambiente escogiendo sus residuos de embalaje