

5903C03T

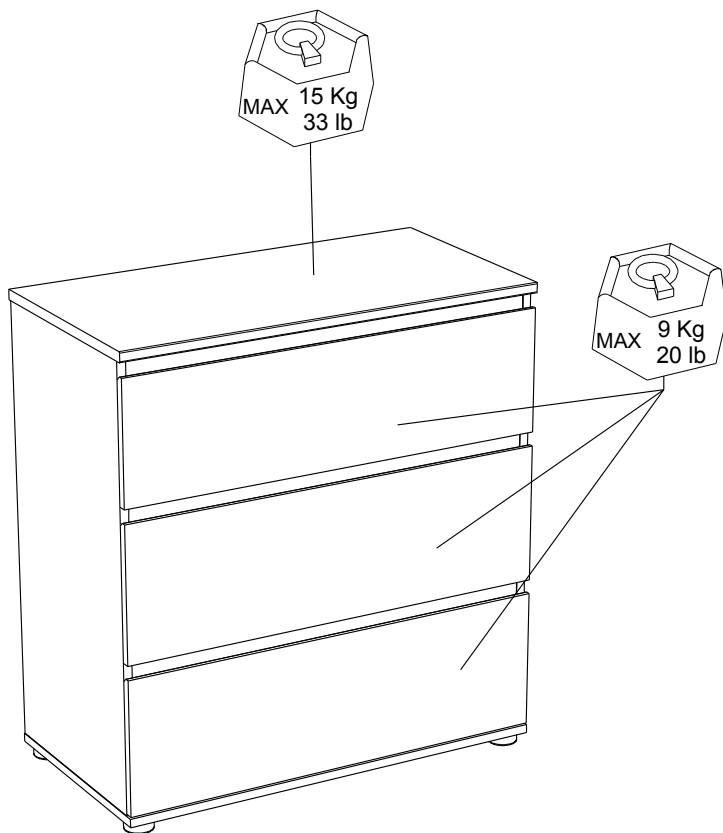

FR Remerciements :

Nous vous remercions d'avoir choisi un meuble créé et fabriqué par le Groupe Parisot et espérons qu'il vous donnera entière satisfaction.

EN Thanks:

Thank you for choosing furniture designed and manufactured by the Parisot Group. We hope you are totally satisfied with your purchase.

DE Danksagung:

Wir danken Ihnen für den Kauf eines Frankreich von der Parisot-Gruppe entworfenen und hergestellten Möbelstücks und hoffen, dass Sie es zu Ihrer vollkommenen Zufriedenheit finden werden.

ES Agradecimientos:

Les damos las gracias por haber elegido un mueble diseñado y fabricado por el Groupe Parisot y esperamos que sea de su total agrado.

PT Agradecimentos:

Obrigado por ter escolhido um móvel concebido e fabricado pelo Grupo Parisot, esperando que seja do seu inteiro agrado.

IT Ringraziamenti:

Grazie per avere scelto un mobile progettato e fabbricato dal Gruppo Parisot. Speriamo soddisfisi appieno le vostre esigenze.

NL Bedankje:

Wij bedanken u voor de aankoop van een door de Groep Parisot ontworpen en vervaardigd meubel en hopen dat u er veel plezier aan zult beleven.

CZ Poděkování:

Děkujeme, že jste si vybrali nábytek navržený a vyrobený společností Parisot Group. Doufáme, že budete svým nákupem naprosto spokojeni.

HU Köszönet:

Köszönjük, hogy a Parisot Groupe által létrehozott és gyártott bútort választott, reméljük, hogy elégedett lesz a termékkel.

PL Podziękowania:

Dziękujemy za wybór mebli stworzonych i wyprodukowanych przez Grupę Parisot. Mamy nadzieję, że będziecie Państwo w pełni zadowoleni z zakupem.

RO Mulțumiri:

Vă mulțumim că ați ales un articol de mobilier conceput și fabricat de Grupul Parisot și sperăm că veți fi pe deplin satisfăcuți de acesta.

RU Благодарность:

Мы благодарим вас за то, что вы выбрали мебель, созданную и произведенную Групп Паризо, и надеемся, что вы будете полностью удовлетворены нашей продукцией.

SK Pod'akovanie:

Ďakujeme, že ste si vybrali nábytok navrhnutý a vyrobený spoločnosťou Parisot Group. Dúfame, že budete svojím nákupom absolútne spokojní.

TR Teşekkür ederiz:

Parisot Group tarafından tasarlanan ve üretilen bu mobilyayı seçtiğiniz için teşekkür ederiz. Ürünümüzden memnun kalmanızı ümit ederiz.

AR : شكر

نشكركم لاختياركم هذه القطعة من الأثاث من تصميم وتصنيع مجموعة باريسو Parisot ونتمنى أن تتلوا رضاهم.

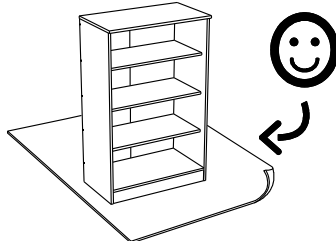
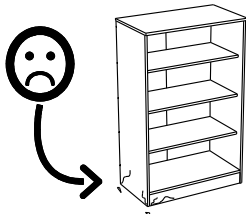
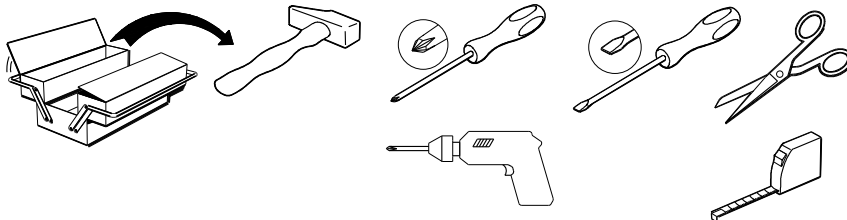

contact@parisot.com

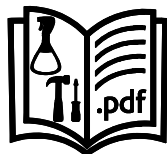

www.parisot.com

82.5cm
32 1/2"
77cm
30 1/4"
40cm
15 3/4"

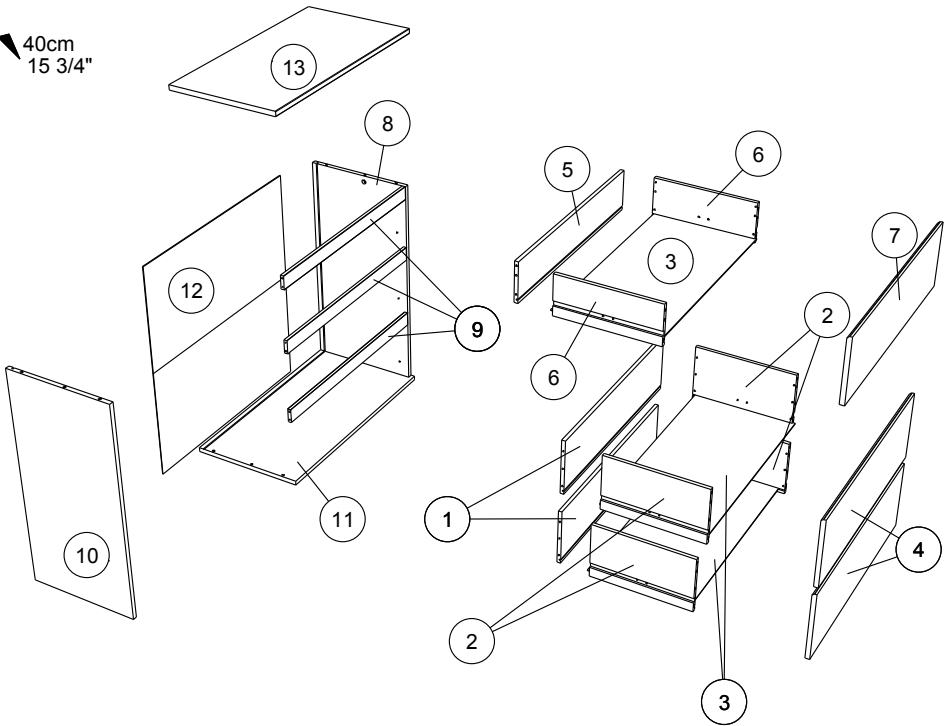

		mm			inch		
9	x 3	732	50	12	28 13/16	1 15/16	1/2
7	x 1	762	215	15	30	8 7/16	9/16
4	x 2	762	239	15	30	9 7/16	9/16
11	x 1	764	399	15	30 1/16	15 11/16	9/16
13	x 1	767	399	18	30 3/16	15 11/16	11/16
8	x 1	771	384	15	30 3/8	15 1/8	9/16
10	x 1	771	384	15	30 3/8	15 1/8	9/16
6	x 2	350	139	13	13 3/4	5 1/2	1/2
2	x 4	350	196	13	13 3/4	7 11/16	1/2
1	x 2	699	196	13	27 1/2	7 11/16	1/2
5	x 1	699	139	13	27 1/2	5 1/2	1/2
3	x 3	710	349	3	27 15/16	13 3/4	1/8
12	x 1	787	748	3	31	29 7/16	1/8



Ai x 2

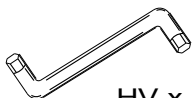

HV x 1

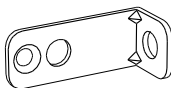

BLL x 1



EP x 8

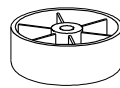

BXC x 4

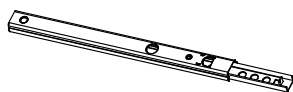

Ci x 6



CF x 2

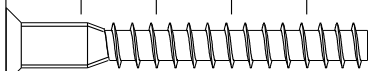
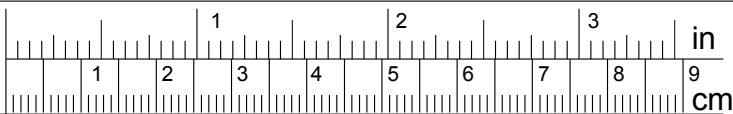

HW x 2



ADU x 30

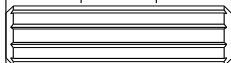

ADM x 30

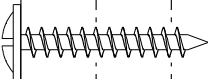

XN x 4

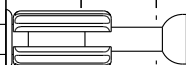

BSD x 2

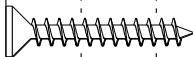

VJ x 8

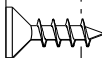

VG x 13



VR x 6



ANK x 12

1

ADU x12

ADM x16

CF x1

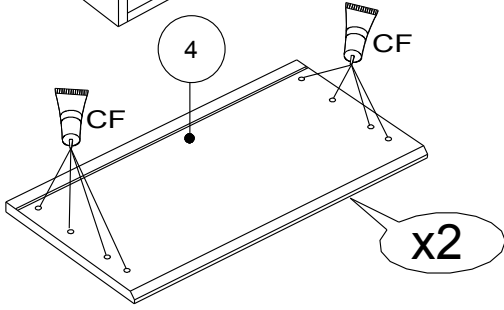
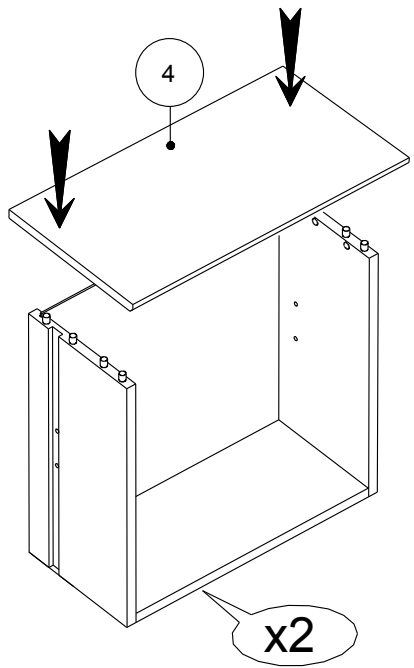
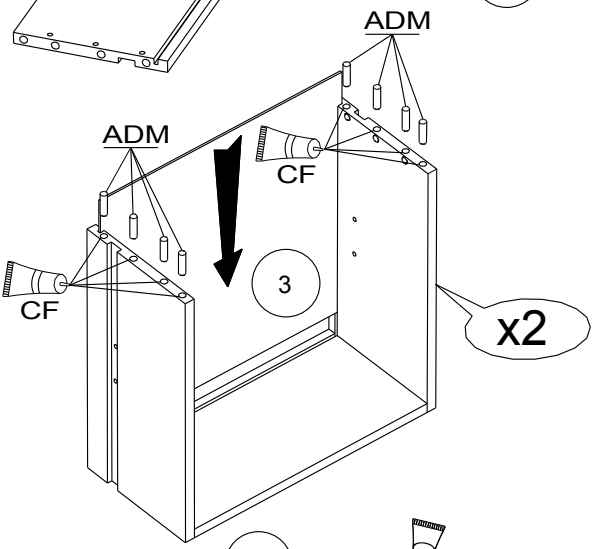
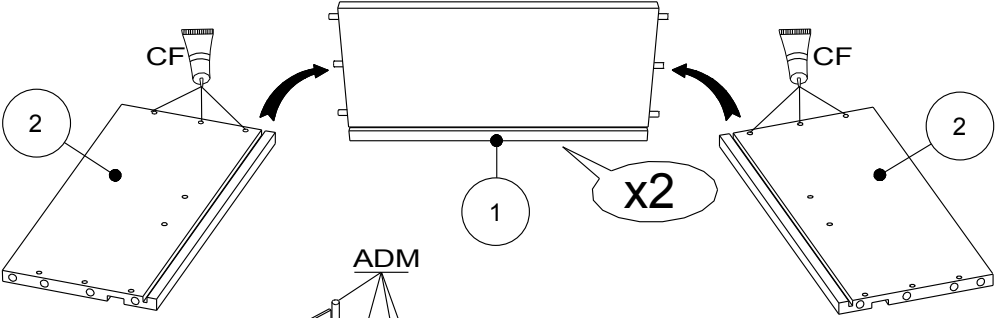
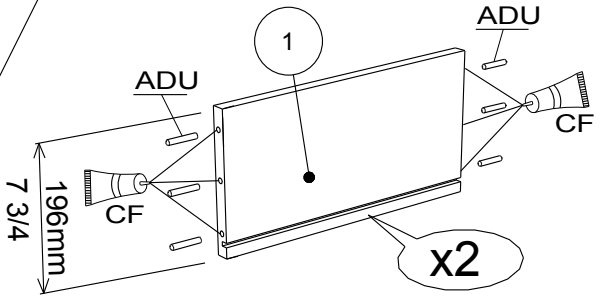

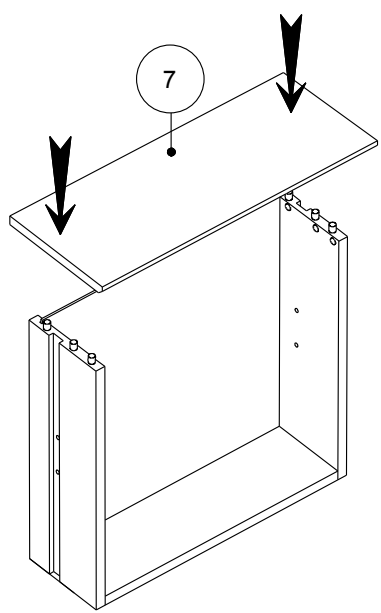
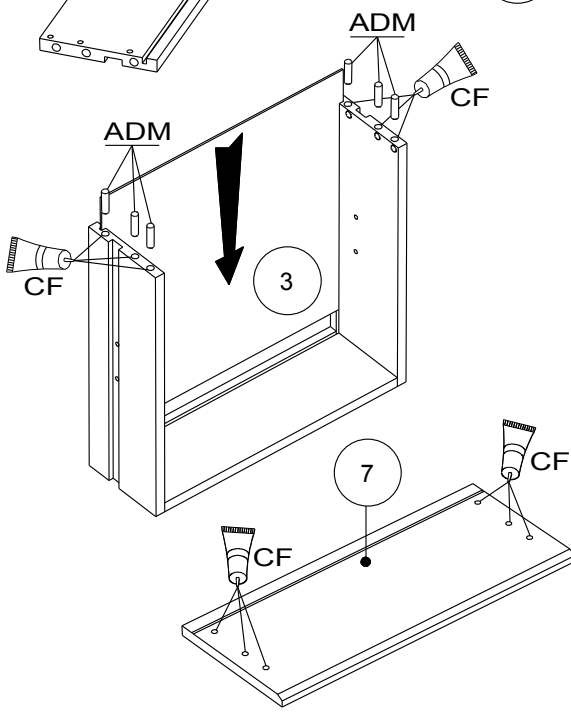
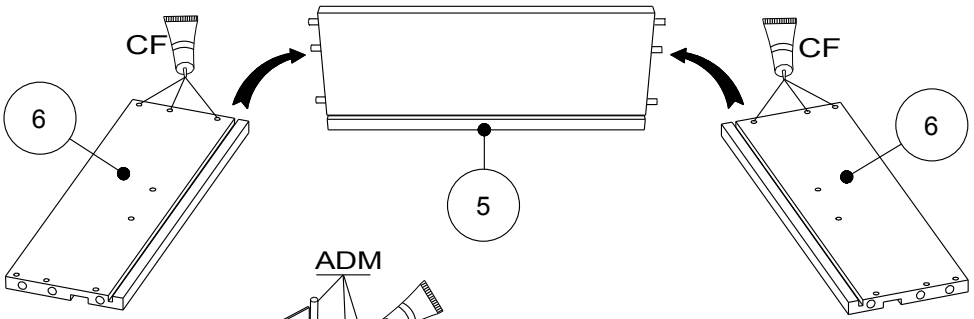
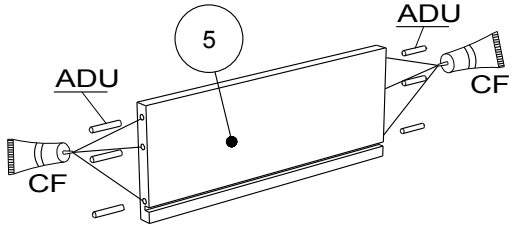
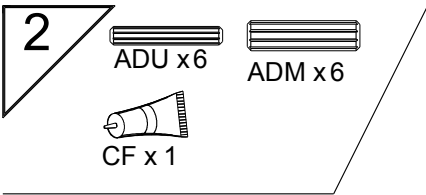

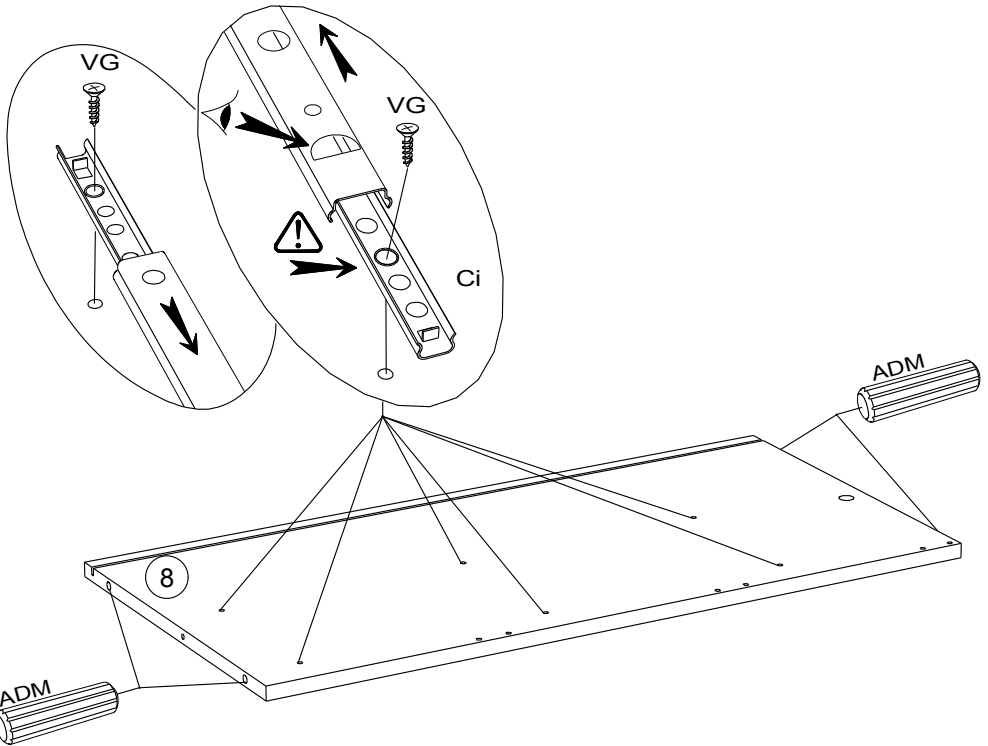
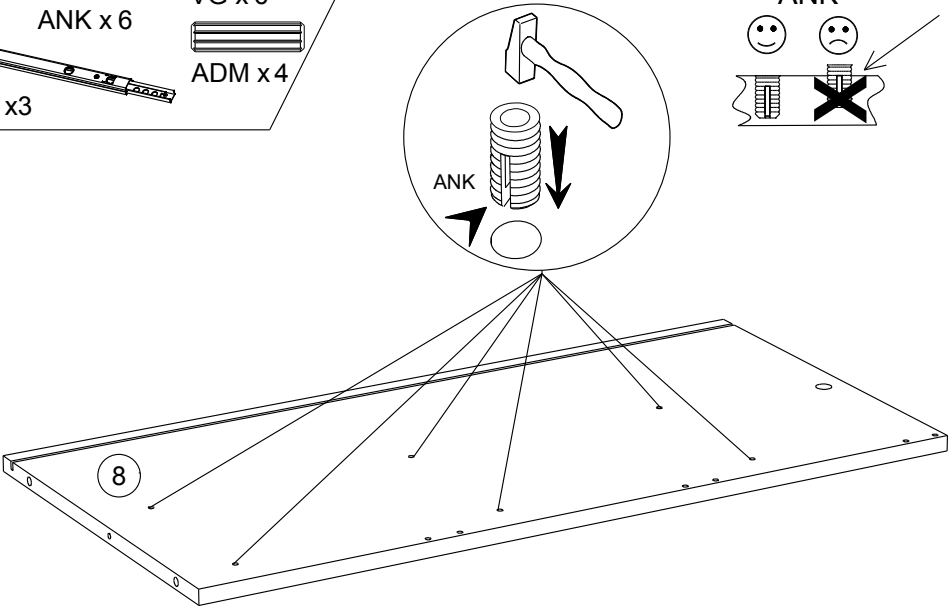
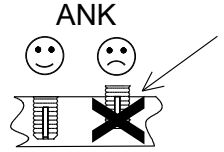
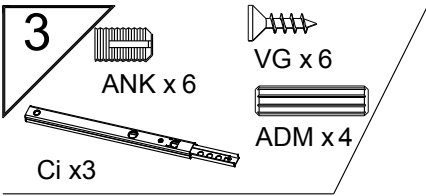

4

ANK x 6

VG x 6

ADM x 4

Ci x 3

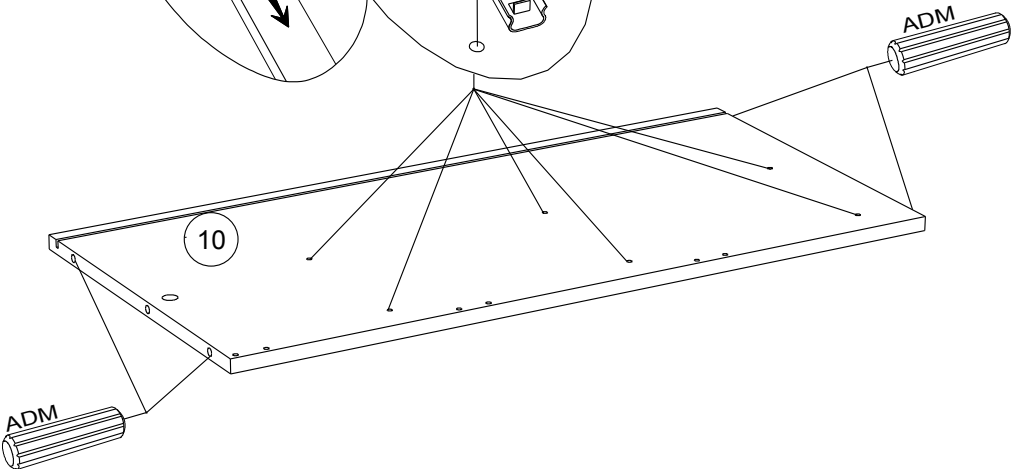
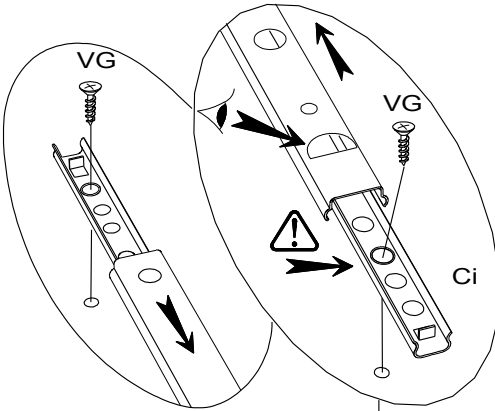
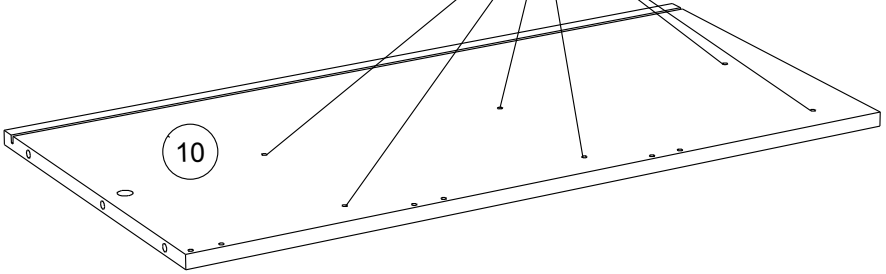
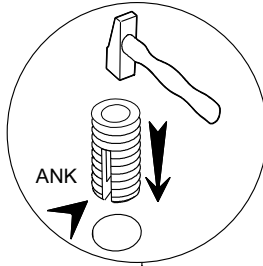

5

ADU x12

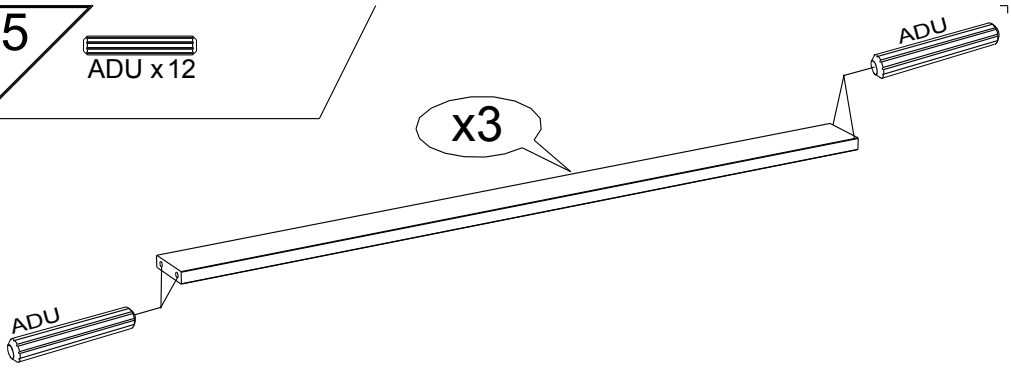

6

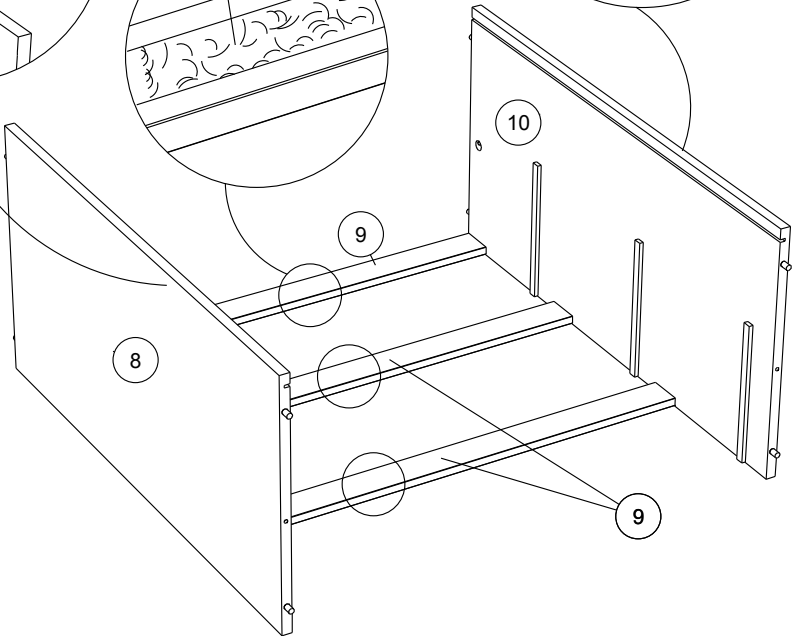
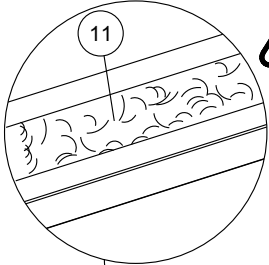
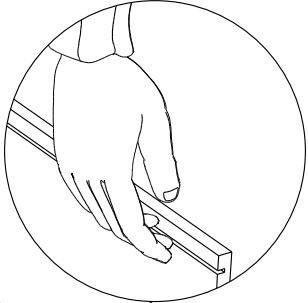
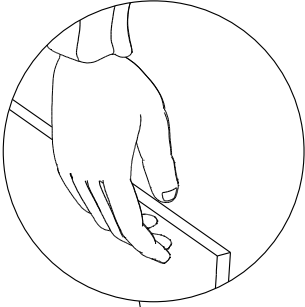

7

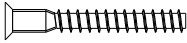

HW x 2

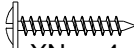

XN x 4



BXC x 4

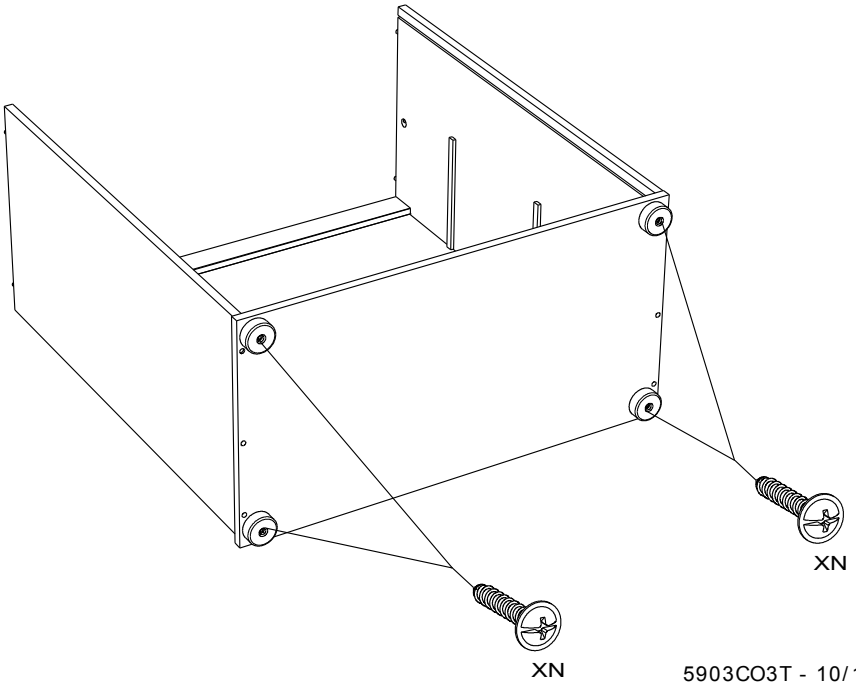
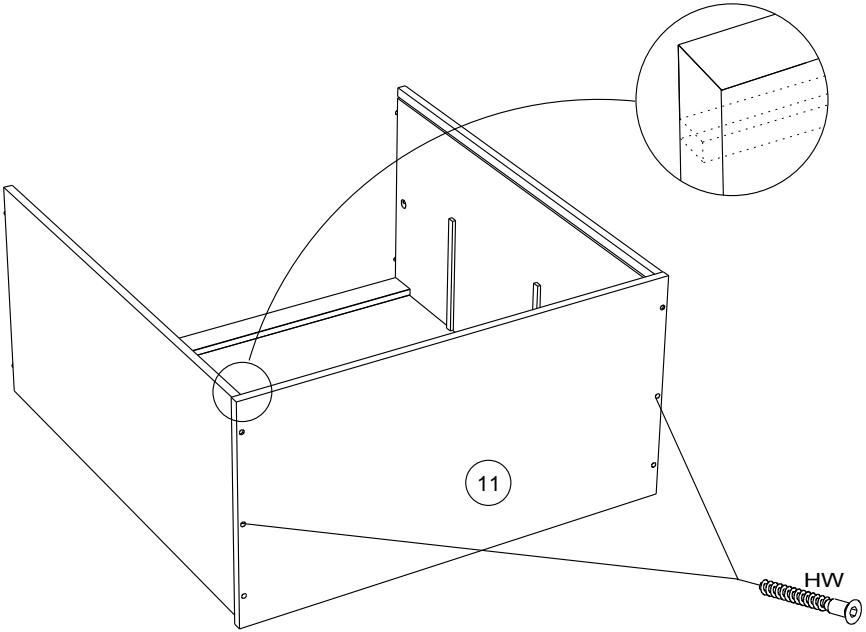

8

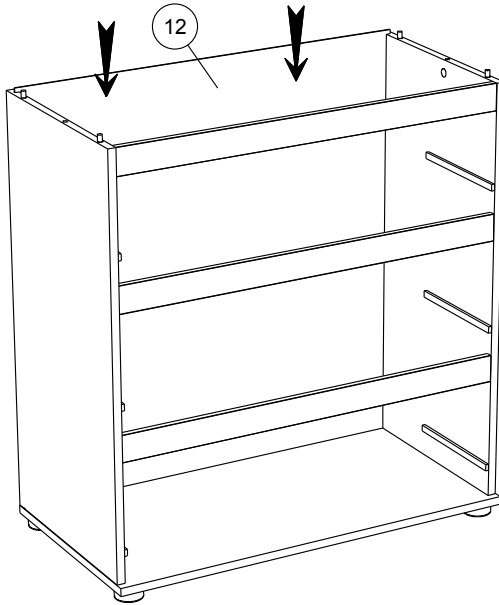

9

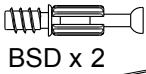

VG x 1

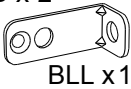

BLL x 1

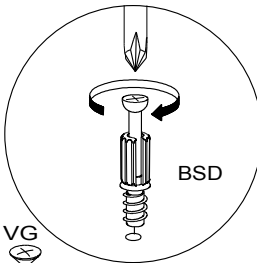

BSD

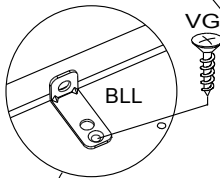
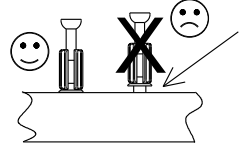

VG

BLL

BSD

BSD

13

10



Ai x2

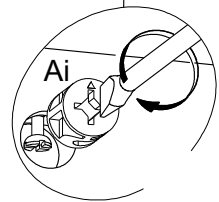
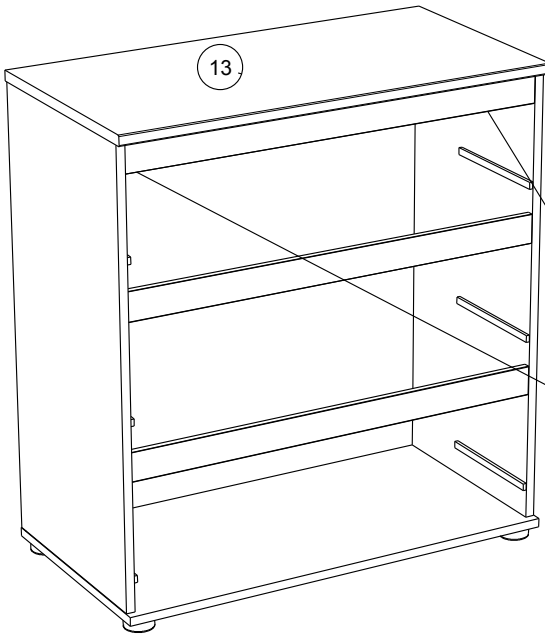

11



EP x 2

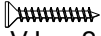

VJ x 2

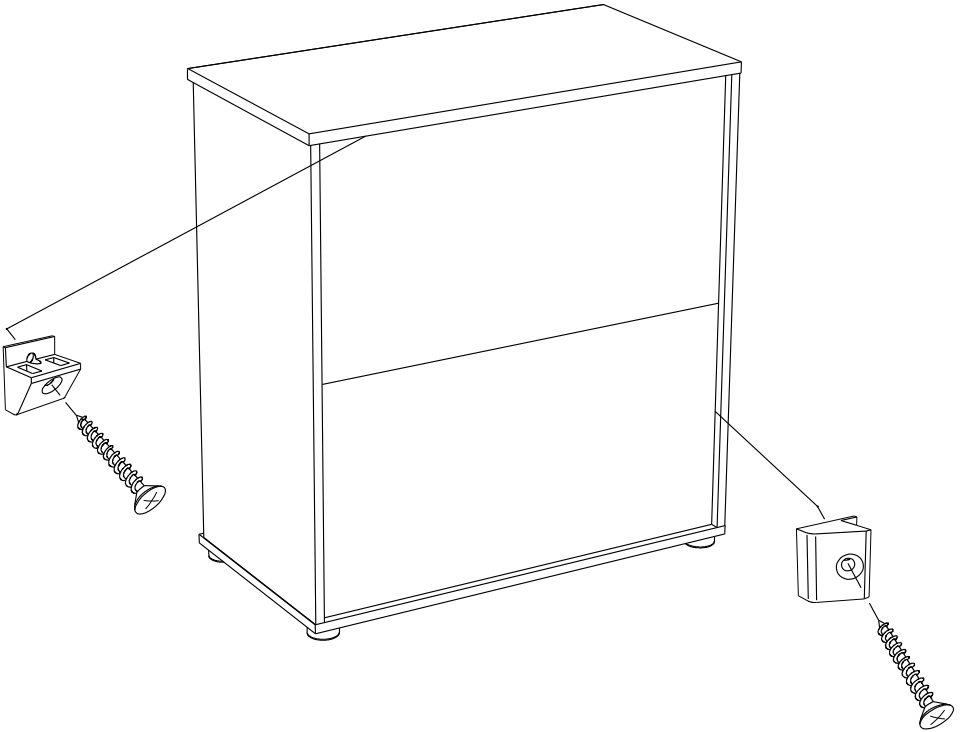

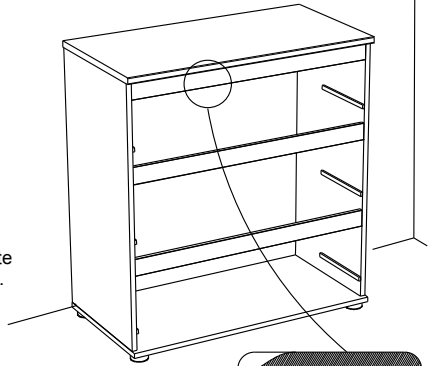

FR Pour votre sécurité : Fixation du meuble au mur

Attention, la fixation doit être réalisée par une personne compétente car cela nécessite des chevilles adaptées à la nature de votre mur.

EN For your safety: the unit should be secured to the wall.

NB this should be carried out by a competent person as you must use the right rawlplug for your type of wall.

DE Zu Ihrer Sicherheit: Befestigen Sie das Hochbett an der Wand.

Achtung: Diese Befestigung ist durch eine fachlich kompetente Person vorzunehmen. Hierfür sind für die Bauweise Ihrer Wand geeignete Dübel einzusetzen.

ES Por su seguridad: Fijar el mueble a la pared.

Advertencia: la fijación la ha de llevar a cabo por personal adecuado, ya que requiere el uso de tacos que se adapten al tipo de pared.

PT Para sua segurança: fixação do móvel ao muro

Atenção: a fixação deverá ser efetuada por pessoa habilitada, visto que são necessárias cavilhas adaptadas ao tipo de parede.

IT Avvertenza di sicurezza: il fissaggio del mobile a parete deve essere

realizzato da una persona competente, in quanto l'operazione richiede l'impiego di tasselli adatti alla natura del muro.

NL Voor uw veiligheid: bevestiging van het meubel aan de muur.

Opgelet de bevestiging moet worden uitgevoerd door een bekwam persoon daar dit voor uw type muur geschikte pluggen vereist.

CZ Z bezpečnostních důvodů: upevněte nábytek do zdi

Pozor, upevnění je třeba svěřit kompetentní osobě, neboť vyžaduje hmoždinky vhodné pro vaši zeď.

HU Az Ön biztonsága érdekében : a bútor falra rögzítése

Figyelmeztetés : a rögzítés csak megfelelő szakképesítéssel rendelkező személy által végezhető el, mert a rögzítéshez a falnak megfelelő csavarokra van szükség.

PL Dla bezpieczeństwa: mocowanie mebla do ściany

Uwaga, mocowanie musi zostać wykonane przez osobę kompetentną, ponieważ wymaga to zastosowania kółków dostosowanych do rodzaju ściany.

RO Pentru securitatea dumneavoastră: fixarea mobilierului de perete

Atenție, fixarea trebuie să fie realizată de o persoană calificată, deoarece sunt necesare dispozitive de fixare adaptate caracteristicilor peretelui dumneavoastră

RU Для вашей безопасности: Крепление мебели к стене

Внимание! Крепление должно производиться опытным специалистом, т.к. для такой установки потребуются штифты, соответствующие типу вашей стены.

SK Z bezpečnostných dôvodov: nábytok upevnite k stene.

Dbajte na to, aby upevnenie vykonala kompetentná osoba, pretože pri upevňovaní sa vyžadujú kolíky vhodné do materiálu, z ktorého je stena vyrobená.

TR Güvenliğiniz için: Mobilyanın duvara sabitlenmesi

Dikkat, sabitleme işlemi uzman biri tarafından yapılmalıdır çünkü bu işlem için duvarınızın malzemesine uygun dübellerin kullanılması gerekmektedir

GR Για την ασφάλειά σας : στερέωση των επίπλων στον τοίχο.

Προσοχή, η στερέωση πρέπει να γίνεται από ικανό άτομο, καθώς απαιτούνται σήνες προσαρμοσμένες στη φύση του τοίχου σας.

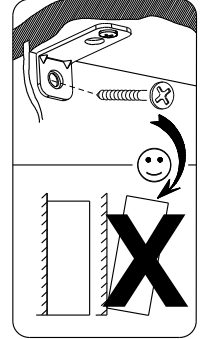

اللغة العربية

لسلامتك الشخصية: تثبيت قطعة الأثاث على الحائط

تحذير، يجب أن يقوم شخص متخصص بعملية التثبيت على الحائط إذ أنها تتطلب اسفينا معيناً يتوافق مع طبيعة الحائط نفسه.

13



EP x4



VJ x 4



VR x 4

x2

4



4

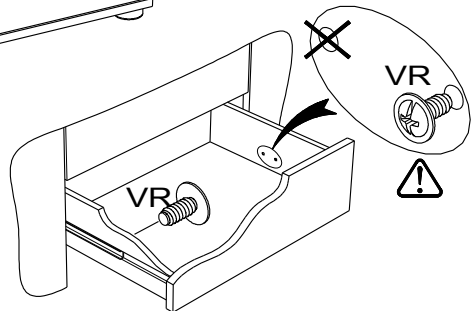

14

