

2303A3PT

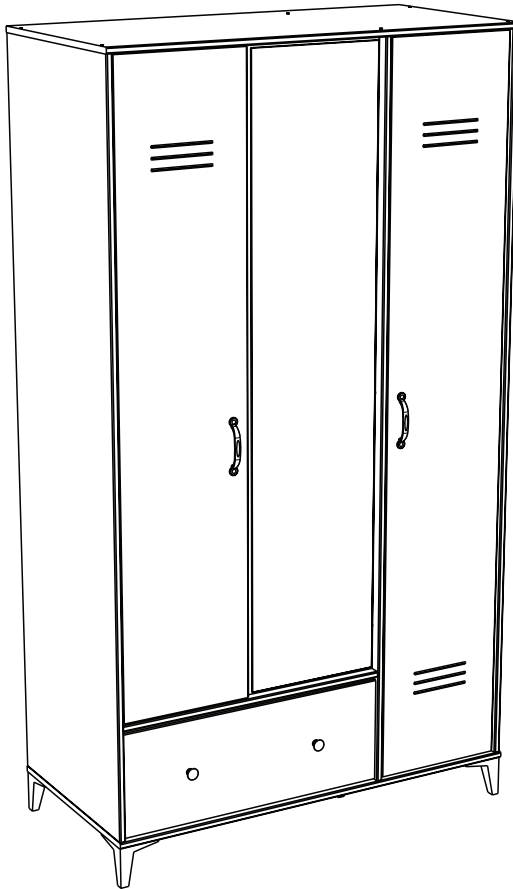

FR Remerciements :

Nous vous remercions d'avoir choisi un meuble créé et fabriqué par le Groupe Pariset et espérons qu'il vous donnera entière satisfaction.

EN Thanks:

Thank you for choosing furniture designed and manufactured by the Pariset Group. We hope you are totally satisfied with your purchase.

DE Danksagung:

Wir danken Ihnen für den Kauf eines Frankreich von der Pariset-Gruppe entworfenen und hergestellten Möbelstücks und hoffen, dass Sie es zu Ihrer vollkommenen Zufriedenheit finden werden.

ES Agradecimientos:

Les damos las gracias por haber elegido un mueble diseñado y fabricado por el Groupe Pariset y esperamos que sea de su total agrado.

PT Agradecimentos:

Obrigado por ter escolhido um móvel concebido e fabricado pelo Grupo Pariset, esperando que seja do seu inteiro agrado.

IT Ringraziamenti:

Grazie per avere scelto un mobile progettato e fabbricato dal Gruppo Pariset. Speriamo soddisfatti appieno le vostre esigenze.

NL Bedankje:

Wij bedanken u voor de aankoop van een door de Groep Pariset ontworpen en vervaardigd meubel en hopen dat u er veel plezier aan zult beleven.

CZ Poděkování:

Děkujeme, že jste si vybrali nábytek navržený a vyrobený společností Pariset Group. Doufáme, že budete svým nákupem naprosto spokojeni.

HU Köszönet:

Köszönjük, hogy a Pariset Groupe által létrehozott és gyártott bútort választott, reméljük, hogy elégedett lesz a termékkel.

PL Podziękowania:

Dziękujemy za wybór mebli stworzonych i wyprodukowanych przez Grupę Pariset. Mamy nadzieję, że będziecie Państwo w pełni zadowoleni z zakupu.

RO Mulțumiri:

Vă mulțumim că ați ales un articol de mobilier conceput și fabricat de Grupul Pariset și sperăm că veți fi pe deplin satisfăcuți de acesta.

RU Благодарность:

Мы благодарим вас за то, что вы выбрали мебель, созданную и произведенную Групп Паризо, и надеемся, что вы будете полностью удовлетворены нашей продукцией.

SK Poďakovanie:

Ďakujeme, že ste si vybrali nábytok navrhnutý a vyrobený spoločnosťou Pariset Group. Dúfame, že budete svojim nákupom absolútne spokojní.

TR Teşekkür ederiz:

Pariset Group tarafından tasarlanan ve üretilen bu mobilyayı seçtiğiniz için teşekkür ederiz. Ürünümüzden memnun kalmanızı ümit ederiz.

AR : شكر

نشكركم لاختياركم هذه القطعة من الأثاث من تصميم وتصنيع مجموعة باريزو Pariset ونتمنى أن تنال رضاكم.

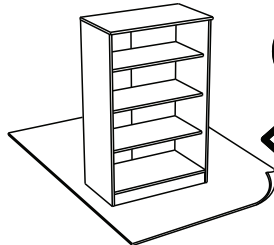
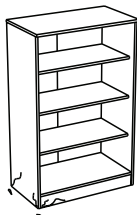
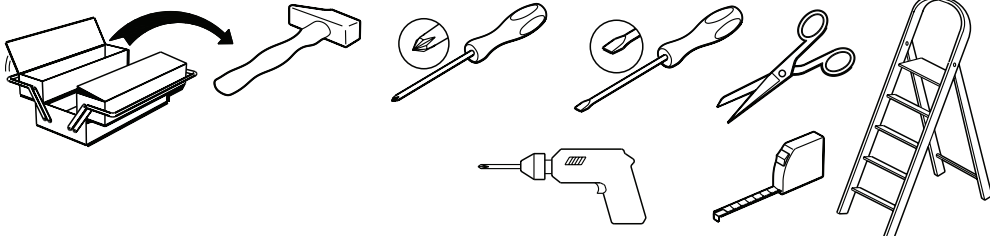

contact@pariset.com



www.pariset.com

194cm
76 1/2"
107.5cm
42 1/4"
52cm
20 1/2"

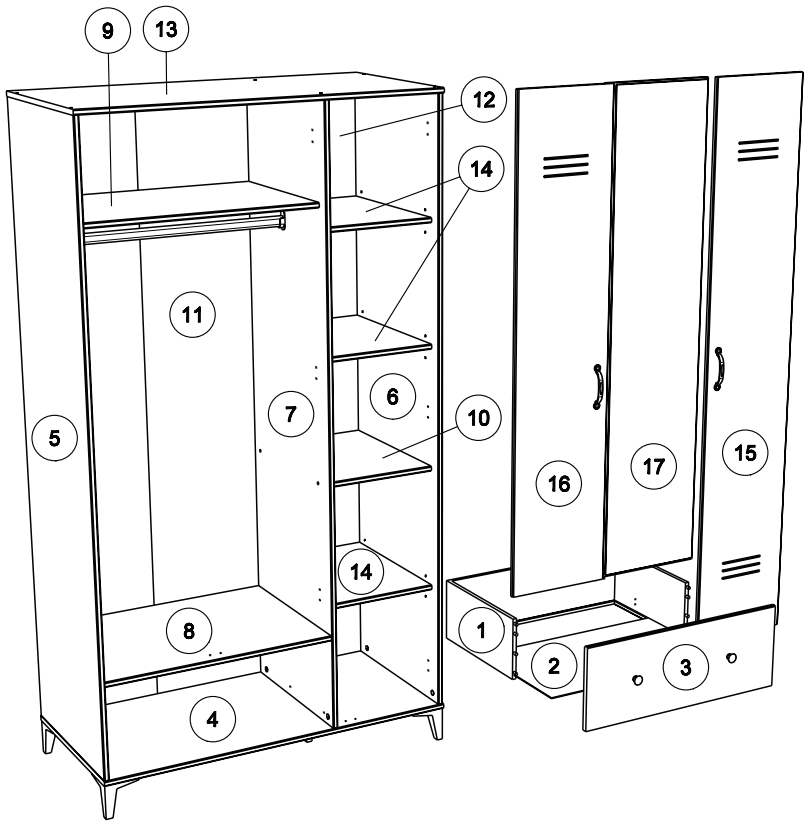

		mm			inch		
⑩	x 1	454	336	15	17 7/8	13 1/4	9/16
⑭	x 3	456	336	15	17 15/16	13 1/4	9/16
③	x 1	683	259	15	26 7/8	10 3/16	9/16
⑨	x 1	687	454	15	27 1/16	17 7/8	9/16
⑧	x 1	687	490	15	27 1/16	19 5/16	9/16
⑬	x 1	1071	518	15	42 3/16	20 3/8	9/16
④	x 1	1071	518	15	42 3/16	20 3/8	9/16
⑯	x 1	1519	330	15	59 13/16	13	9/16
⑰	x 1	1519	370	19	59 13/16	14 9/16	3/4
⑮	x 1	1803	330	15	71	13	9/16
⑦	x 1	1809	494	15	71 1/4	19 7/16	9/16
⑥	x 1	1809	514	15	71 1/4	20 1/4	9/16
⑤	x 1	1809	514	15	71 1/4	20 1/4	9/16
②	x 1	646	399	3	25 7/16	15 11/16	1/8
①	x 1	661	400	196	26	15 3/4	7 11/16
⑫	x 1	1825	351	3	71 7/8	13 13/16	1/8
⑪	x 1	1825	702	3	71 7/8	27 5/8	1/8

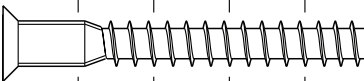
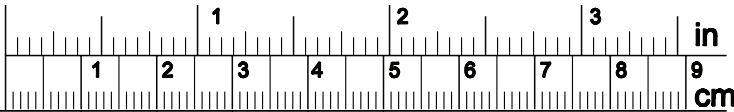
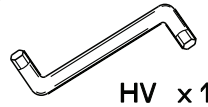
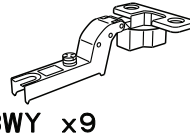
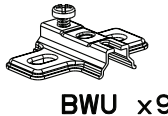
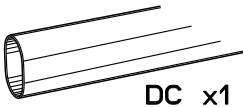
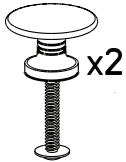
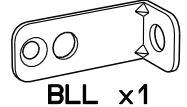
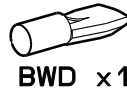
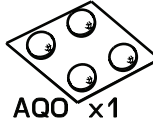
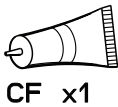
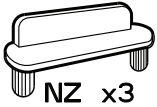
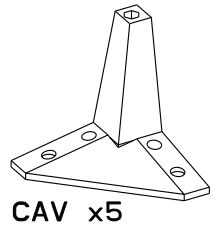
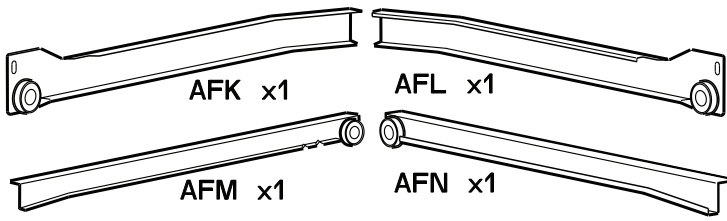

HW x12



ADM x17

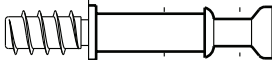
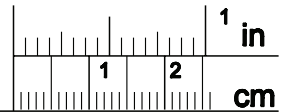

BWC x12



BWF x4

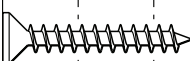

VJ x9

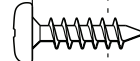

VE x25

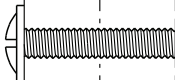

XM x4



ANK x5

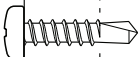

BRL x4

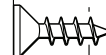

VG x3

1

CF x 1

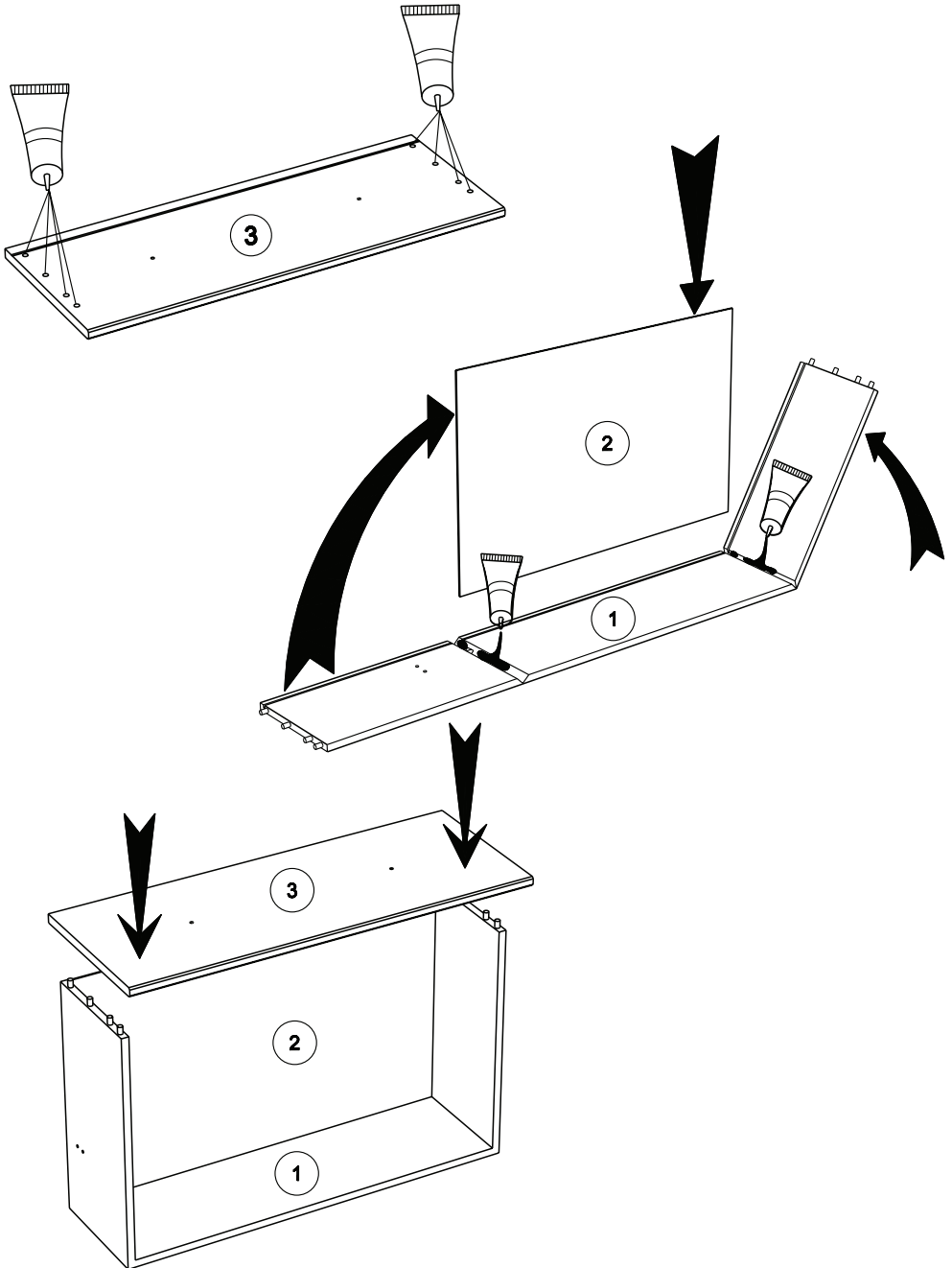

2



AFM x 1



AFN x 1

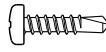

BRL x 4



VJ x 1

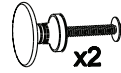

x2



EP x 1

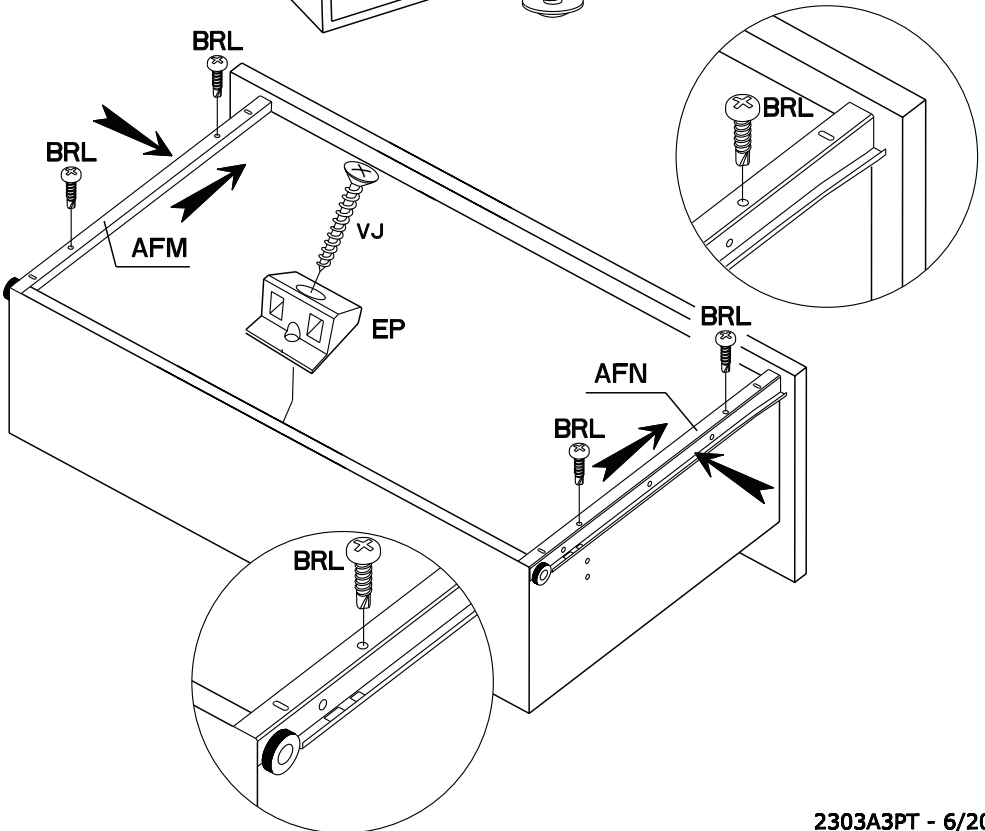
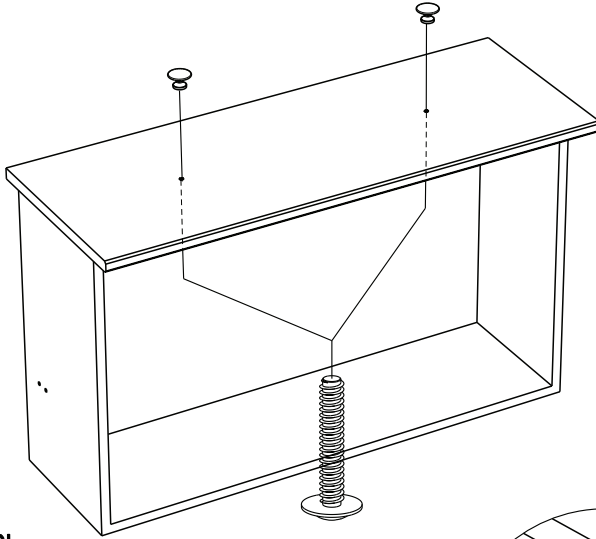

3

CAV x 5

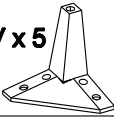

VE x 20



ANK x 5

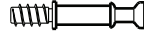

BWC x 6



NZ x 1

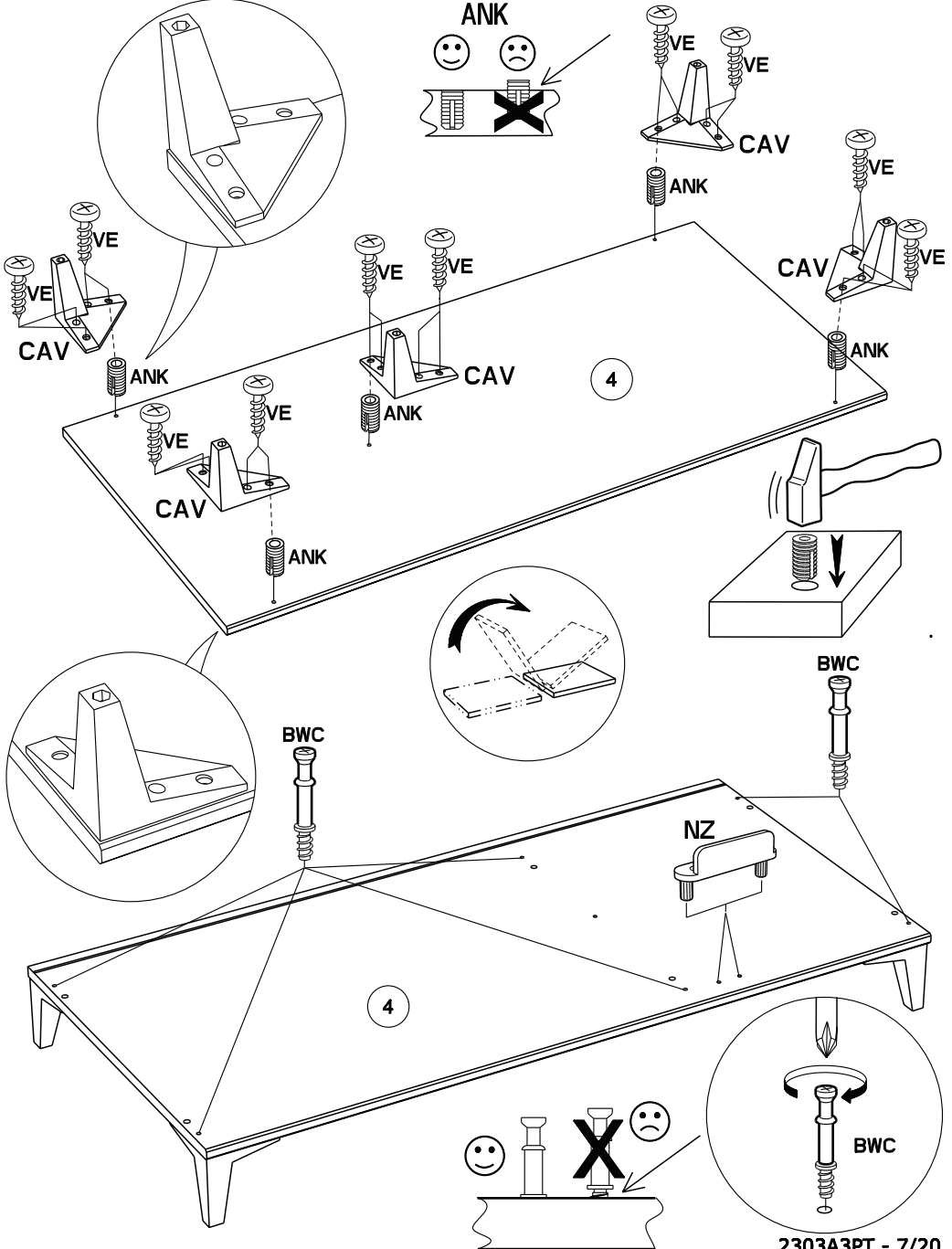

4



ADM x9



BWU x9

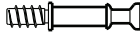

BWC x6



GZ x2



VG x2

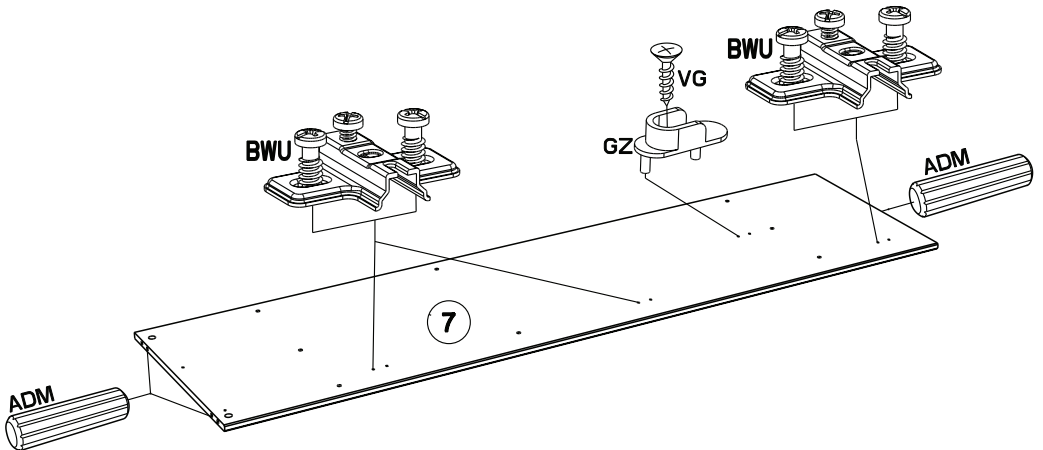
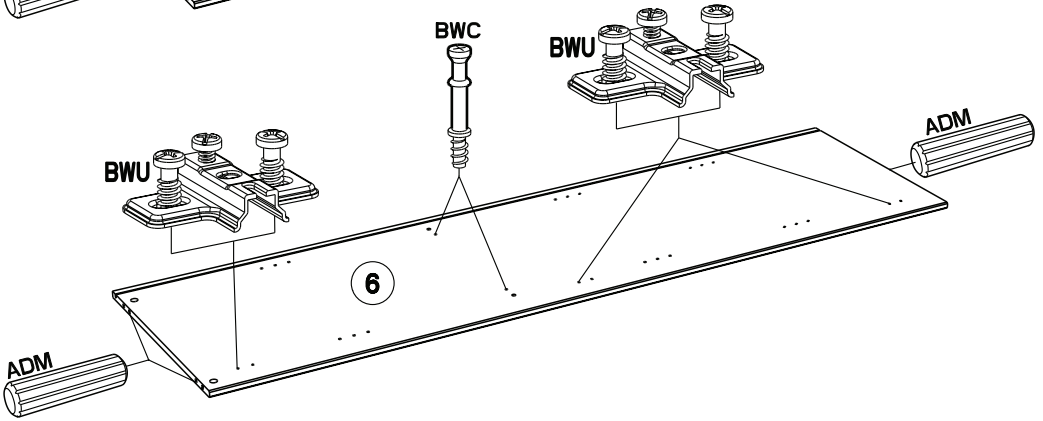
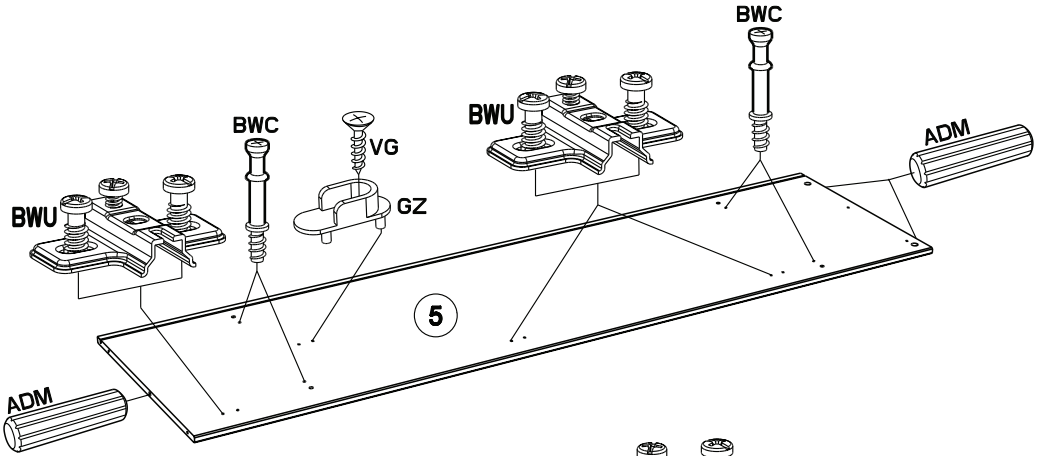

5

ADM x8

NZ x2

BLL x1

VG x1

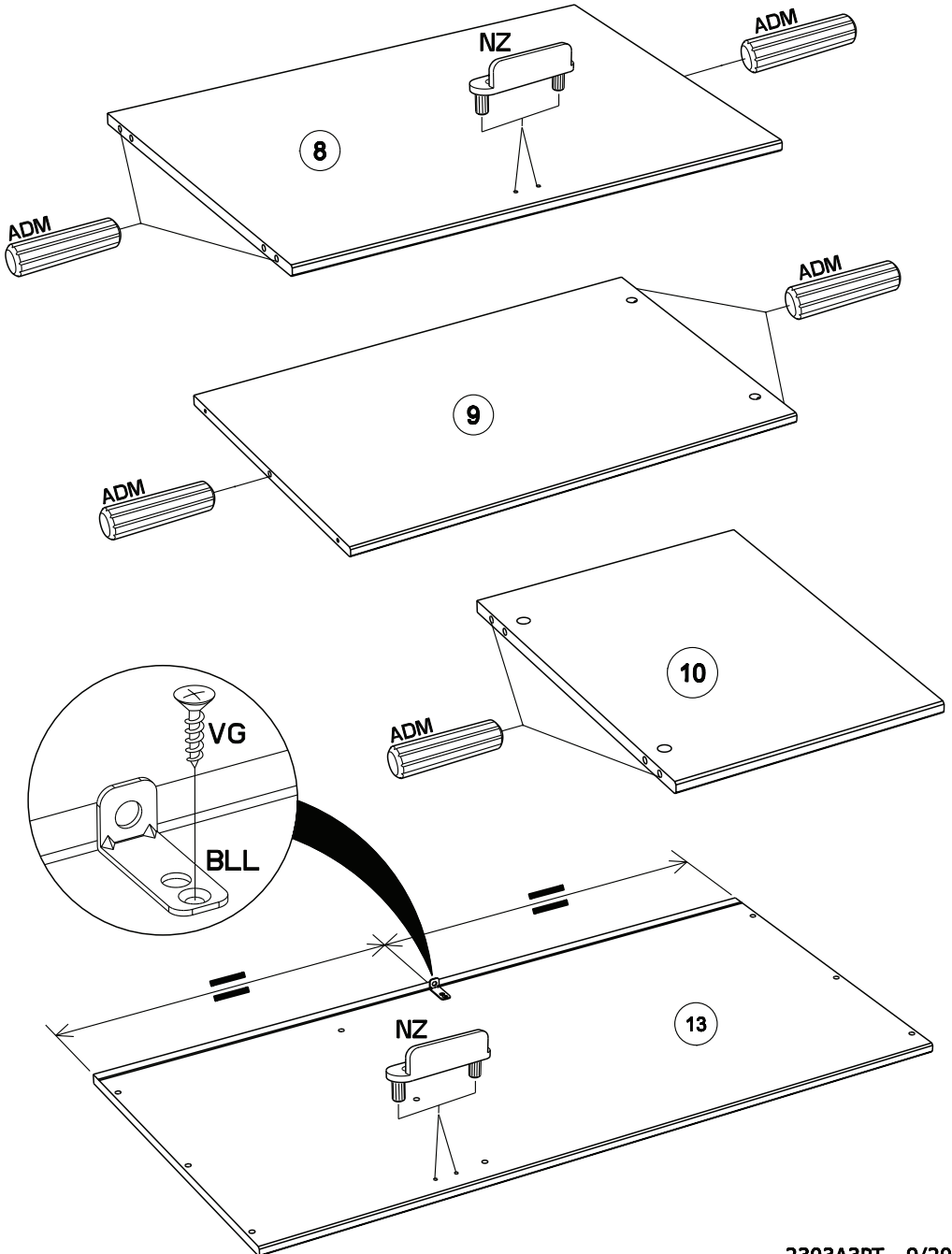

6



Ai x 2



AFK x 1



BWF x 2

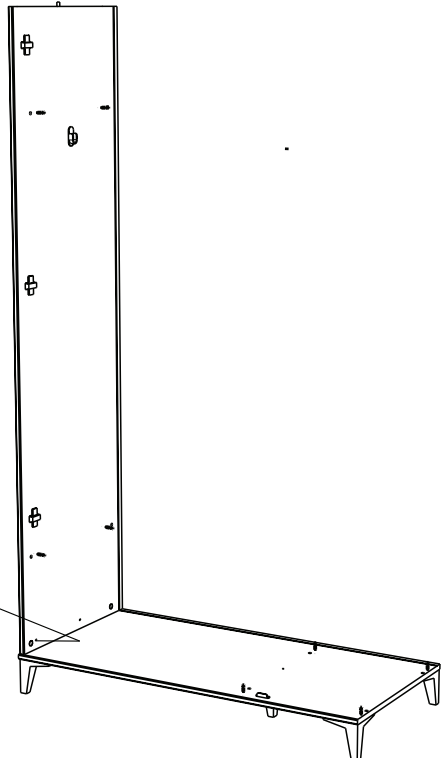
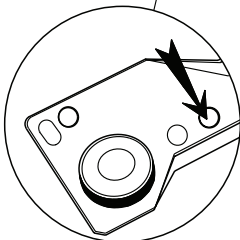
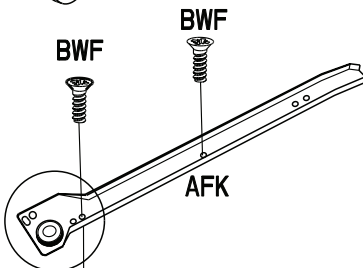
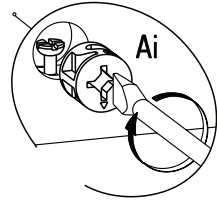
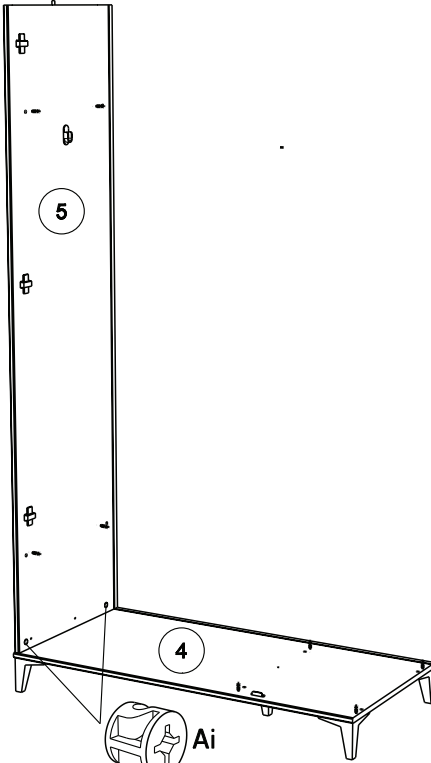

7



HV x1

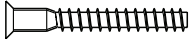

HW x 6



Ai x6

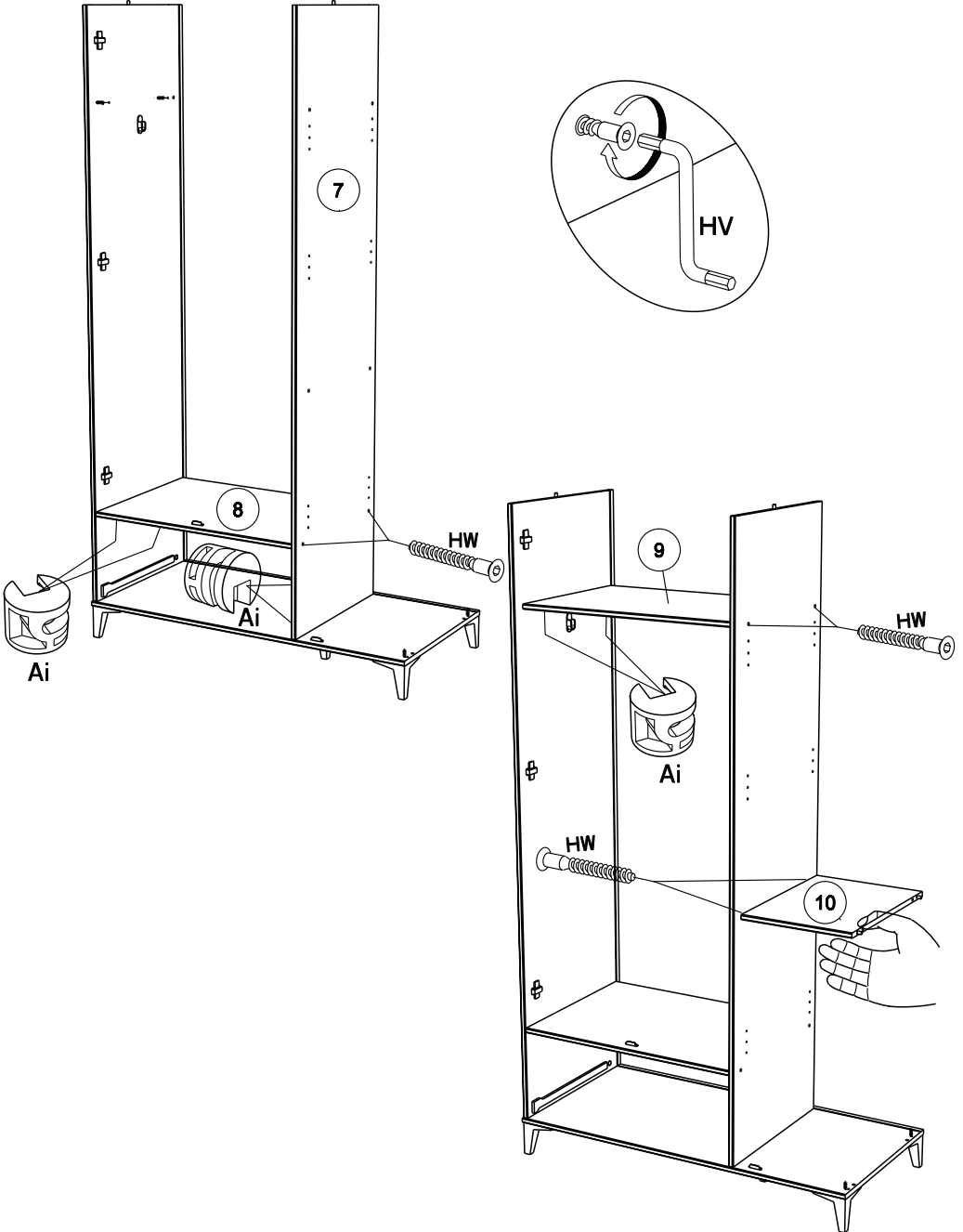

8



AFL x 1



Ai x 4



BWF x 2

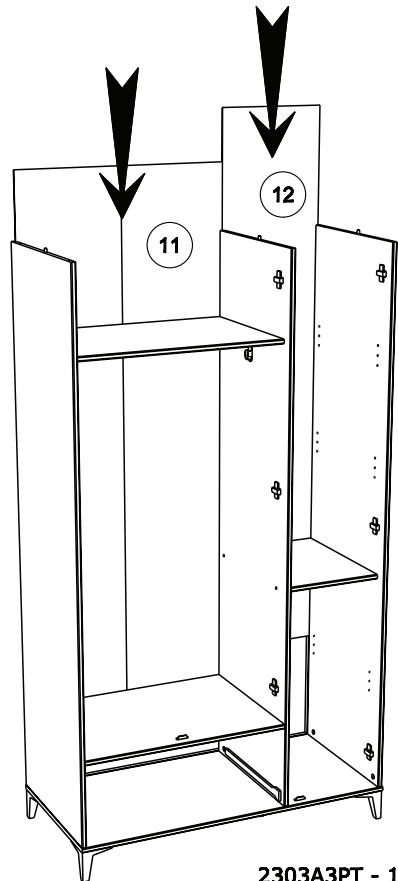
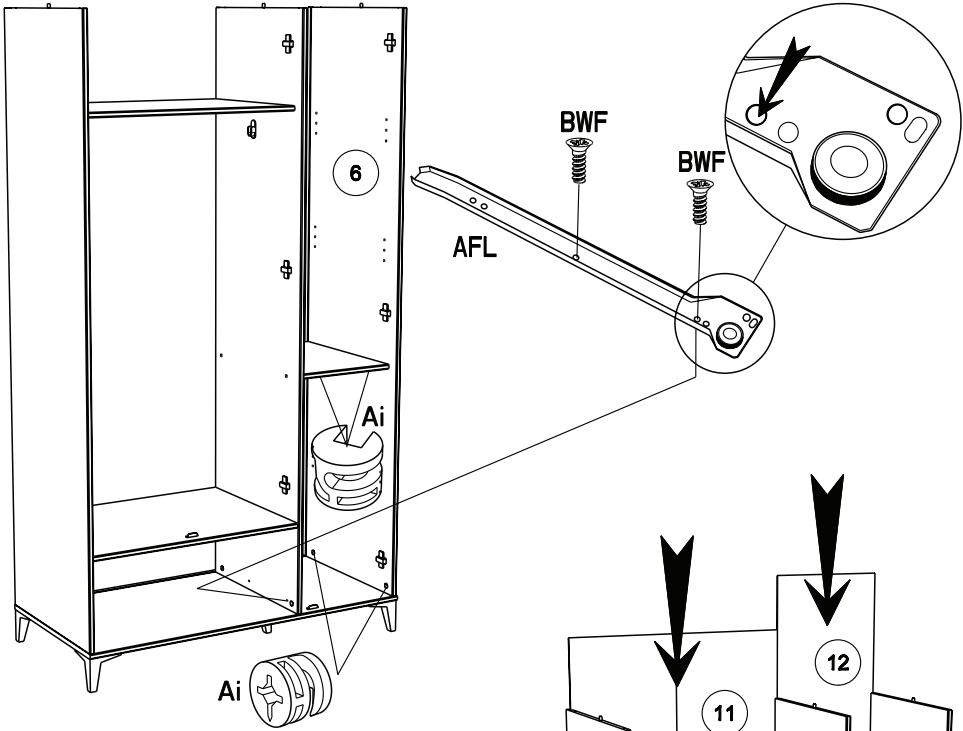

9

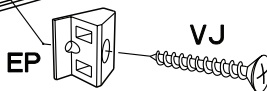
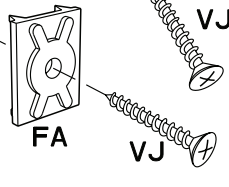
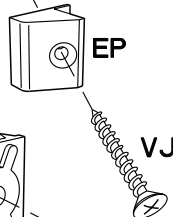
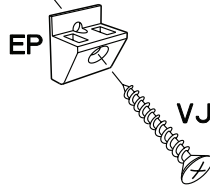
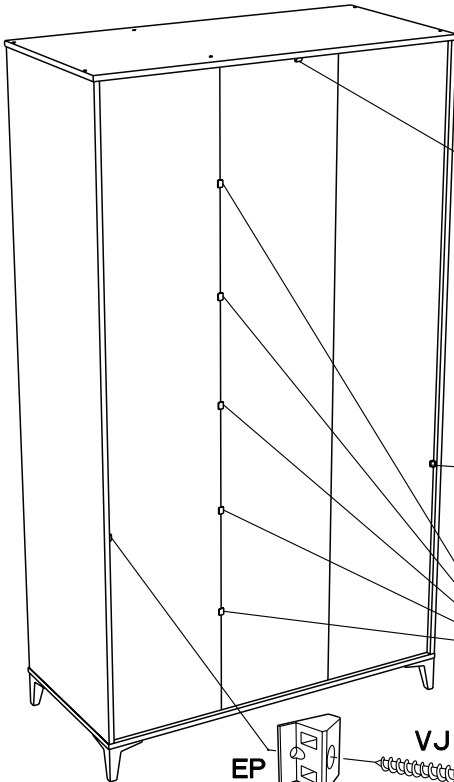
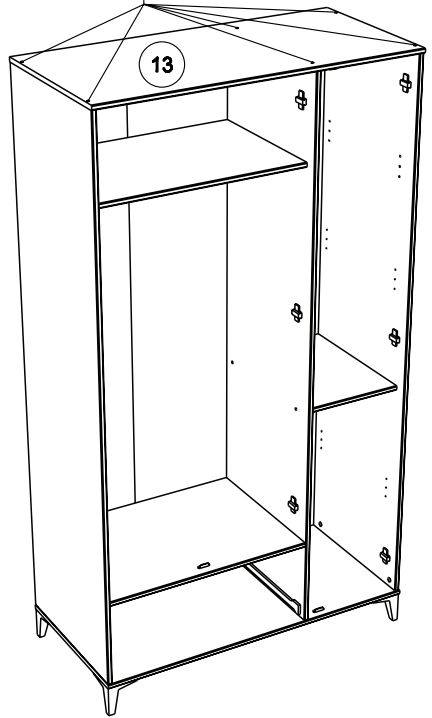
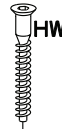
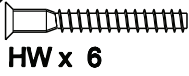

10

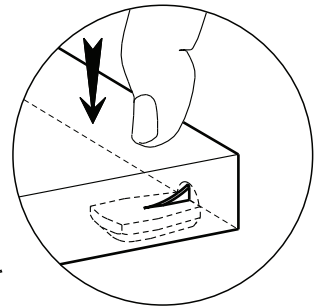
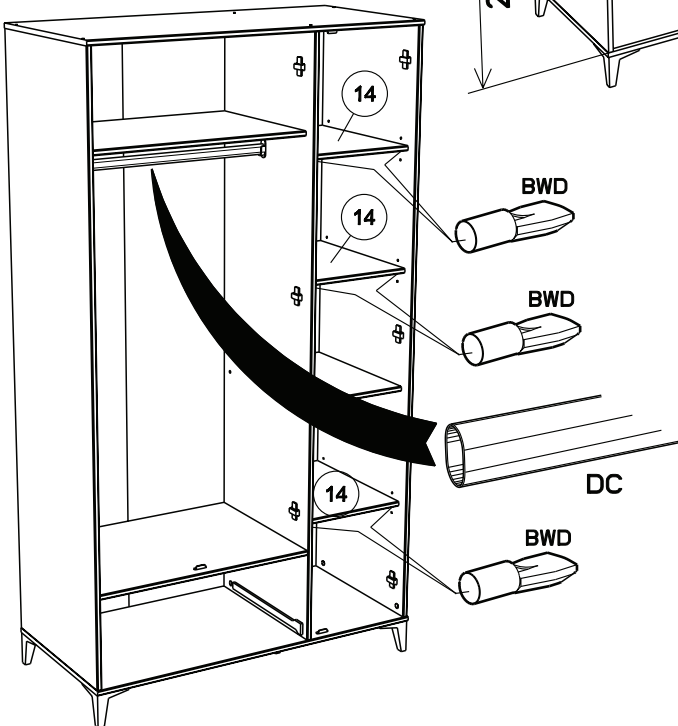
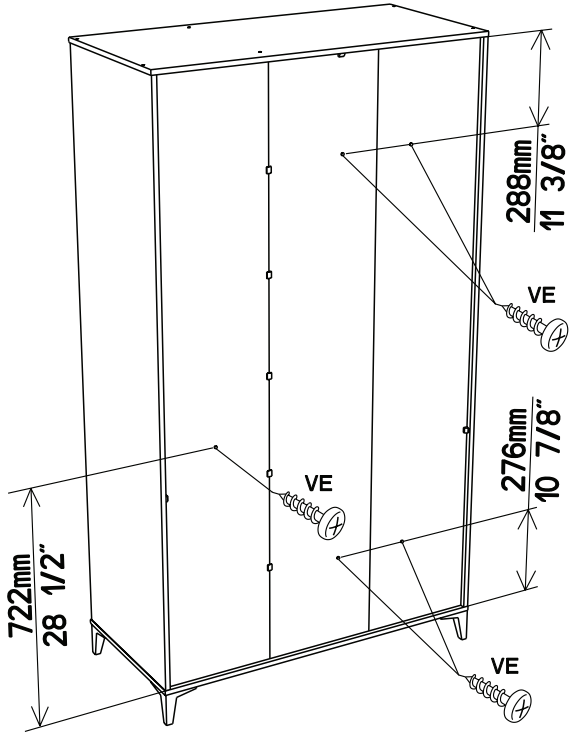
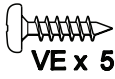

- FR** Pour votre sécurité : Fixation du meuble au mur
Attention, la fixation doit être réalisée par une personne compétente car cela nécessite des chevilles adaptées à la nature de votre mur.
- EN** For your safety: the unit should be secured to the wall.
NB this should be carried out by a competent person as you must use the right rawplug for your type of wall.
- DE** Zu Ihrer Sicherheit: Befestigen Sie das Hochbett an der Wand.
Achtung: Diese Befestigung ist durch eine fachliche kompetente Person vorzunehmen. Hierfür sind für die Bauweise Ihrer Wand geeignete Dübel einzusetzen.
- ES** Por su seguridad: Fijar el mueble a la pared.
Advertencia: la fijación la ha de llevar a cabo por personal adecuado, ya que requiere el uso de tacos que se adapten al tipo de pared.
- PT** Para sua segurança: fixação do móvel ao muro
Atenção: a fixação deverá ser efetuada por pessoa habilitada, visto que são necessárias cavilhas adaptadas ao tipo de parede.
- IT** Avvertenza di sicurezza: il fissaggio del mobile a parete deve essere realizzato da una persona competente, in quanto l'operazione richiede l'impiego di tasselli adatti alla natura del muro.
- NL** Voor uw veiligheid: bevestiging van het meubel aan de muur.
Opgelet de bevestiging moet worden uitgevoerd door een bekwaam persoon daar dit voor uw type muur geschikte pluggen vereist.
- CZ** Z bezpečnostních důvodů: upevněte nábytek do zdi
Pozor, upevnění je třeba svěřit kompetentní osobě, neboť vyžaduje hmoždinky vhodné pro vaši zeď.
- HU** Az Ön biztonsága érdekében : a bútor falra rögzítése
Figyelmeztetés : a rögzítés csak megfelelő szakképesítéssel rendelkező személy által végezhető el, mert a rögzítéshez a fálnak megfelelő csavarokra van szükség.
- PL** Dla bezpieczeństwa: mocowanie mebla do ściany
Uwaga, mocowanie musi zostać wykonane przez osobę kompetentną, ponieważ wymaga to zastosowania kołków dostosowanych do rodzaju ściany.
- RO** Pentru securitatea dumneavoastră: fixarea mobilierului de perete
Atenție, fixarea trebuie să fie realizată de o persoană calificată, deoarece sunt necesare dispozitive de fixare adaptate caracteristicilor peretelui dumneavoastră
- RU** Для вашей безопасности: Крепление мебели к стене
Внимание! Крепление должно производиться опытным специалистом, т.к. для такой установки потребуются штифты, соответствующие типу вашей стены.
- SK** Z bezpečnostných dôvodov: nábytok upevnite k stene.
Dbajte na to, aby upevnenie vykonala kompetentná osoba, pretože pri upevňovaní sa vyžadujú kolíky vhodné do materiálu, z ktorého je stena vyrobená.
- TR** Güvenliğiniz için: Mobilyanın duvara sabitlenmesi
Dikkat, sabitleme işlemi uzman biri tarafından yapılmalıdır çünkü bu işlem için duvarınızın malzemesine uygun dübellerin kullanılması gerekmektedir

اللغة العربية

لسلامتكم الشخصية: تثبيت قطعة الأثاث على الحائط
تحذير، يجب أن يقوم شخص متخصص بعملية التثبيت على الحائط إذ أنها تتطلب اسفينا
معينا يتوافق مع طبيعة الحائط نفسه.

11

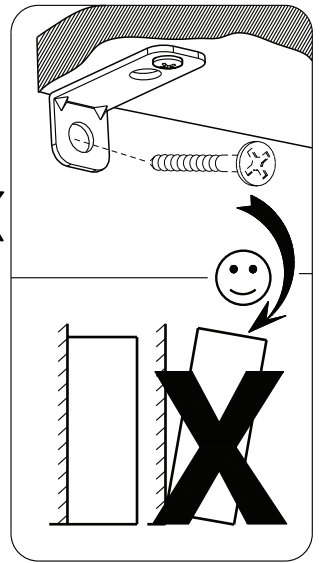
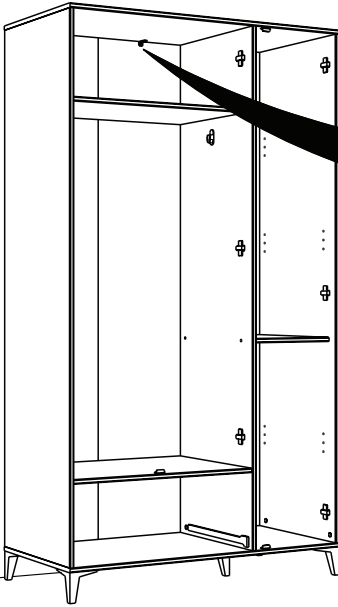

12

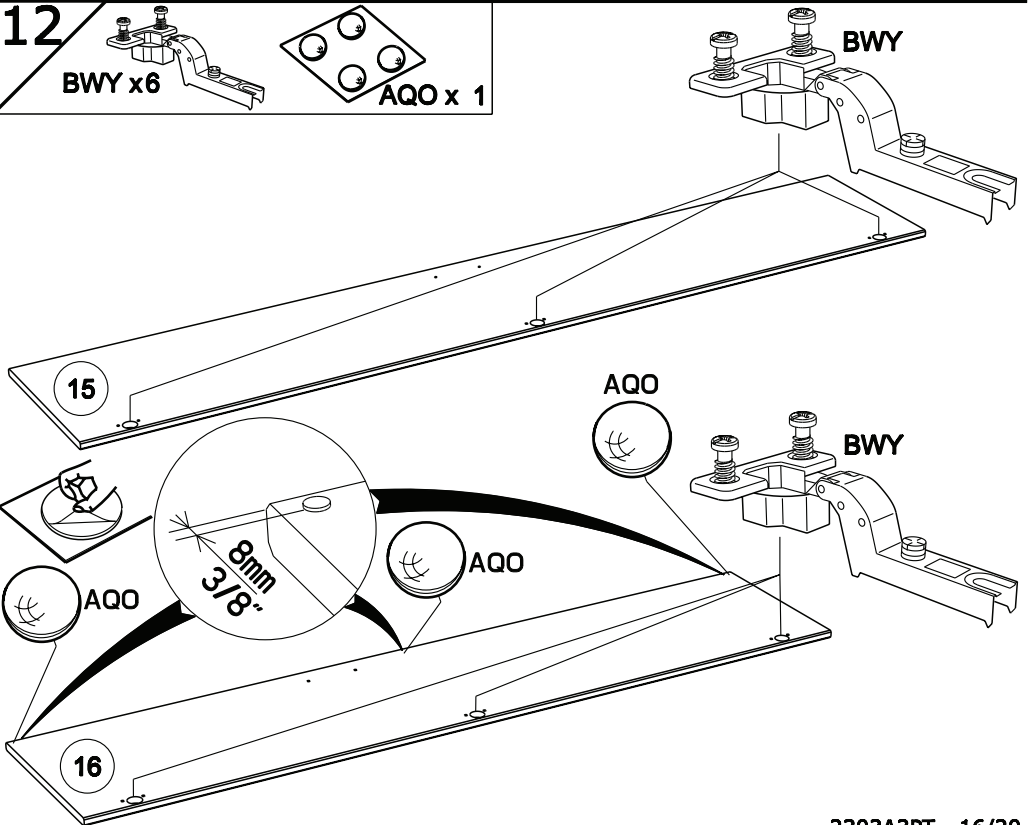
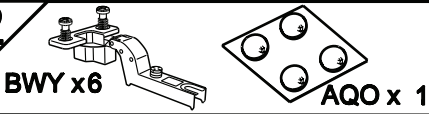

13

BWY x3

AQO x 1



AQO

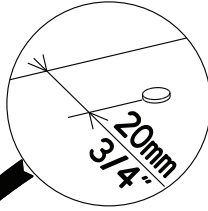

285mm
11 1/4"

17

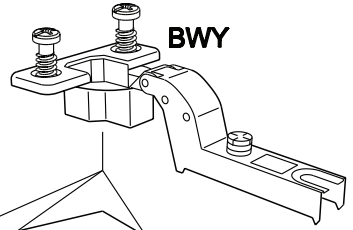

14

17



15



x2



XM x 4

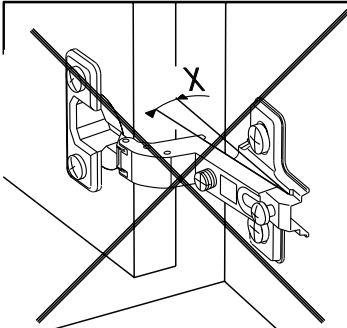
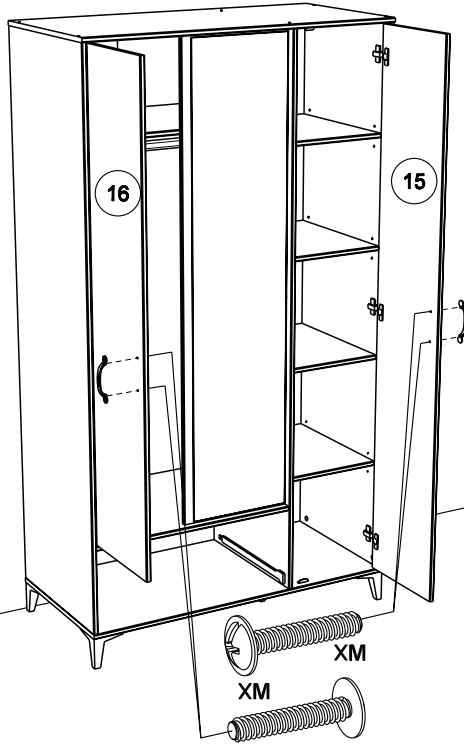

MONTAGE

- Ⓒ GB LEAFLET
- Ⓓ D AUFBAUANLEITUNG
- Ⓔ E MONTAJE
- Ⓕ P MONTAGEM
- Ⓖ I MONTAGGIO
- Ⓗ NL MONTAGE

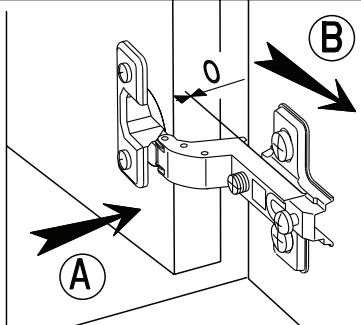

REGLAGE

- Ⓒ GB ADJUSTING
- Ⓓ D ANPASSUNG
- Ⓔ E AJUSTER
- Ⓕ P REGULACAO
- Ⓖ I AGGIUSTAMENTO
- Ⓗ NL AFSTELLING

A

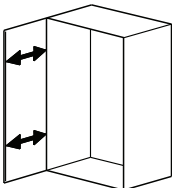

B

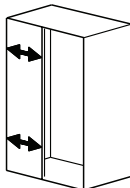

C

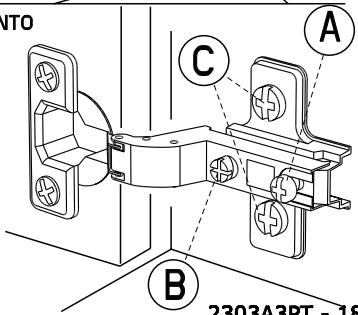
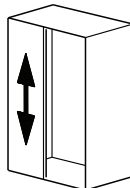

16

CAX x9

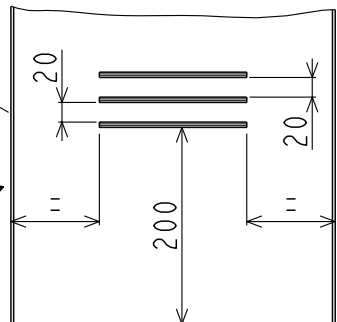
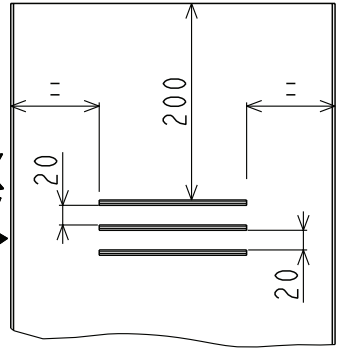
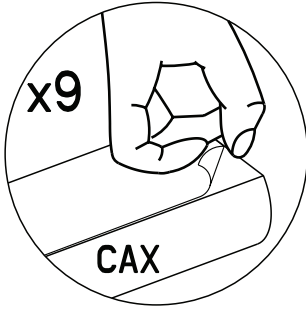

17

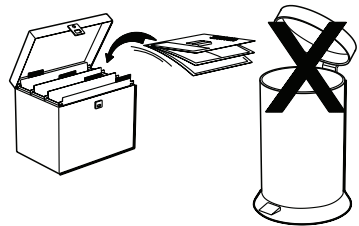

Faites un geste pour l'environnement en triant vos déchets d'emballage
Make a gesture for the environment by sorting out your waste of packaging
Machen Sie eine Bewegung für die Umwelt, ihre Verpackungsabfälle sortierend
Haga un gesto para el medio ambiente escogiendo sus residuos de embalaje